

The Chamberlain Group, Inc.
A DUCHOSSOIS ENTERPRISE
845 Larch Avenue
Elmhurst, Illinois 60126-1196

Complies with UL 325
regulations effective
January 1, 1993



CHAMBERLAIN[®] **SECURITY[™]+**

Garage Door Opener
Models 4640, 4640-2, & 4640-2K
1/2 HP

For Residential Use Only

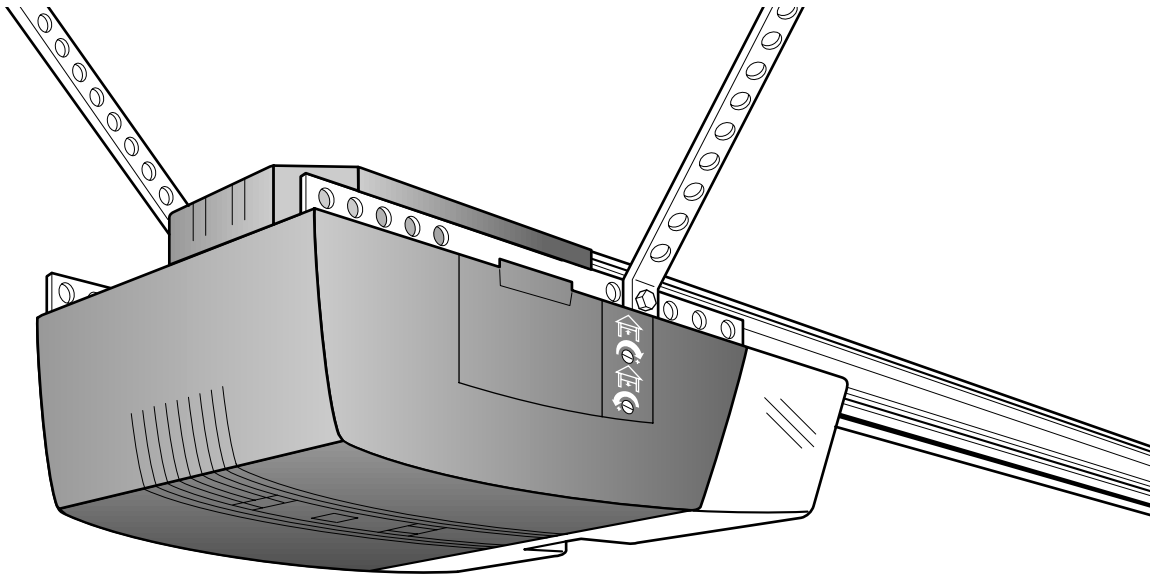

Owner's Manual

- Please read this manual and the enclosed safety materials carefully!
- Fasten the manual near the garage door after installation.
- The door **WILL NOT CLOSE** unless the Protector System[®] is connected and properly aligned.
- Periodic checks of the opener are required to ensure safe operation.
- The model number label is located on the back of your opener.

Contents

<p>Safety alert symbol review.....2</p> <p>Safety information, precautions, tools3</p> <p>Testing your garage door for binding & balance3</p> <p>Carton inventory4</p> <p>Hardware inventory5</p> <p>Illustration of sectional door installation6</p> <p>Illustration of one-piece door installation7</p> <p>Assembly section - pages 8 – 11</p> <p>Assemble the rail8</p> <p>Fasten rail to power unit.....10</p> <p>Install the trolley10</p> <p>Attach the rail brackets11</p> <p>Installation section - pages 12 – 27</p> <p>Installation safety instructions11</p> <p>Determine the header bracket location</p> <p> Sectional door12</p> <p> One-piece door.....13</p> <p>Install the header bracket14</p> <p>Attach the rail to the header bracket15</p> <p>The Protector System®</p> <p> safety reversing sensor information16</p> <p>Install the safety reversing sensor17</p> <p>Position the opener.....19</p> <p>Hang the opener20</p> <p>Install the door control and connect all wires21</p> <p>Electrical requirements22</p>	<p>Complete the safety reversing sensor installation.....22</p> <p>Install the lights and lens23</p> <p>Attach the manual release rope and handle.....23</p> <p>Fasten the door bracket (sectional door)24</p> <p>Fasten the door bracket (one-piece door).....25</p> <p>Connect door arm to trolley (sectional door)26</p> <p>Connect door arm to trolley (one-piece door).....27</p> <p>Adjustment section - pages 28 – 30</p> <p>Travel limit adjustments.....28</p> <p>Force adjustments29</p> <p>Test the Protector System®30</p> <p>Test the safety reverse system30</p> <p>Operation safety instructions31</p> <p>Care of your opener31</p> <p>Maintenance schedule.....31</p> <p>Operation of your opener.....32</p> <p>Receiver & remote control programming33</p> <p>Having a problem?34</p> <p>Repair parts, rail assembly36</p> <p>Repair parts, installation36</p> <p>Repair parts, power unit37</p> <p>Accessories38</p> <p>Index39</p> <p>How to order repair parts40</p> <p>Warranty.....40</p>
---	--

Start by reviewing these important safety alert symbols:

When you see these Safety Symbols on the following pages, they will alert you to the possibility of *serious injury or death* if you do not comply with the corresponding instructions. The hazard may come from something mechanical or from electric shock. *Read the instructions carefully.*



WARNING

Mechanical



WARNING

Electrical

When you see this Safety Symbol on the following pages, it will alert you to the possibility of damage to your garage door and/or the garage door opener if you do not comply with the corresponding instructions. *Read the instructions carefully.*



CAUTION

This garage door opener is designed and tested to offer safe service provided it is installed, operated, maintained and tested in strict accordance with the safety instructions contained in this manual.

Safety Information, Precautions, Tools



WARNING

An unbalanced garage door might not reverse when required and someone under the door could be seriously injured or killed.

If your garage door binds, sticks or is out of balance, call for professional garage door service. *Garage doors, door springs, cables, pulleys, brackets, and their hardware are under extreme tension and can cause serious injury or death.* Do not try to loosen, move or adjust them yourself!

Ropes left on a garage door could cause someone to become entangled and killed. Remove all ropes connected to the door before installing and operating the opener.



CAUTION

To avoid damage to the garage door and opener, disable locks before installing and operating the opener. Use a wood screw or nail to hold locks in the "open" (unlocked) position.

Operation at other than 120V 60 Hz will cause opener malfunction and damage.

Identify the type and height of your door, any special conditions that exist, and any additional materials that may be required. Refer to pages 6 and 7.

Test Your Door for Balance

Before you begin, complete the following test to make sure your door is balanced, and is not sticking or binding:

- Lift the door about halfway as shown. Release the door. It should stay in place, supported entirely by its springs.
- Raise and lower the door to see if there is any binding or sticking.

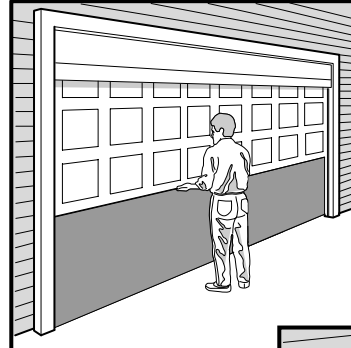

Sectional Door

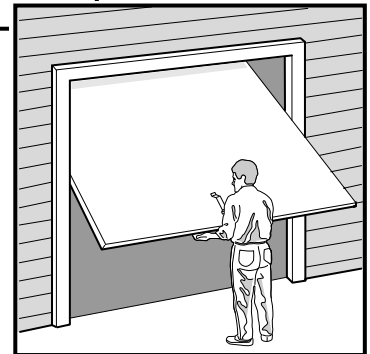

One-Piece Door

During assembly, installation and adjustment of the opener, instructions will call for tools shown below.

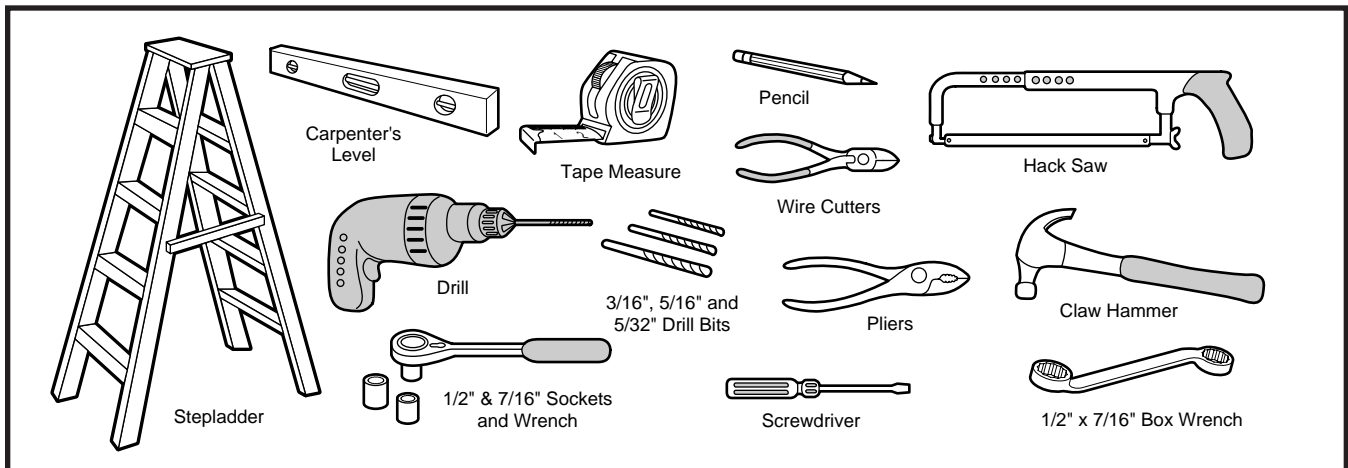

Carton Inventory

Your garage door opener is packaged in one carton which contains the power unit and parts illustrated below. Accessories will depend on model purchased. If anything is missing, carefully check the packing material. Parts may be "stuck" in the foam. **KEEP THE FOAM INTACT** (see page 10). Hardware for assembly and installation is shown on page 5.

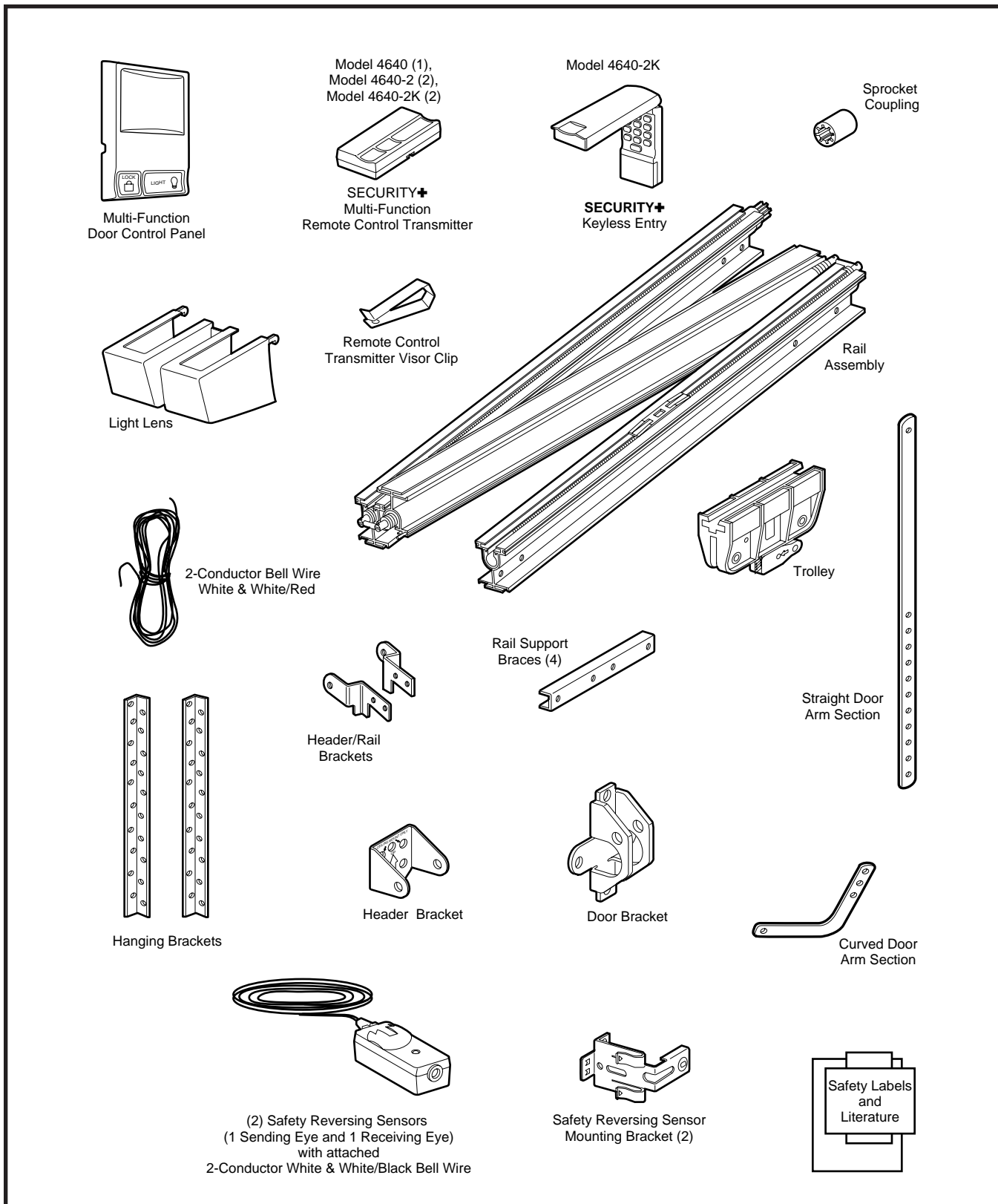

Hardware

Separate all hardware from the packages in the rail carton and the opener carton and group as shown below, for the assembly and installation procedures.

Assembly Hardware

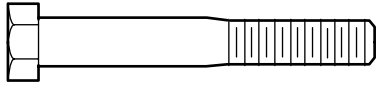

Bolt
1/4-20x1-3/4" (8)

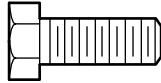

1/4" - 20 x 5/8"
Hex Screw (4)

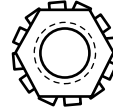

Lock Nut
1/4"-20 x 7/16 (12)

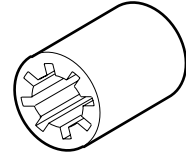

Sprocket Coupling Sleeve

Installation Hardware

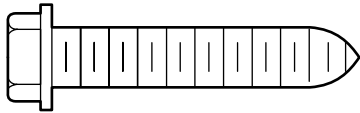

Lag Screw
5/16"-9x1-5/8" (2)

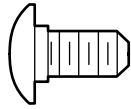

Carriage Bolt
1/4"-20x1/2" (2)



Wing Nut (2)

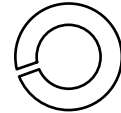

Lock Washer 5/16" (6)



Lag Screw
5/16"-18x1-7/8" (2)

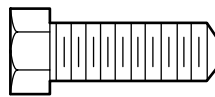

Hex Screw
5/16"-18x7/8" (4)

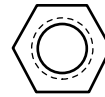

Nut 5/16"-18 (6)

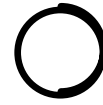

Ring Fastener (3)



Rope

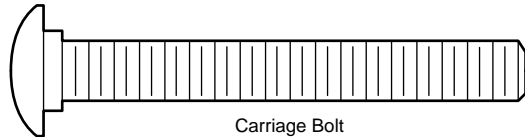

Carriage Bolt
5/16"-18x2-1/2" (2)



Handle

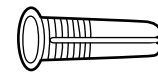

Dry Wall Anchors (2)



Screw
6ABx1-1/4" (2)



Screw 6-32x1" (2)

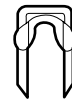

Insulated
Staples (30)

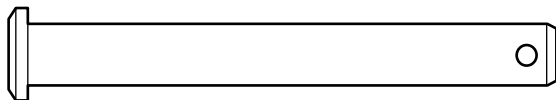

Clevis Pin
5/16"x2-3/4" (1)

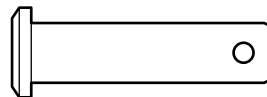

Clevis Pin
5/16"x1-1/4" (1)

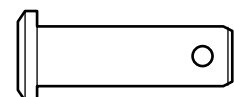

Clevis Pin
5/16"x1" (1)

SECTIONAL Door Installation

Before you begin, survey your garage area to see whether any of the conditions below apply to your installation. You may find it helpful to refer back to this page as you proceed with the installation of your opener.

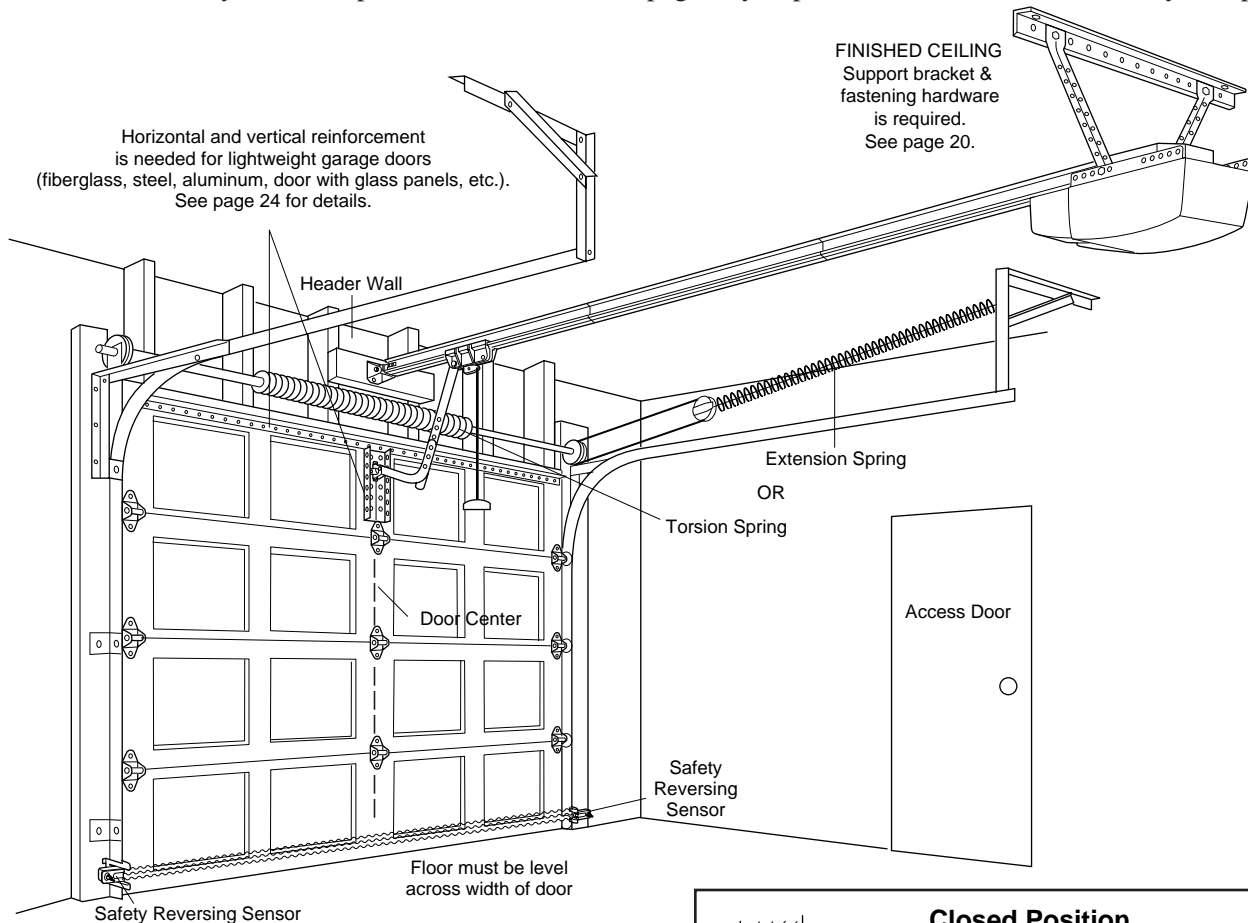

Based on your particular requirements, there are several installation steps which might call for materials and/or hardware not included in the carton.

- Step 1, page 12 – Look at the wall or ceiling above the garage door. The header bracket *must* be securely fastened to structural supports.
- Safety reversing sensor, page 16 – Depending upon garage construction, extension brackets (see Accessories) or wood blocks may be needed to fasten sensors to mounting locations.
- Step 4, page 17 – Floor mounting of the safety reversing sensor will require hardware not provided.
- Step 6, page 20 – Do you have a finished ceiling in your garage? If so, a support bracket and additional fastening hardware may be required.
- Step 12, page 24 – Do you have a steel, aluminum, fiberglass or glass panel door? If so, horizontal and vertical reinforcement is required.
- Look at the garage door where it meets the floor. **It must close on the floor all the way across. Otherwise, the safety reverse system may not work properly.** See page 30. Floor or door should be repaired.

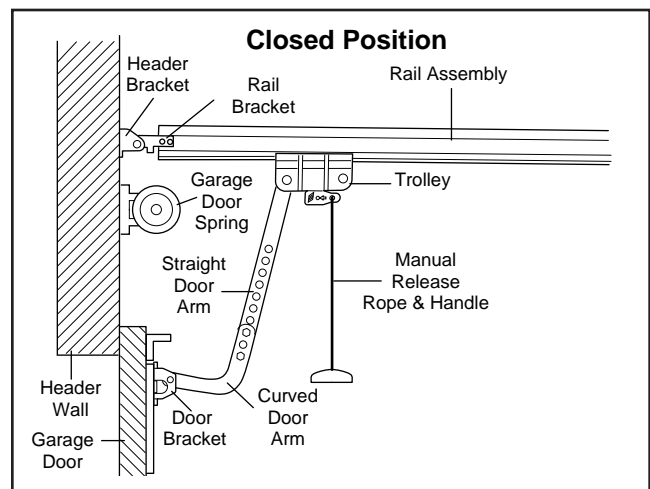

- The opener can be installed within 4 feet of the left or right of the door center if there is a torsion spring or center bearing plate in the way of the header bracket or door bracket area. *If your door has extension springs, the opener must be installed in the center of the door.* See pages 12 and 24.
- Do you have an access door in addition to the garage door? If not, Model 7702CB Outside Quick Release is required. See page 38.
- If your door is more than 7 feet high, see the rail extension kits listed on page 38.

ONE-PIECE Door Installation

Before you begin, survey your garage area to see whether any of the conditions below apply to your installation. You may find it helpful to refer back to this page as you proceed with the installation of your opener.

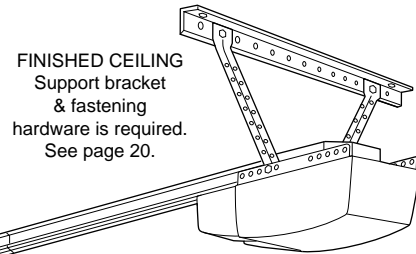

One-Piece Door without Track

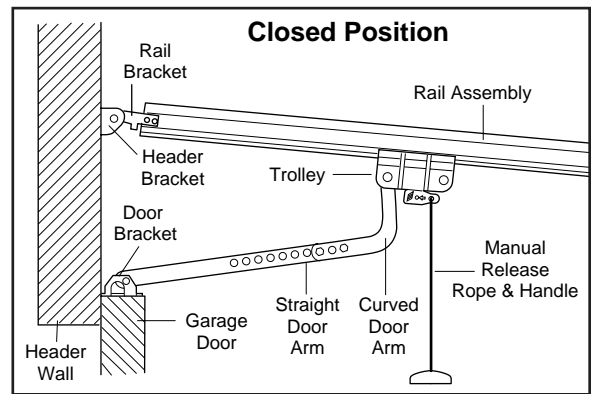
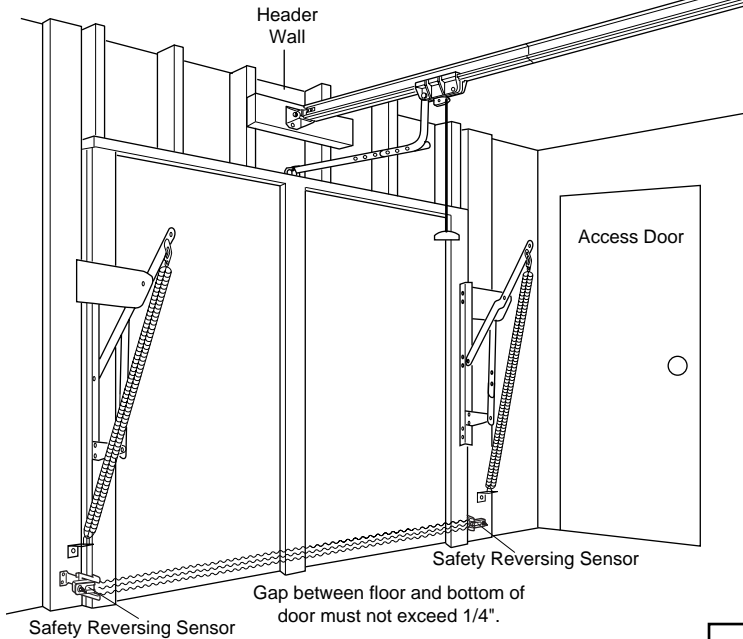

Based on your particular requirements, there are several installation steps which might call for materials and/or hardware not included in the carton.

- Step 1, page 13 – Look at the wall or ceiling above the garage door. The header bracket *must* be securely fastened to structural supports.
- Step 6, page 20 – Do you have a finished ceiling in your garage? If so, a support bracket and additional fastening hardware (not supplied) may be required.
- Safety reversing sensor, page 16 – Depending on garage construction, extension brackets (see Accessories) or wood blocks may be needed to fasten sensors to mounting locations.
- Step 14, page 17 – Floor mounting of the safety reversing sensor will require hardware that is not provided.
- Step 12, page 25 – Generally, a one-piece door does not require reinforcement. If your door is lightweight, you can refer to the information relating to sectional doors on page 24.
- Step 12, page 25 – Depending on your door's construction, you might need additional mounting hardware for the door bracket.
- Do you have an access door in addition to the garage door? If not, Model 7702CB Outside Quick Release is required. See page 38.
- **The gap between the bottom of the garage door and the floor cannot exceed 1/4". Otherwise, the safety reverse system may not work properly.** See page 30. The floor or the door should be repaired.

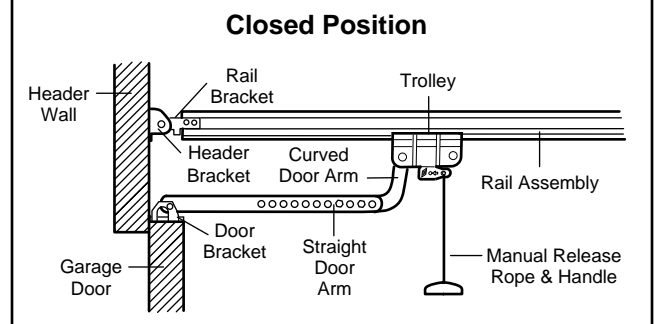
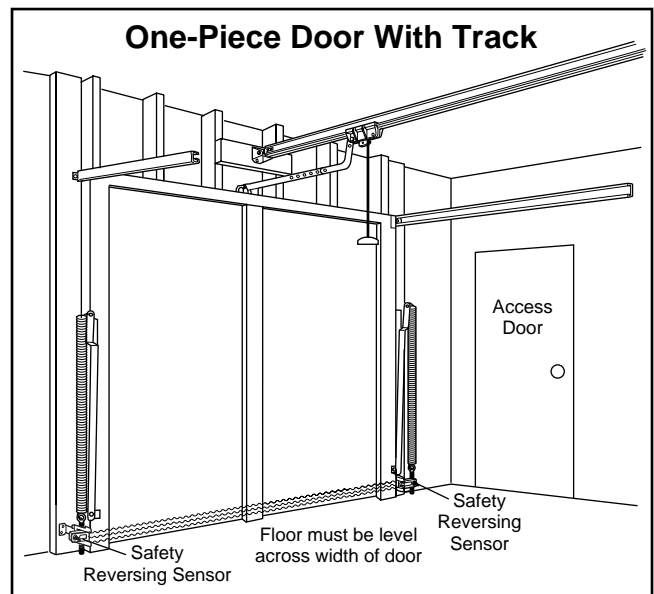

ASSEMBLY STEP 1 Assemble the Rail

To avoid installation difficulties, do not run the garage door opener until instructed to do so.

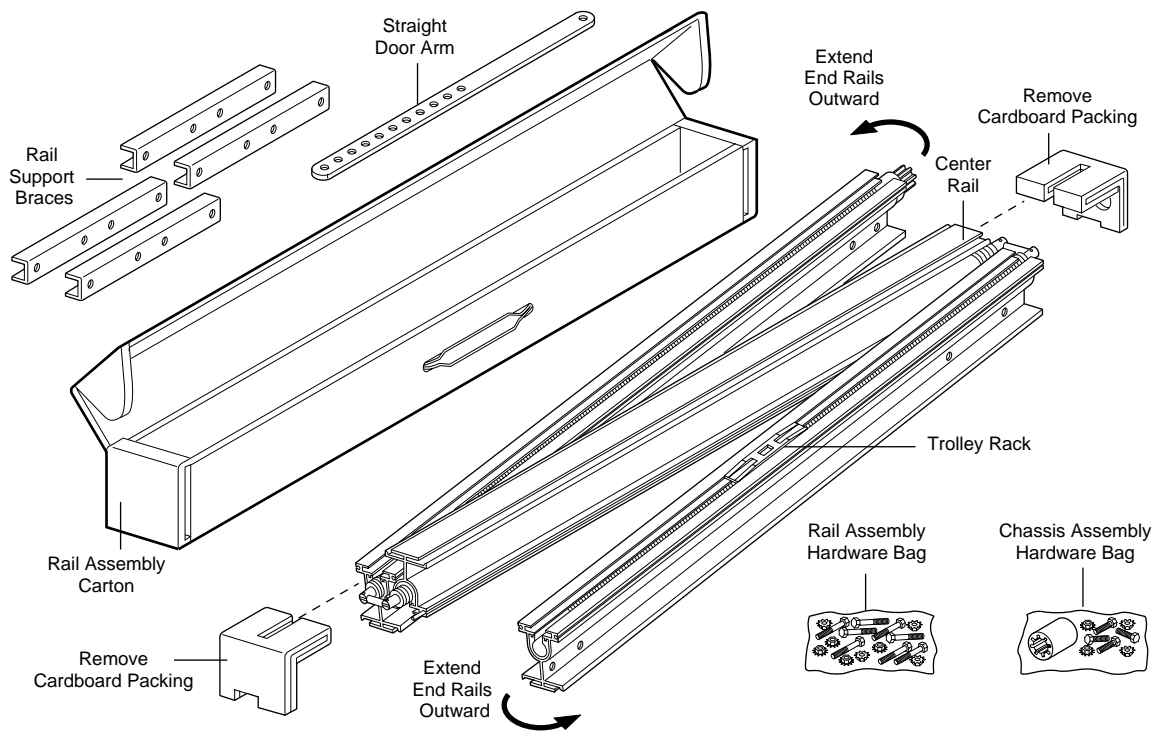

1. Turn the opened rail carton upside down, emptying its contents onto a level work surface.
2. Unfold the rails, taking care to avoid kinking the screw rod joints.
3. Rotate the rail sections so that the flat side is down and the screw side is up for all three lengths. Keep it clean and free of debris while you are working.

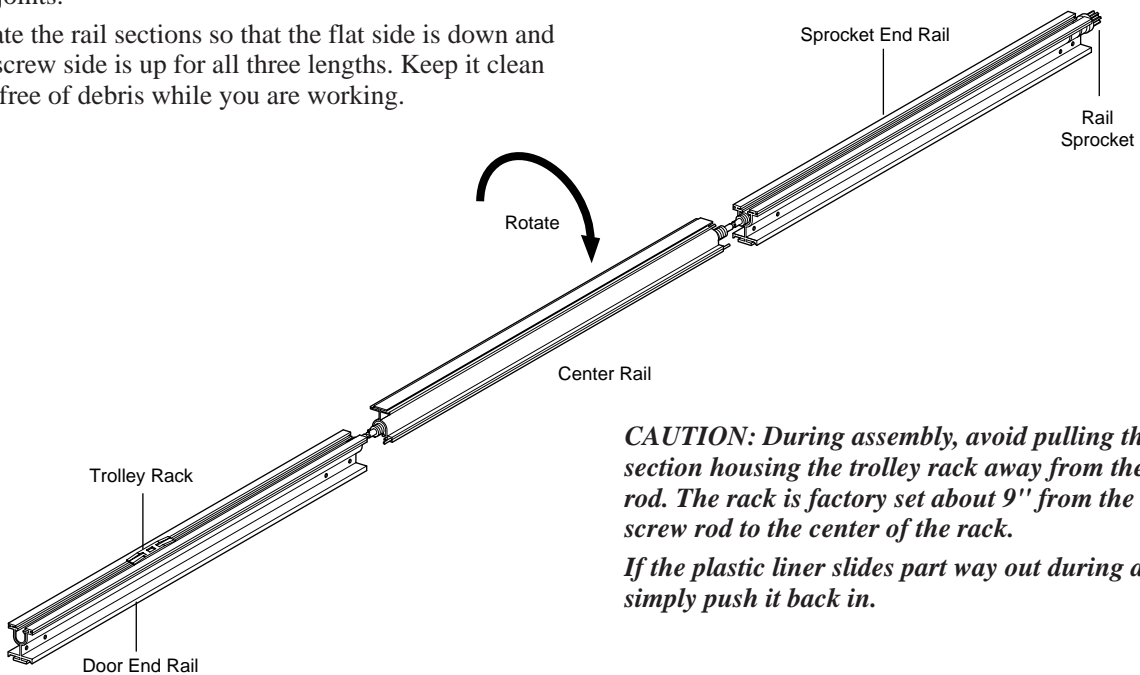

CAUTION: During assembly, avoid pulling the rail section housing the trolley rack away from the screw rod. The rack is factory set about 9" from the end of the screw rod to the center of the rack.

If the plastic liner slides part way out during assembly, simply push it back in.

ASSEMBLY STEP 1 (Continued)

Assemble the Rail

- Beginning with the sprocket end, straighten the two rail sections so that the screw rod is in a straight line at the joint. (Avoid handling the joints, which may have sharp edges.)
- Carefully slide the pins at the top edge of the rail into the openings on the adjacent rail. ***It is essential that the rail assembly be on a level surface to achieve proper alignment and to avoid damage to the pins.***
- Insert two 1/4"-20x1-3/4" bolts through the *center* holes of a brace, and place its *open* length against the rail at this joint, aligning the holes as shown. Position another brace on the opposite side of the rail over the bolts, add 1/4"-20 lock nuts, and hand tighten. Insert two additional bolts and hand tighten.
- Keeping the rail straight and on a level surface, grasp the screw rods on each side of the remaining joint and pivot into a straight line. Repeat steps 5 and 6.
- With a 7/16 wrench, tighten bolts til snug, working from the center holes of the braces to those further from the joints. Do not overtighten.

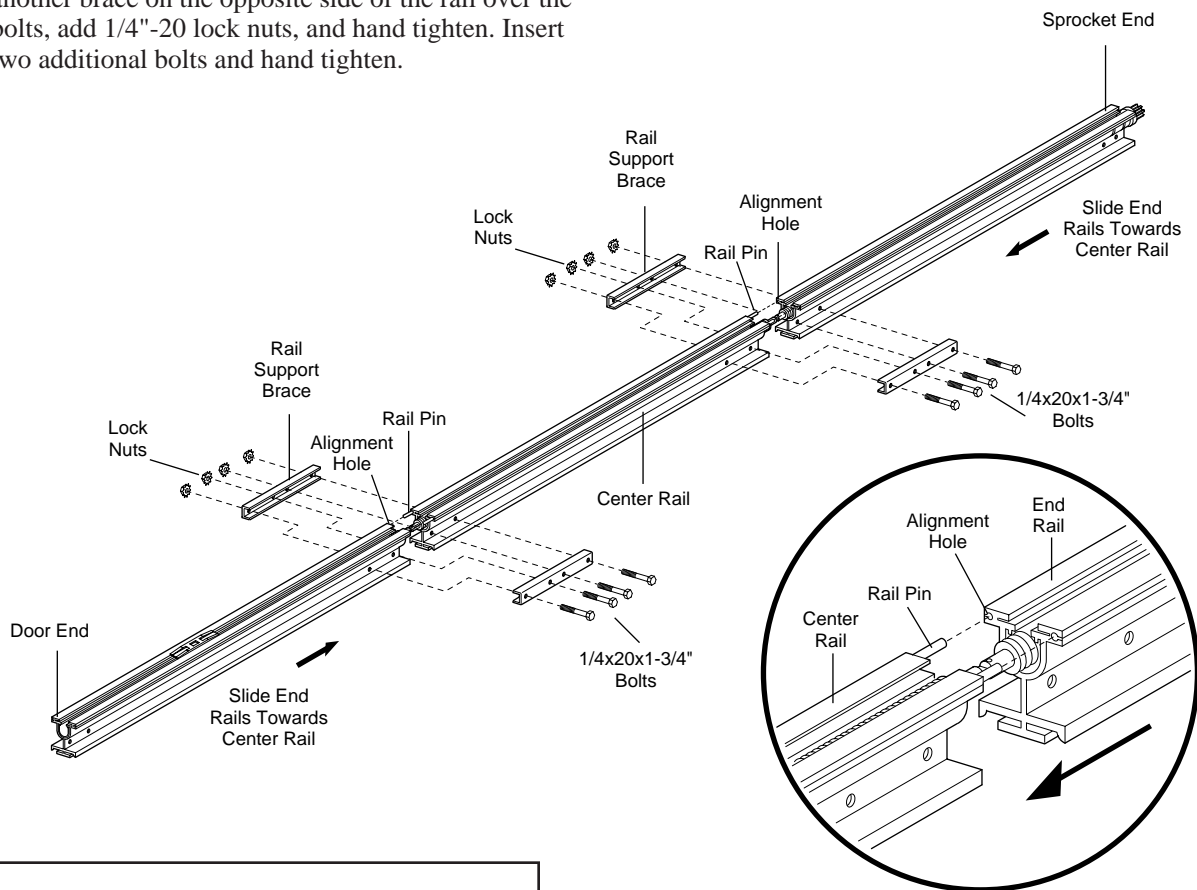

Hardware Shown Actual Size

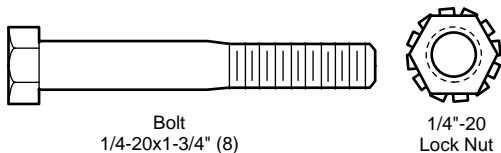

ASSEMBLY STEP 2

Fasten the Rail To the Power Unit and Install the Trolley

NOTE: To aid in assembly and installation, replace the foam packing around the power unit. Remove it after Installation Step 5.

- Working on a level surface, align the rail assembly with the power unit, as shown.
- Slip the coupling over the rail sprocket.
- Slide the rail through the power unit bracket until the coupling fits securely over the power unit sprocket.
- Align the two screw holes in the rail with those in the power unit bracket. Insert two 1/4"-20x5/8" hex screws and lock nuts. Tighten securely with a 7/16" socket wrench.

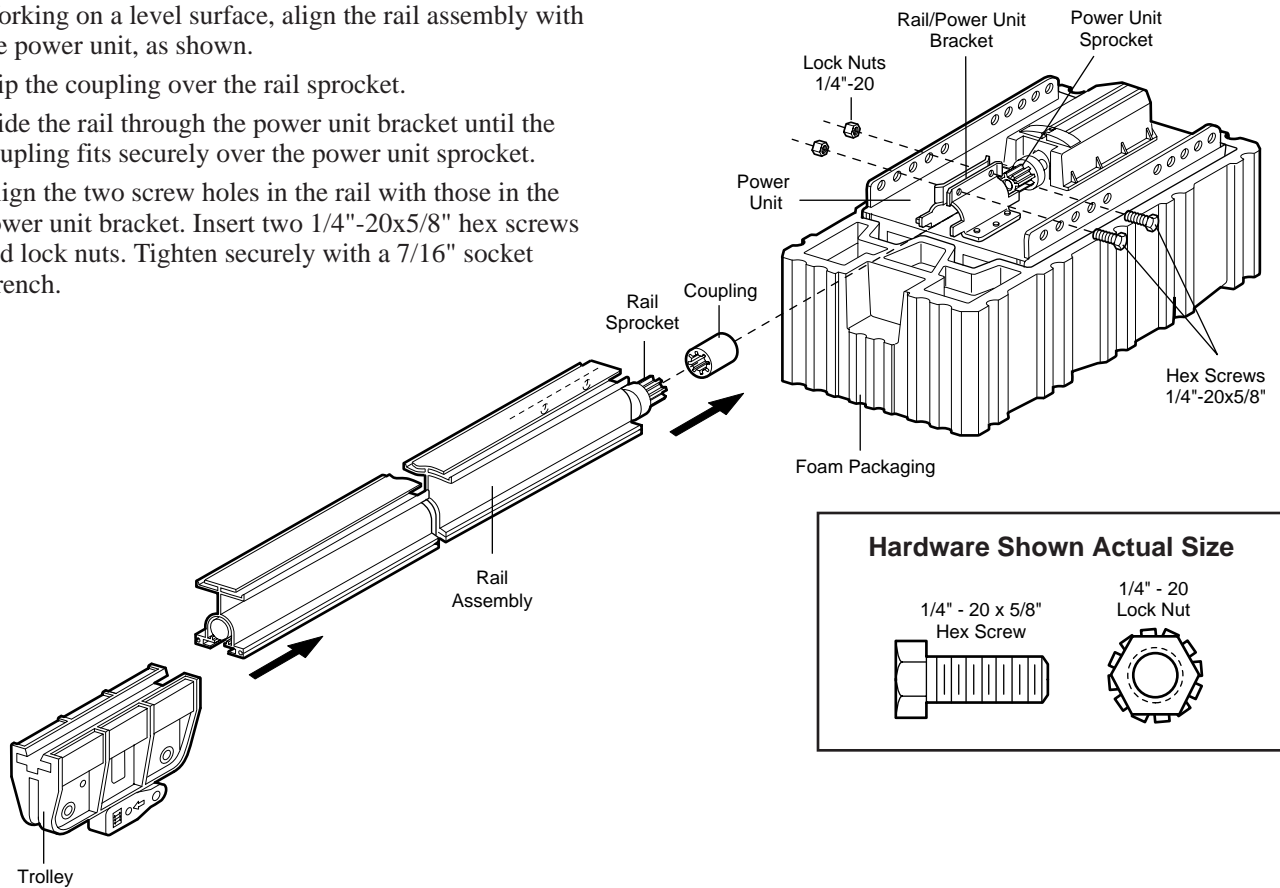

As illustrated above, slide the trolley onto and along the bottom of the rail until it snaps firmly in place. ***Be certain to install it facing correctly: the trolley release arm must be horizontal (lock position), with its arrow pointed away from the power unit.***

ASSEMBLY STEP 3

Attach the Rail Brackets

- Align rail brackets to end of rail assembly, as shown.
- Insert two 1/4"-20 x 5/8" hex screws and lock nuts. Tighten securely with a 7/16" socket.

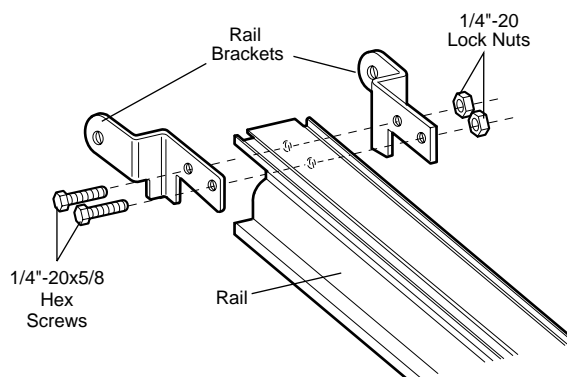
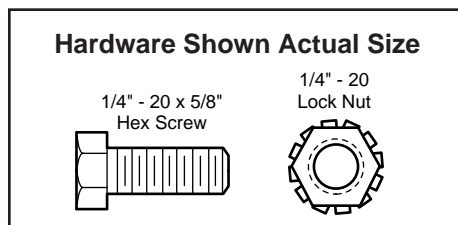

You have now finished assembling your garage door opener. Please read the following warnings before proceeding to the installation section:

IMPORTANT INSTALLATION INSTRUCTIONS



WARNING



WARNING

To reduce the risk of severe injury or death to persons:

1. **READ AND FOLLOW ALL INSTALLATION INSTRUCTIONS**
2. Install only on a properly balanced and lubricated garage door. *An improperly balanced door may not reverse and could result in severe injury or death.* Repairs to cables, spring assemblies and other hardware must be made by a professional service person before installing opener.
3. Disable all locks and remove all ropes connected to the garage door before installing the opener. *Ropes connected to a garage door can cause entanglement and death.*
4. If possible, install door opener 7 feet or more above floor with the manual release handle mounted 6 feet above the floor.
5. Do not connect the opener to power source until instructed to do so.
6. Locate the Door Control within sight of the door at a minimum height of 5 feet where small children cannot reach and away from all moving parts of the door.
7. Install the User Safety Instruction Label on the wall adjacent to the control button and the Maintenance Instruction Label in a prominent location on the inside of the garage door.
8. Upon completion of the installation, the door must reverse when it comes in contact with a one-inch high object or a 2x4 laid flat on the floor.
9. Do not wear watches, rings or loose clothing while installing or servicing an opener. Jewelry or loose clothing can be caught in the mechanism of the garage door or the opener.

Installation Step 1

Determine Header Bracket Location

Installation procedures vary according to garage door types. Follow the instructions which apply to your door.



WARNING

If the header bracket is not rigidly fastened to a structural support on the header wall or ceiling, the safety reverse system may not work properly (see page 30). *The door might not reverse when required, and could cause serious injury or death.*

The garage door springs, cables, pulleys, brackets and their hardware are under extreme tension. *Do not attempt to loosen, move or adjust them yourself. Serious personal injury or death could result. Call for professional garage door service.*

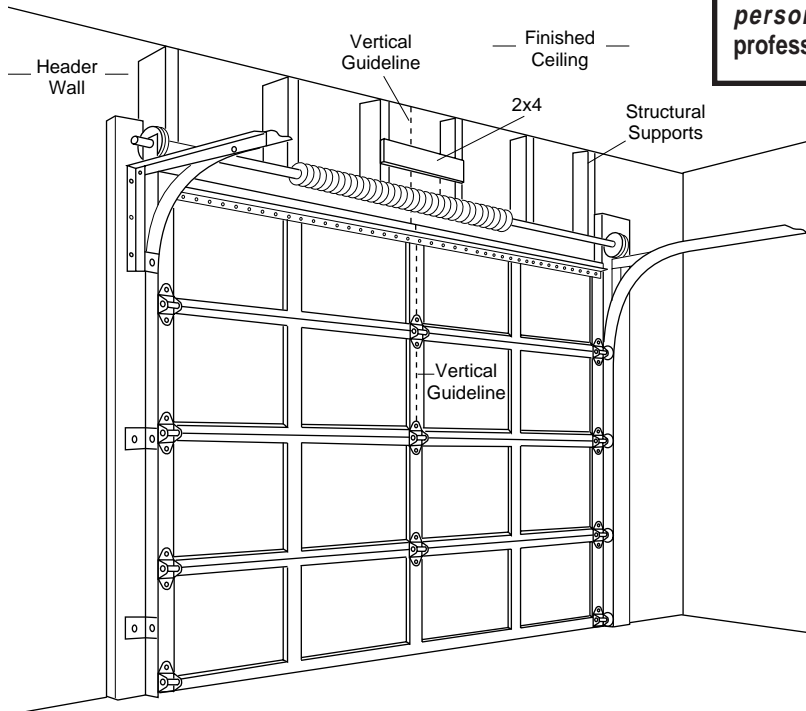

SECTIONAL Door or ONE PIECE Door with Track

- Close the door and mark the inside vertical centerline of the garage door.
- Extend the line onto the header wall above the door.

Remember, you can fasten the header bracket within 4 feet of the left or right of the door center *only* if a torsion spring or center bearing plate is in the way; or you can attach it to the ceiling (refer to page 14) when clearance is minimal. (It may be mounted on the wall upside down if necessary, to gain approximately 1/2".)

If you need to install the header bracket on a 2x4 (on wall or ceiling), use lag screws (not supplied) to securely fasten the 2x4 to structural supports as shown here and on page 13.

- Open your door to the highest point of travel as shown. Draw an intersecting horizontal line on the header wall 3" above the high point. This height will provide travel clearance for the top edge of the door.

Proceed to Step 2, page 14.

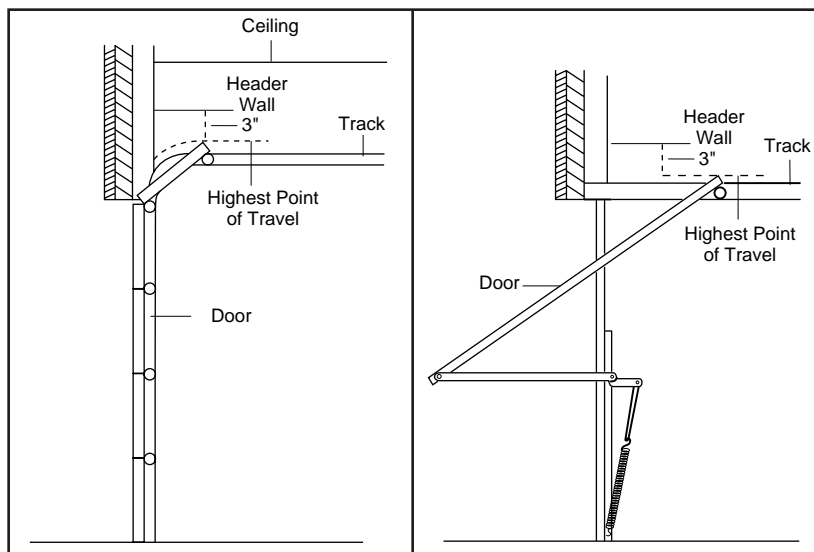

Sectional door with curved track

One-piece door with horizontal track

ONE-PIECE Door Without Track

Read the Safety Instructions on page 12. They also apply to doors without tracks.

- Close the door and mark the inside vertical centerline of your garage door. Extend the line onto the header wall above door. If headroom clearance is minimal, you can install the header bracket on the ceiling. See page 14.
- If you need to install the header bracket on a 2x4 (on wall or ceiling), use lag screws (not supplied) to securely fasten the 2x4 to structural supports as shown.

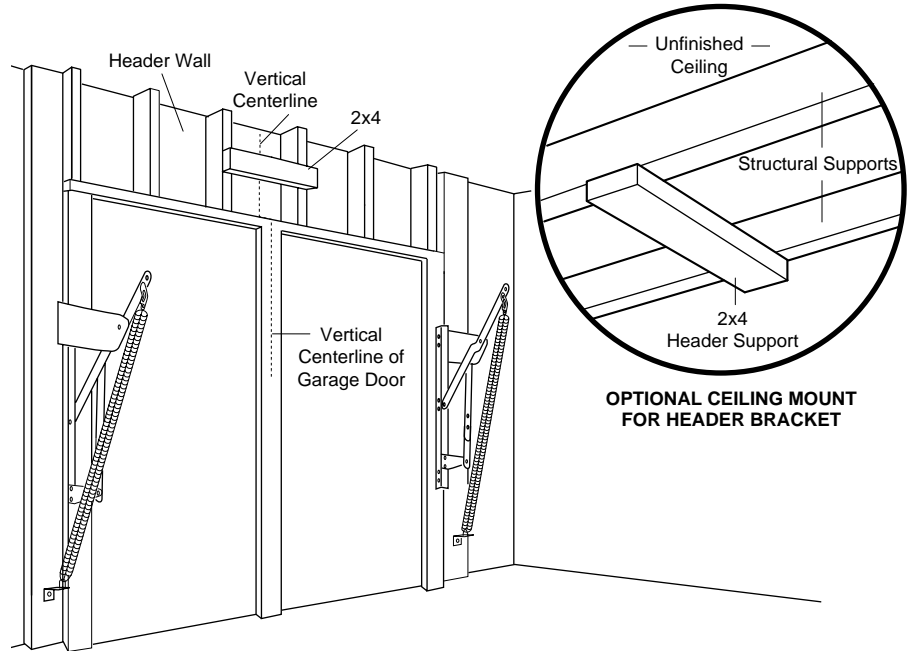

- Open your door to the highest point of travel as shown. Measure the distance from the top of the door to the floor. Subtract the actual height of the door. Add 8" to the remainder. (See Example).

- Close the door and draw an intersecting horizontal line on the header wall at the determined height.

If the total number of inches exceeds the height available in your garage, use the maximum height possible, or refer to page 14 for ceiling installation.

Proceed to Step 2, page 14.

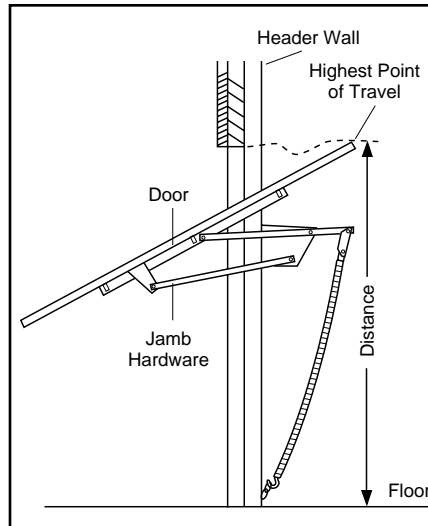

One-piece door without track jamb hardware

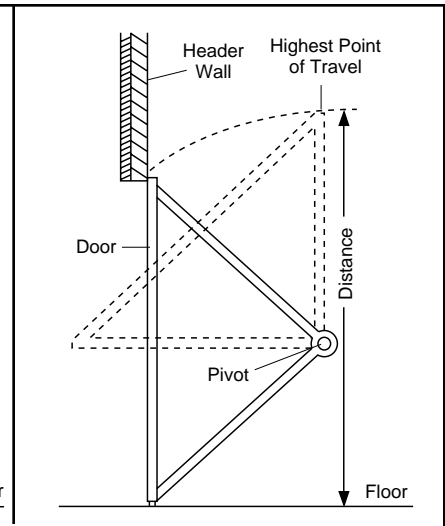

One-piece door without track pivot hardware

EXAMPLE

Distance from top of door (at highest point of travel) to floor92"
Actual height of door	<u>-88"</u>
Remainder4"
Add	<u>+8"</u>
Bracket height on header wall	=12"

(Measure UP from top of CLOSED door.)

Installation Step 2

Install the Header Bracket

You can attach the header bracket either to the wall above the garage door, or to the ceiling. Follow the instructions which will work best for your particular requirements.

Fastening the Header Bracket to the Wall

- Center the bracket on the vertical guideline with the bottom edge of the bracket on the horizontal line as shown (with the arrow pointing toward the ceiling).
- Mark either set of bracket holes (do not use the holes designated for ceiling mount). Drill 3/16" pilot holes and fasten the bracket securely to a structural support with the hardware provided.

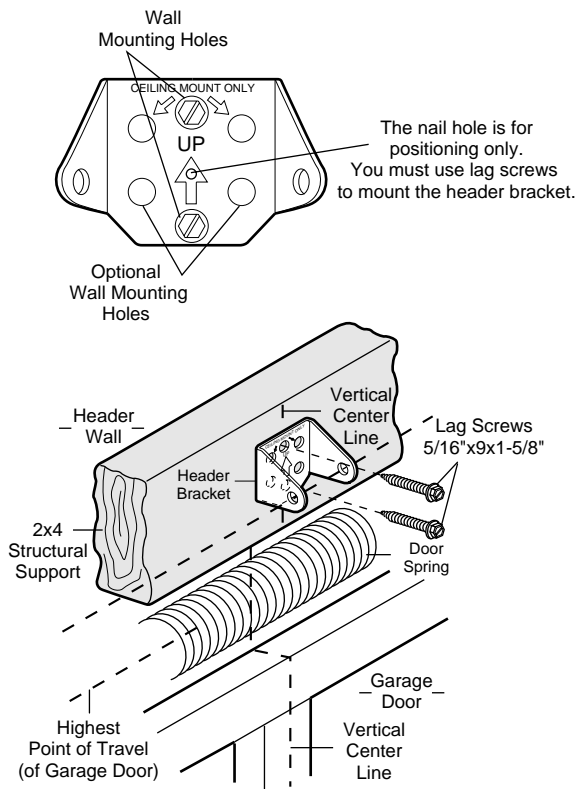

Fastening the Header Bracket to the Ceiling

- Extend the vertical guideline onto the ceiling as shown.
- Center the bracket on the vertical mark, no more than 6" from the wall. Make sure the arrow is pointing toward the wall. The bracket can be mounted flush against the ceiling when clearance is minimal.
- Mark holes designated for ceiling mount only. Drill 3/16" pilot holes and fasten bracket securely to a structural support with the hardware provided.

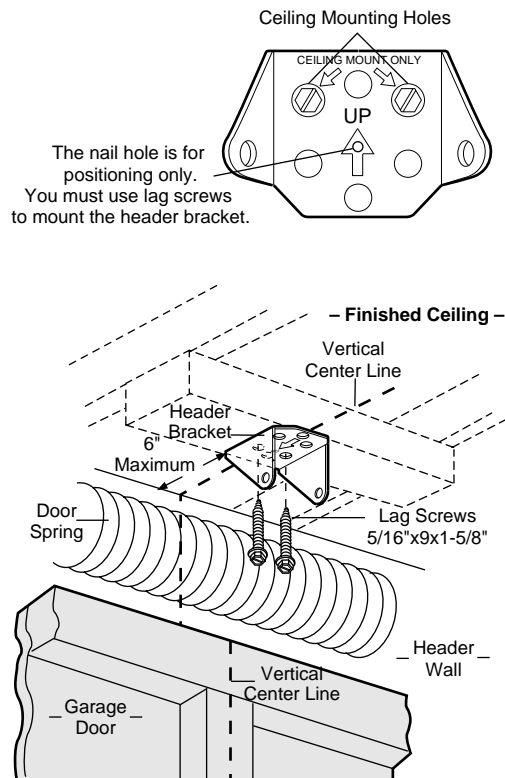

Hardware Shown Actual Size

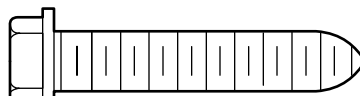

5/16" - 9 x 1-5/8"

Installation Step 3

Attach the Rail to the Header Bracket

- Position the opener on the garage floor below the header bracket. Use packing material as a protective base.

If the door spring is in the way you'll need help. Have someone hold the opener securely on a temporary support to allow the rail to clear the spring.

- Position the rail bracket against the header bracket.
- Align the bracket holes and join with a clevis pin as shown.
- Insert a ring fastener to secure.

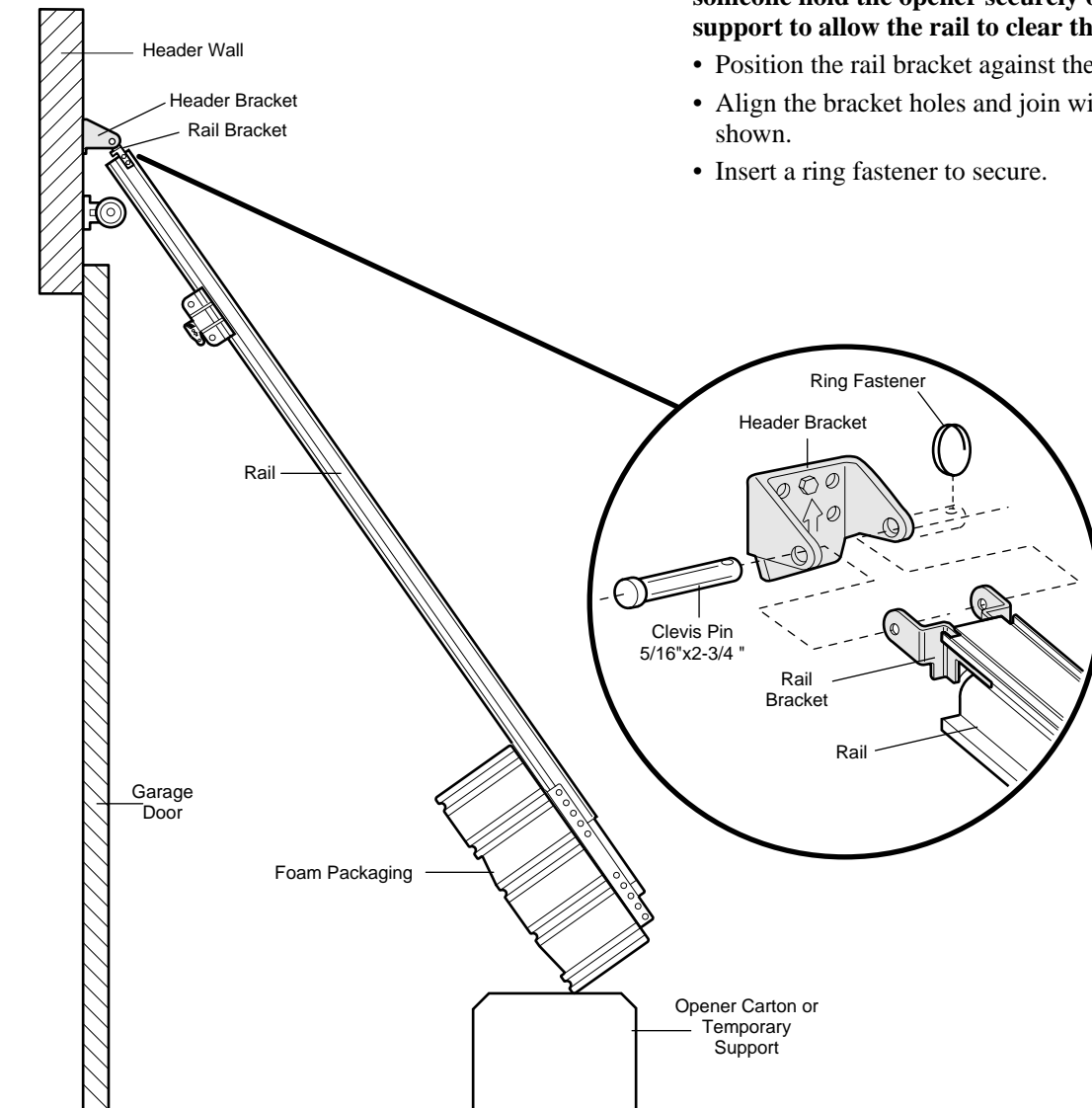

Hardware Shown Actual Size

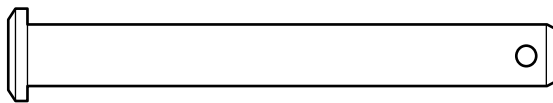

Clevis Pin
5/16" x 2-3/4"

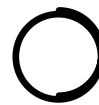

Ring Fastener

The Protector System®

IMPORTANT INFORMATION ABOUT THE SAFETY REVERSING SENSOR

The safety reversing sensor *must* be connected and aligned correctly before the garage door opener will move in the down direction. This is a required safety device and cannot be disabled.

When properly connected and aligned, the safety reversing sensor will detect an obstacle in the path of its electronic beam. The sending eye (with an orange indicator light) transmits an invisible light beam to the receiving eye (with a green indicator light). If an obstruction breaks the light beam while the door is closing, the door will stop and reverse to full open position, and the opener light will flash 10 times.

The units must be installed inside the garage so that the sending and receiving eyes face each other across the door, between 4-6" above the floor. Either can be installed on the left or right of the door as long as the sun never shines directly into the receiving eye lens.

The mounting brackets are designed to clip onto the garage door track without additional hardware.



WARNING

Without a properly working safety reversing sensor, persons (particularly children) could be injured or killed by a closing garage door. Read and follow all instructions.

To protect small children, install the safety reversing sensor so that the beam will be no higher than 4"-6" above the garage floor.

Disconnect power to the garage door opener before installing the safety reversing sensor.

If it is necessary to mount the units on the wall, the brackets must be securely fastened to a solid surface such as the wall framing. Extension brackets (see Accessories) are available if needed. If installing in masonry construction, add a piece of wood at each location to avoid drilling extra holes in masonry if repositioning is necessary.

The invisible light beam path must be unobstructed. No part of the garage door (or door tracks, springs, hinges, rollers or other hardware) may interrupt the beam while the door is closing.

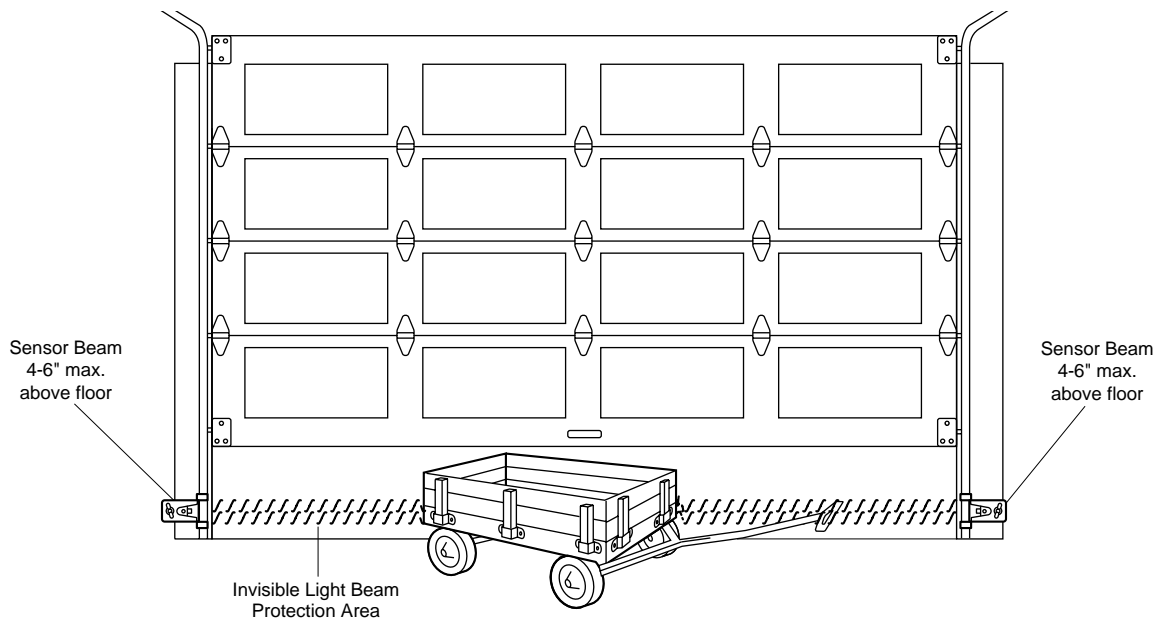

Facing the door from inside the garage

Installation Step 4

Install the Safety Reversing Sensor (Receiving and Sending Eyes)

INSTALLING THE BRACKETS

Be sure power to the opener is disconnected.

Install and align the brackets so the sensors will face each other across the garage door, with the beam from 4 – 6" above the floor.

They may be installed in one of three ways, as follows.

Garage door track installation (preferred):

- Slip the curved arms over the rounded edge of each door track, with the curved arms facing the door. Snap into place against the side of the track. It should lie flush, with the lip hugging the back edge of the track, as shown in Figure 1.

If your door track will not support the bracket securely, wall installation is recommended.

Wall installation:

- Place the bracket against the wall with curved arms facing the door. Be sure there is enough clearance for the sensor beam to be unobstructed.
- If additional depth is needed, an extension bracket (see Accessories) or wood blocks can be used.
- Use bracket mounting holes as a template to locate and drill (2) 3/16" diameter pilot holes on the wall at each side of the door, from 4–6" above the floor. (See Warning on page 16.)
- Attach brackets to wall with lag screws (not provided).
- If using extension brackets or wood blocks, adjust right and left assemblies to the same distance out from the mounting surface. Make sure all door hardware obstructions are cleared.

Floor installation:

- Use wood blocks or extension brackets (see Accessories) to elevate sensor brackets so the lenses will be 4-6" above the floor.
- Carefully measure and place right and left assemblies at the same distance out from the wall. Be sure all door hardware obstructions are cleared.
- Fasten to the floor with concrete anchors as shown.

Figure 1 DOOR TRACK MOUNT (Right Side)

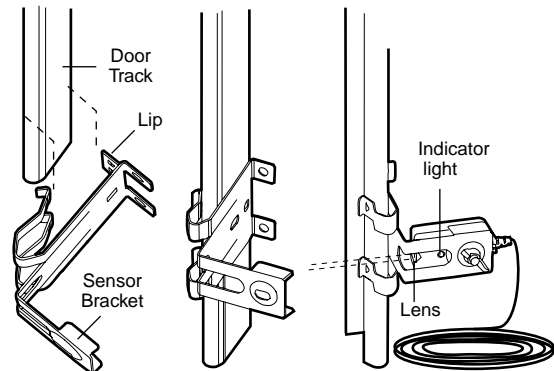

Figure 2 WALL MOUNT (Right Side)

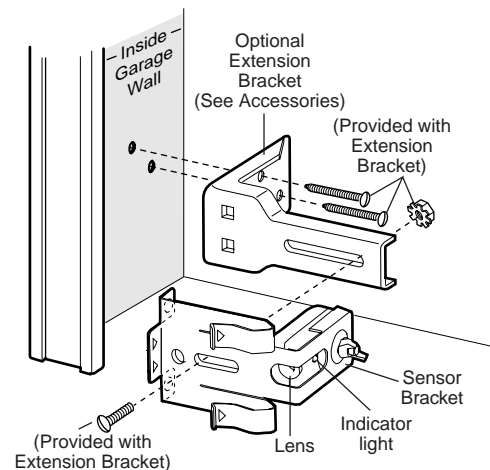
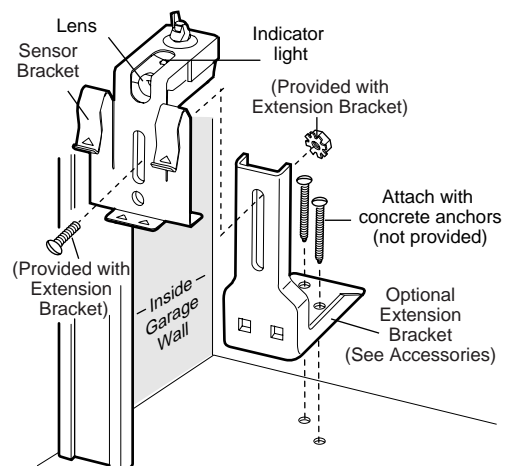

Figure 3 FLOOR MOUNT (Right Side)



Installation Step 4 (Continued)

Install the Safety Reversing Sensor

Mounting and Wiring the Safety Sensors

- Slide a 1/4"-20x1/2" carriage bolt head into the slot on each sensor. Use wing nuts to fasten sensors to brackets, with lenses pointing toward each other across the door.
- Be sure the lens is not obstructed by a bracket extension. See Figure 4.
- Finger tighten the wing nuts.

Recommended Wire Routing

1. Using insulated staples, run the wires from both sensors to the rail at the door header (see Figure 5).
2. Cross and twist the two wires where they meet the rail (see inset A). Run the wires inside the channels at the top of the rail, along each side, to the power unit and pull taut (see inset B). *Do not use the lower (trolley) channels.*

NOTE: If your access door is near the garage door, you may choose to install the door control at this time and run the door control wire along the rail with the sensor wires. Use one rail channel for the door control wire and the other channel for both sensor wires. If you choose this option, follow instructions 1-3 on page 21 now.

3. Thread the wires through the tabs on top of the drive shaft cover.
4. With your screwdriver tip, tuck the wires snugly into the rail channels. You will complete the wiring in Installation Step 7.

Figure 4

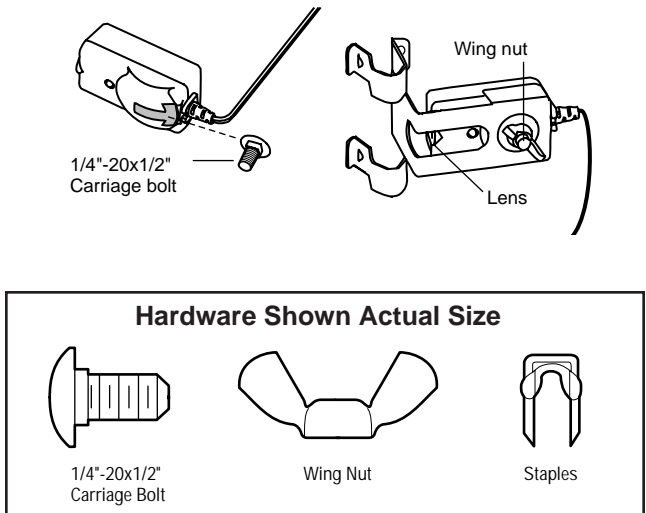
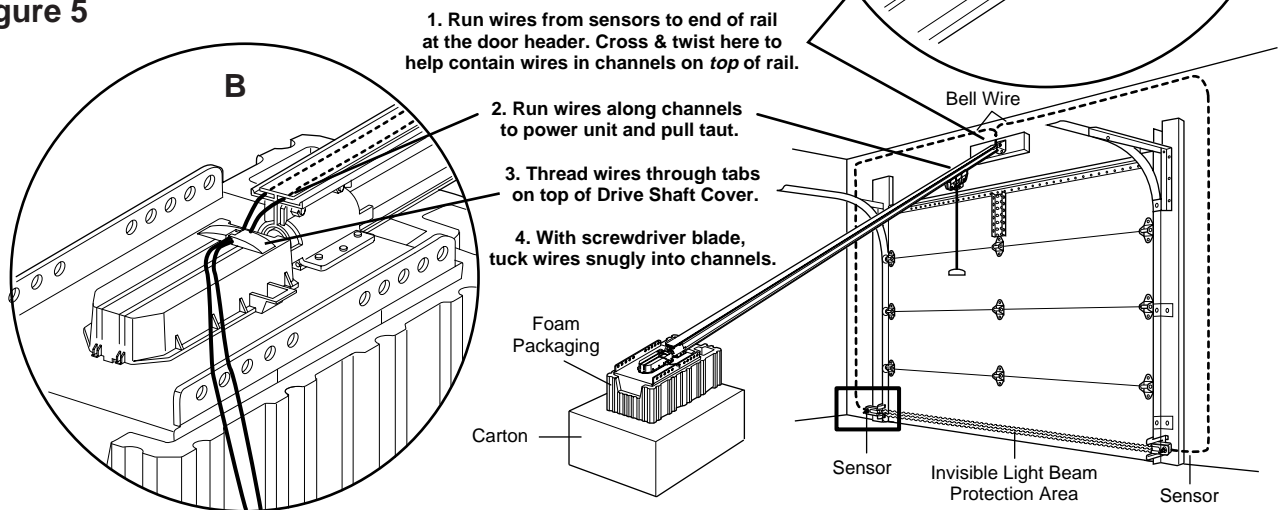

Figure 5



Installation Step 5

Position the Opener

Follow instructions which apply to your door type as illustrated.



CAUTION

To prevent damage to steel, aluminum, fiberglass or glass panel doors, do not rest the opener on the door without using a 2x4.

SECTIONAL Door or ONE-PIECE Door with Track

A 2x4 laid flat is convenient for setting an ideal door-to-rail distance.

- Raise the opener onto a stepladder.

You will need help at this point if the ladder is not tall enough.

- Open the door all the way and place a 2x4 laid flat on the top section beneath the rail.

If the top panel hits the trolley when you raise the door, pull down on the trolley release arm to disconnect the inner and outer sections. The trolley can remain disconnected until Step 13 is completed.

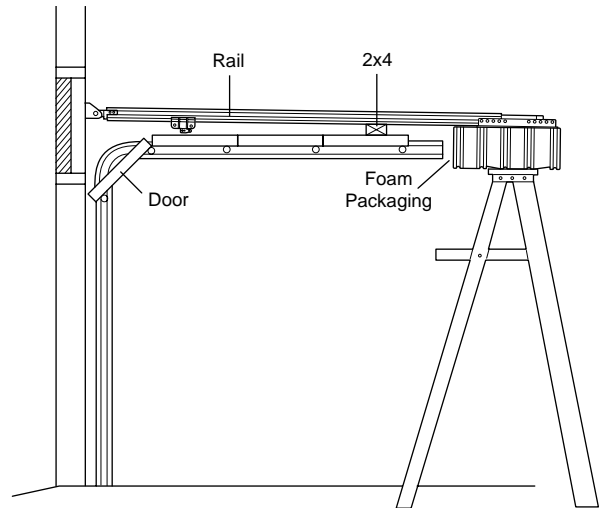
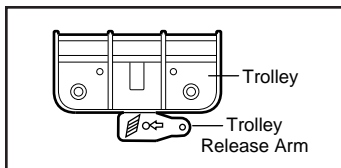

ONE-PIECE Door without Track

- With the door fully open and parallel to the floor, measure the distance from the floor to the top of the door.
- Using a stepladder as a support, raise the opener to the same distance as the door from the floor (it will be at a slight angle as shown).
- The top of the door should be level with the top of the opener. Do not position the opener more than 3" above this point.

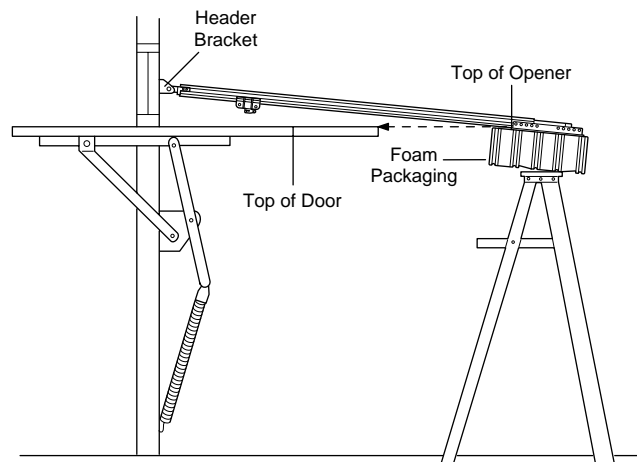

Installation Step 6

Hang the Opener

Two representative installations are shown. Yours may be different. Hanging brackets should be angled, Figure 1, to provide rigid support. On finished ceilings, Figure 2, attach a sturdy metal bracket to structural supports before installing the opener. *The bracket and fastening hardware are not supplied.*

1. Measure the distance from each side of the opener to the structural support.
2. Cut both pieces of the hanging bracket to required lengths.
3. Drill $3/16$ " pilot holes in the structural supports.
4. Attach one end of each bracket to a support with $5/16$ " - $18 \times 1-7/8$ " lag screws.
5. Fasten the opener to the hanging brackets with $5/16$ " - $18 \times 7/8$ " screws, lock washers and nuts.
6. Check to make sure the rail is centered over the door (or in line with the header bracket if the bracket is not centered above the door).
7. Remove the 2x4. Operate the door manually. If the door hits the rail, raise the header bracket.

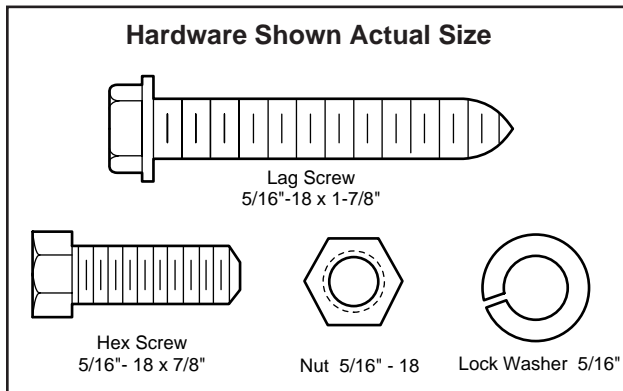

WARNING

The opener could fall and injure someone if it is not properly secured. Fasten the opener securely to structural supports of the garage.

Figure 1

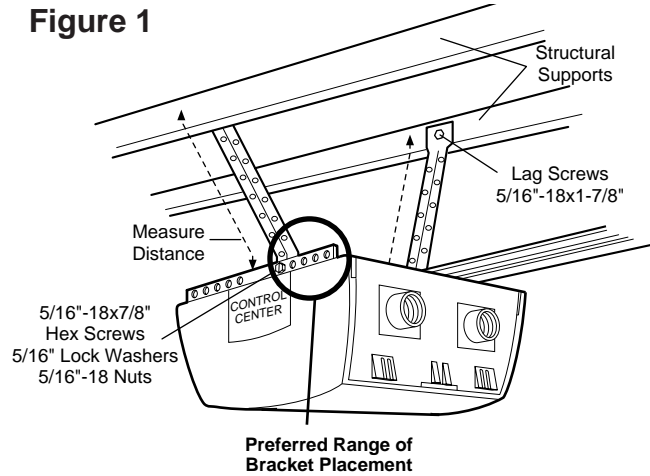
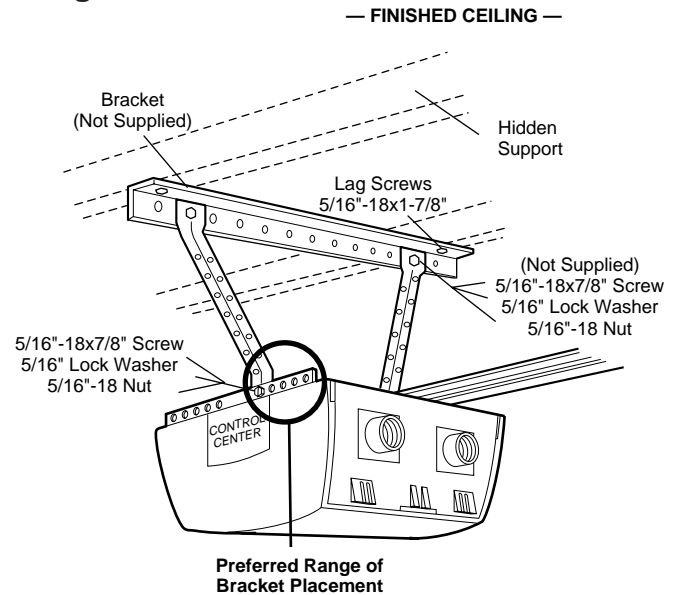

Figure 2



Installation Step 7

Install the Door Control and Connect all Wiring

Locate the door control within sight of the door at a minimum height of 5 feet where small children cannot reach, and away from all moving parts of the door and door hardware.

The multi-function door control is typically attached directly to the wall, see Figure 1. For pre-wired installations (as in new home construction), it may be mounted to a standard single gang box, see Figure 2.

- Strip 1/4" of insulation from one end of the bell wire.
Connect the wire to the two screw terminals on the back of the door control as follows: white wire to 2 and white/red wire to 1. (**NOTE:** After installation, a green indicator light behind the white translucent cover will indicate proper connection. If not lit, the Lock and Light features will not function (reverse wires to correct).
- Before mounting, remove the white cover by gently pushing both thumbs against the upper corners of the cover on the back side of the door control.
 - For standard wall mount, mark the wall about 1-1/4" up the centerline from the bottom of the door control. Install a 6ABx1-1/4" self-tapping screw at this point, allowing about 1/8" to protrude from the wall. Slip the lower part of the door control over the screw head and adjust for snug fit. Drill and install the top screw with care to avoid cracking the plastic housing. *Do not overtighten.* Run the bell wire up the wall and across the ceiling to the opener. Use insulated staples to secure the wire in several places. Be careful not to pierce the wire with a staple, creating a short. *If your access door is near the garage door, you may run this wire with the Safety Reversing Sensor wires along the top of the rail. See page 18.*
 - For pre-wired installations, partially install a 6-32x1" machine screw into the bottom of the gang box, allowing about 1/8" to protrude. Slip the lower part of the door control over the screw head and adjust for snug fit. Install top screw with care to avoid cracking plastic housing. *Do not overtighten.*
- Remove the Control Center door on the right panel of the opener to access the terminal screws.
- Thread all wires through the opening at the base of the drive shaft cover, see Figure 3.
- Insert the remaining wire through the hole in the power unit and strip 1/4" of insulation from each set of wires.
- Connect the door control wire to the opener terminal screws: white to 2 and white/red to 1.
- Separate the sensor white and white/black wires sufficiently to connect to the opener terminal screws: white to 2 and white/black to 3.
- Attach the User Safety Instruction label to the wall near the door control, and the Maintenance Instruction label in a prominent location on the inside of the garage door.
- Replace the cover by inserting bottom tabs and snapping into place. To remove the cover after mounting, gently pry at the top with a paper clip or small flat head screwdriver.

Page 32 explains how to operate the opener using the door control.

Do NOT connect the power and operate the opener at this time. See Step 9 on page 22.



WARNING

Do not connect to live electrical wiring. Connect only to 24 Volt low voltage wires. Connection to live wires or higher voltage may cause serious injury from shock, burn or electrocution.

Children operating or playing with a garage door opener can injure themselves or others. *The garage door could close and cause serious injury or death.* Do not allow children to operate the push button(s) or the remote control(s).

A moving garage door could injure someone under it. Activate the opener only when the door is properly adjusted, you can see it clearly, and there are no obstructions to door travel.

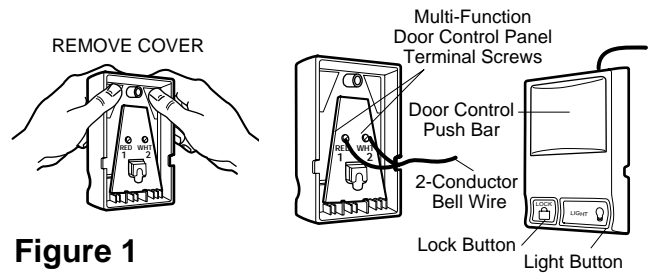

Figure 1

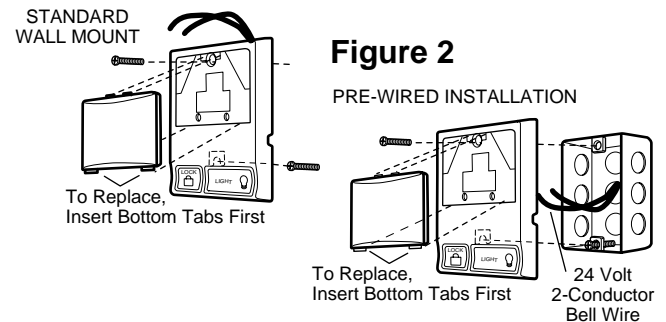

Figure 2

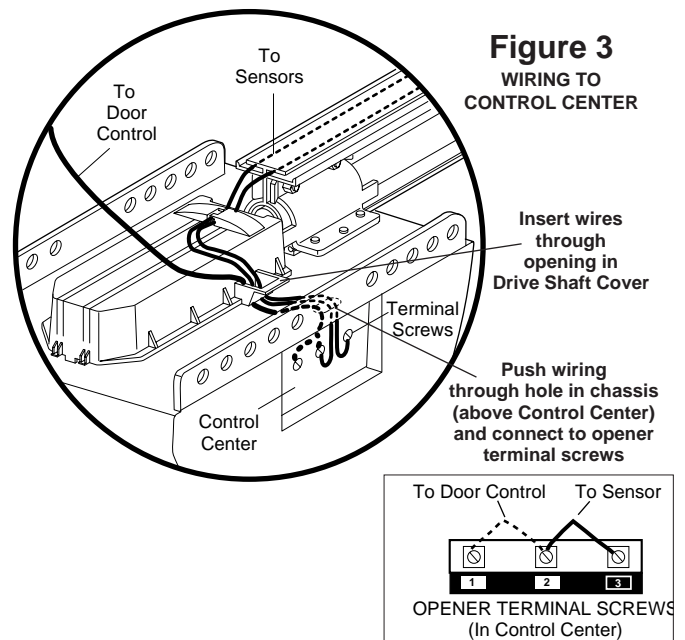
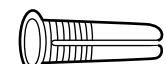

Figure 3
WIRING TO
CONTROL CENTER

Hardware Shown Actual Size



Insulated Staples



Dry Wall Anchors

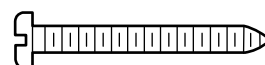

6ABx1-1/4" Screw
Multi-Function Door Control Panel

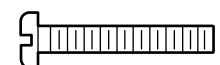

Screw 6-32 x 1"

Installation Step 8

Electrical Requirements

To reduce the risk of electric shock, your garage door opener has a grounding type plug with a third grounding pin. This plug will *only* fit into a grounding type outlet. If the plug doesn't fit into the outlet you have, contact a qualified electrician to install the proper outlet.

To avoid installation difficulties, do not run the opener until Step 9 below.

If permanent wiring is required by your local code, refer to the following procedure:

WARNING

To prevent electrocution, remove power from the garage door opener and from the circuit you plan to use for the permanent connection.

To make a permanent connection through the 7/8" diam. hole in the top of the opener (according to local code):

- Remove the opener cover screws and set the cover aside.
- Remove the attached 3-prong cord.
- Connect the black (line) wire to the screw on the brass terminal; the white (neutral) wire to the screw on the silver terminal; and the ground wire to the green ground screw. **The opener must be grounded.**
- Reinstall the cover.

Installation Step 9

Complete Safety Reversing Sensor Installation

Aligning the Safety Sensors

- Plug in the opener. The indicator lights in both the sending and receiving eyes will *glow steadily* if wiring connections and alignment are correct.

The sending eye orange indicator light will glow regardless of alignment or obstruction. If the green indicator light in the *receiving eye* is off, dim, or flickering (and the invisible light beam path is not obstructed), alignment is required.

- Loosen the *sending* eye wing nut and re-adjust, aiming directly at the receiving eye. Lock in place.
- Loosen the *receiving* eye wing nut and adjust sensor vertically and/or horizontally until it receives the sender's beam. When the green indicator light *glows steadily*, tighten the wing nut.

WARNING

To prevent electrocution or fire, installation and wiring must be in compliance with local electrical and building codes.

Do NOT use an extension cord, 2-wire adapter, or change the plug in any way to make it fit your outlet.

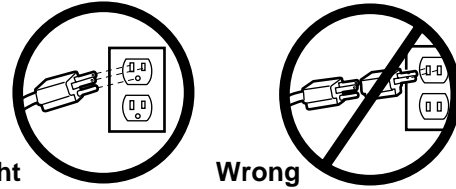

Right

Wrong

Permanent Wiring Connection

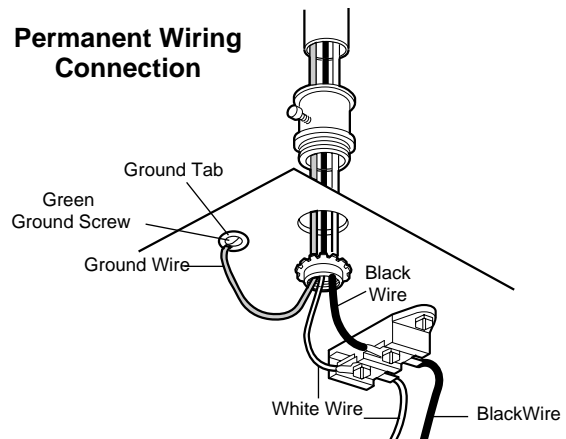

Trouble Shooting

1. If the *sending eye* indicator light does not *glow steadily* after installation, check for:
 - Electric power to the opener.
 - A short in the white or white/black wires. These can occur under staples or at screw terminal connections.
 - Incorrect wiring between sensors and opener.
 - A broken wire.
2. If the sending eye indicator light *glows steadily* but the receiving eye indicator light doesn't:
 - Check alignment.
 - Check for an open wire to the receiving eye.
3. If the receiving eye indicator light is dim, realign either sensor.

NOTE: When the invisible beam path is obstructed or misaligned while the door is closing, the door will reverse. If the door is already open, it will not close. The opener lights will flash 10 times. (If bulbs are not installed, 10 clicks are audible.) See page 16.

Installation Step 10

Install the Lights and Lens

- Install a 100 watt maximum light bulb in each socket. The lights will turn ON and remain lit for approximately 4-1/2 minutes when power is connected. Then the lights will turn OFF.
- Insert bottom lens tabs into slots on chassis and tilt towards chassis to engage top tabs, then drop down gently into place. (See illustration.)
- To remove, lift lens up and *gently* tilt slightly outward and down, then pull out to clear bulbs. **Use care to avoid snapping off bottom lens tabs.**
- If the bulbs burn out prematurely, replace with *standard neck* Garage Door Opener bulbs. (Fluorescent bulbs are not recommended because of possible interference with receiver/transmitter signals.)

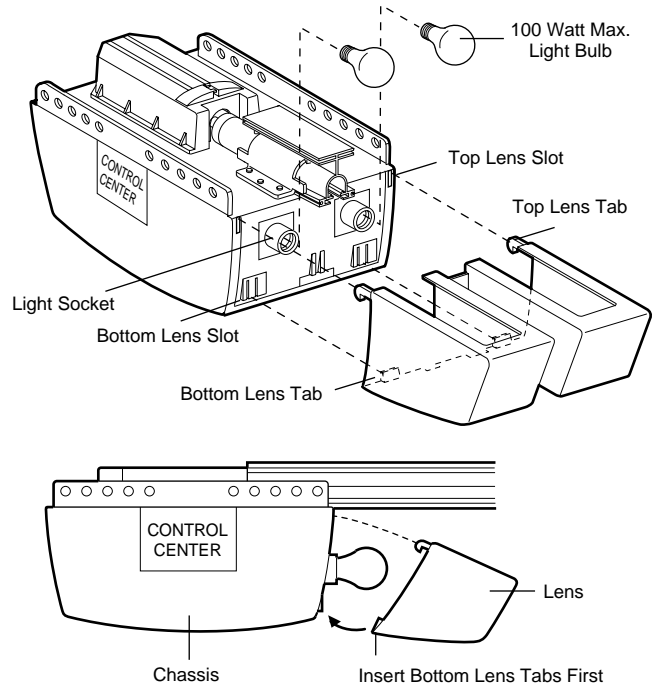

Installation Step 11

Attach the Manual Release Rope and Handle

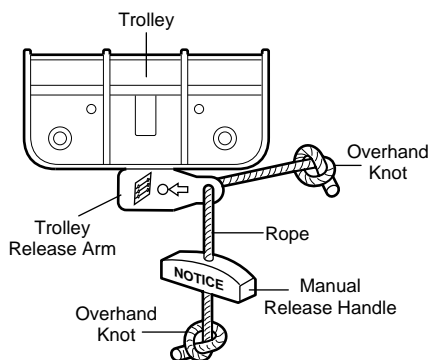

WARNING

Do not use the red handle to pull the door open or closed. *The rope knot could become untied and you could fall.* Use the manual release only to disengage the trolley and, if possible, only when the door is closed.

Garage doors are heavy. If the door is open when the handle is pulled, the door could close inadvertently if it is not properly balanced. Serious injury may result to persons under the door. Make sure the doorway is clear of persons and obstructions before pulling handle when door is open.

- Thread one end of the rope through the hole in the top of the red handle so "NOTICE" reads right side up as shown. Secure with an overhand knot at least 1" from the end of the rope to prevent slipping.
- Thread the other end of the rope through the hole in the release arm of the outer trolley.
- Adjust rope length so the handle is 6 feet above the floor. Secure with an overhand knot .

If it is necessary to cut the rope, heat seal the cut end with a match or lighter to prevent unraveling.

Installation Step 12

Fasten Door Bracket

Follow instructions which apply to your door type as illustrated below or on page 25.



CAUTION

To prevent damage to steel, aluminum, fiberglass or glass panel doors, always reinforce the inside of the door both vertically and horizontally with an angle iron.

A horizontal brace should be long enough to be secured to 2 vertical supports. A vertical brace should cover the height of the top panel.

The illustration shows one piece of angle iron as the horizontal brace. For the vertical brace, 2 pieces of angle iron are used to create a U-shaped support. The best solution is to check with your garage door opener installation door reinforcement kit.

SECTIONAL Door Installation Procedure

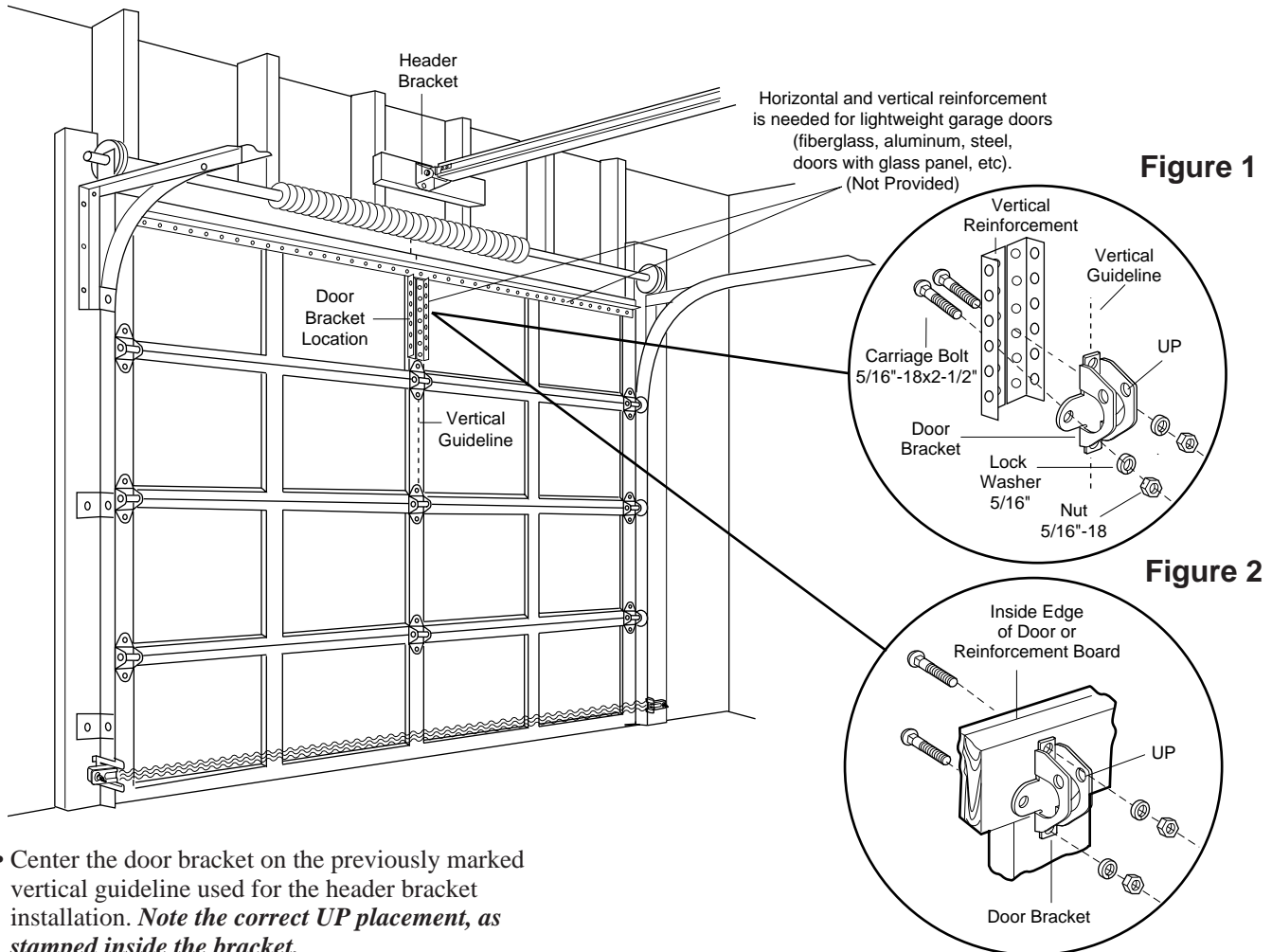

- Center the door bracket on the previously marked vertical guideline used for the header bracket installation. *Note the correct UP placement, as stamped inside the bracket.*
- Position the bracket on the face of the door within the following limits:
 - A) The top edge of the bracket 2-4" below the top edge of the door.
 - B) The top edge of the bracket directly below any structural support across the top of the door.
- Mark and drill 5/16" left and right fastening holes. Secure the bracket as shown in Figure 1 if there is vertical reinforcement.

If your installation doesn't require vertical reinforcement but does need top and bottom fastening holes for the door bracket, fasten as shown in Figure 2.

Hardware Shown Actual Size

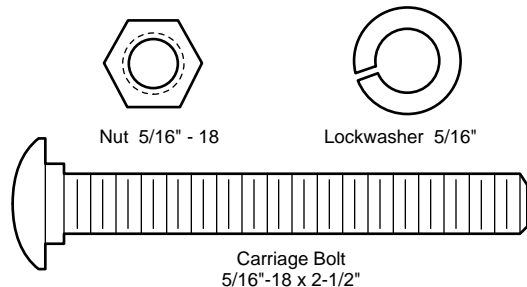

All ONE-PIECE Door Installation Procedure

Please read and comply with the warnings and reinforcement instructions on page 24. They apply to one-piece doors also.

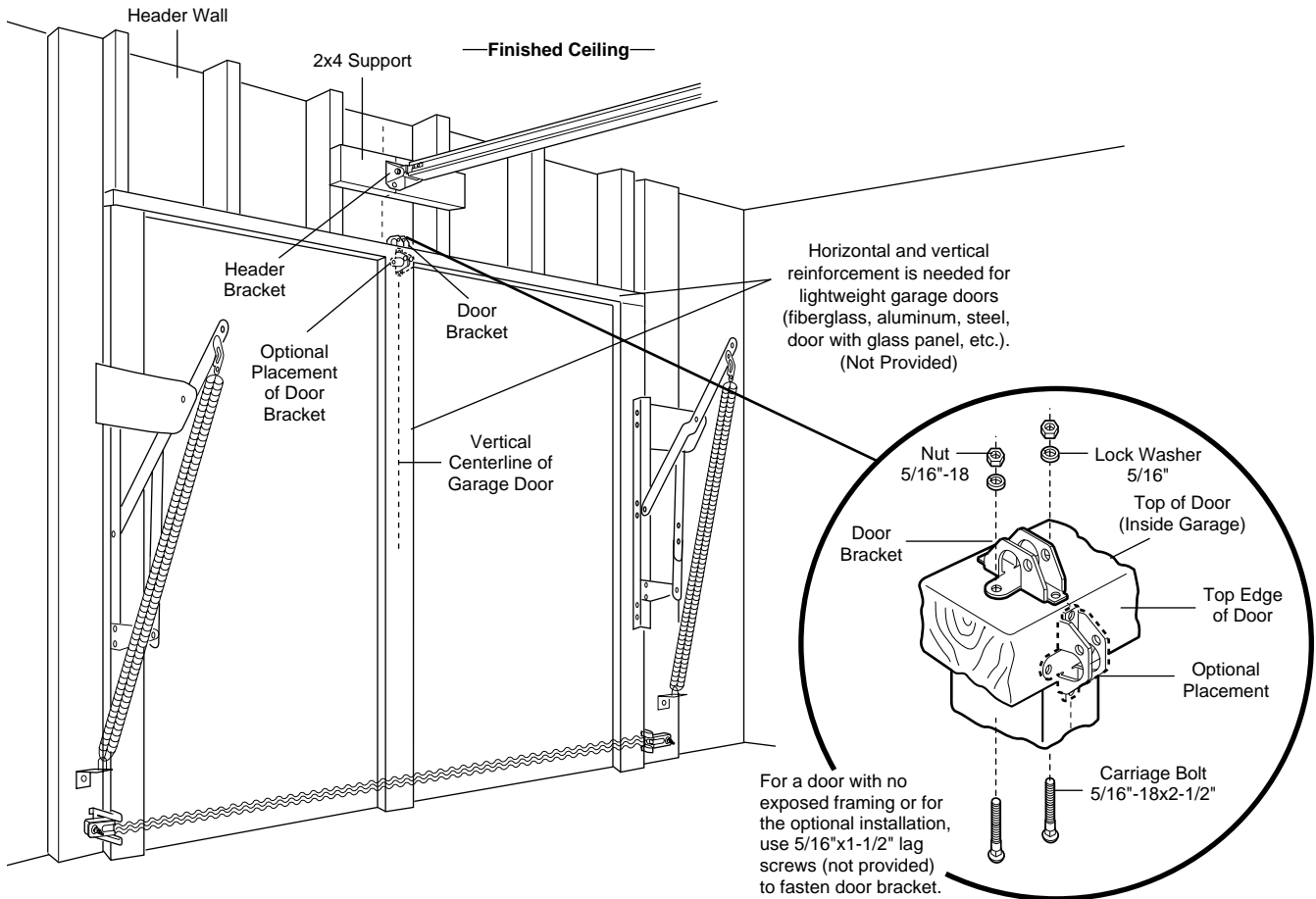

- Center the bracket on the top of the door, in line with the header bracket as shown. Mark holes.
- Drill 5/16" pilot holes and fasten the door bracket with hardware provided.

If the door has no exposed framing, drill 3/16" pilot holes and fasten the bracket with 5/16"x1-1/2" lag screws (not provided) to the top of the door.

The door bracket may be installed on the top edge of the door if required for your installation. (Refer to the dotted line optional placement drawing.) Drill 3/16" pilot holes and substitute 5/16"x1-1/2" lag screws (not provided) to fasten the bracket to the door.

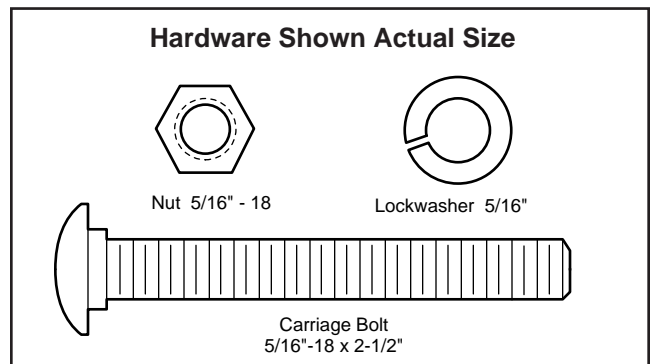

Installation Step 13

Connect Door Arm to Trolley

Follow instructions which apply to your door type as illustrated below and on page 27.

SECTIONAL Doors Only

Make sure garage door is fully closed. Pull the manual release handle to disconnect the outer trolley from the inner trolley. Slide the outer trolley back (away from the door) about 2" as shown in Figures 1, 2 and 3.

Figure 1:

- Fasten straight door arm section to outer trolley with the 5/16"x1" clevis pin. Secure the connection with a ring fastener.
- Fasten curved section to the door bracket in the same way, using the 5/16"x1-1/4" clevis pin.

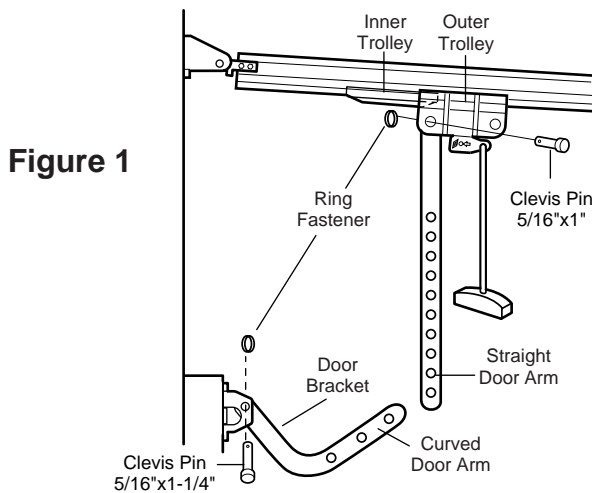
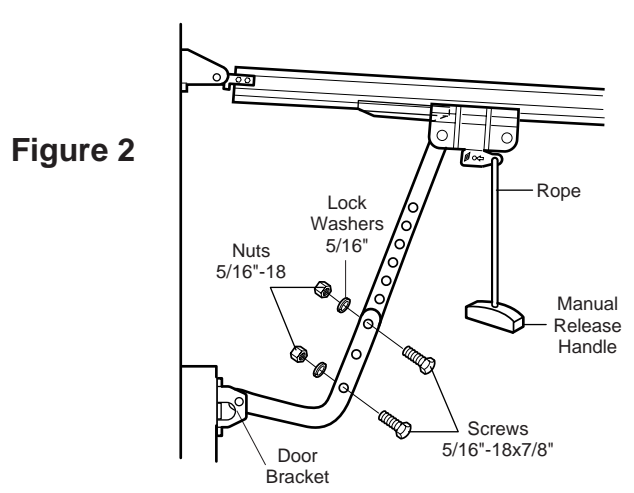

Figure 2:

- Bring arm sections together. Find two pairs of holes that line up and join sections. Select holes as far apart as possible to increase door arm rigidity.



Hole Alignment Alternative

Figure 3:

- If holes in curved arm are *above* holes in straight arm, disconnect straight arm. Cut about 6" from the solid end. Reconnect to trolley with *cut end down* as shown.
- Bring arm sections together.
- Find two pairs of holes that line up and join with screws, lock washers and nuts.

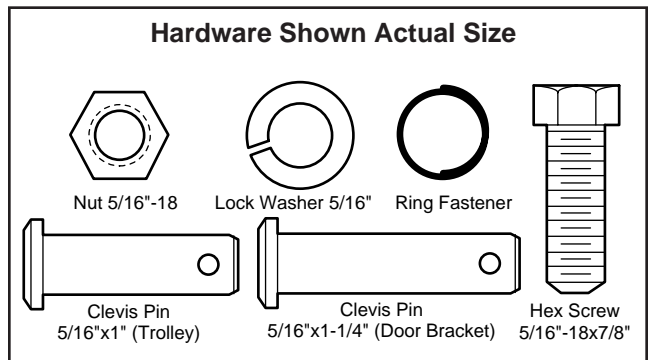
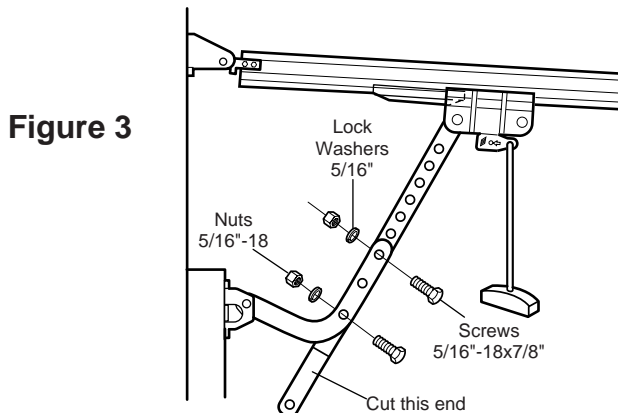

Proceed to Adjustment Step 1, page 28. Trolley will re-engage automatically when the opener is operated.

All ONE-PIECE Doors

Assemble the Door Arm:

- Fasten the straight and curved door arm sections together to the longest possible length (with a 2 or 3 hole overlap).
- With the door closed, connect the straight door arm section to the door bracket with the 5/16"x1-1/4" clevis pin.
- Secure with a ring fastener.

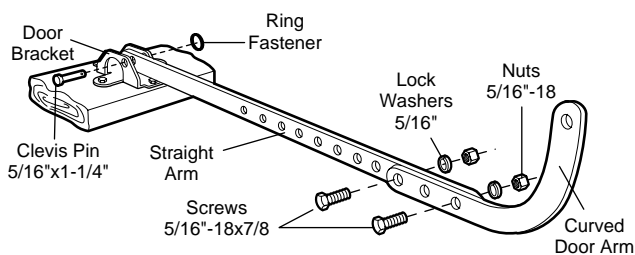

Adjustment Procedures for One-Piece Doors

On one-piece doors, before connecting the door arm to the trolley the travel limits must be adjusted. Limit adjustment screws are located on the right side panel as shown on page 28. Follow adjustment procedures below.

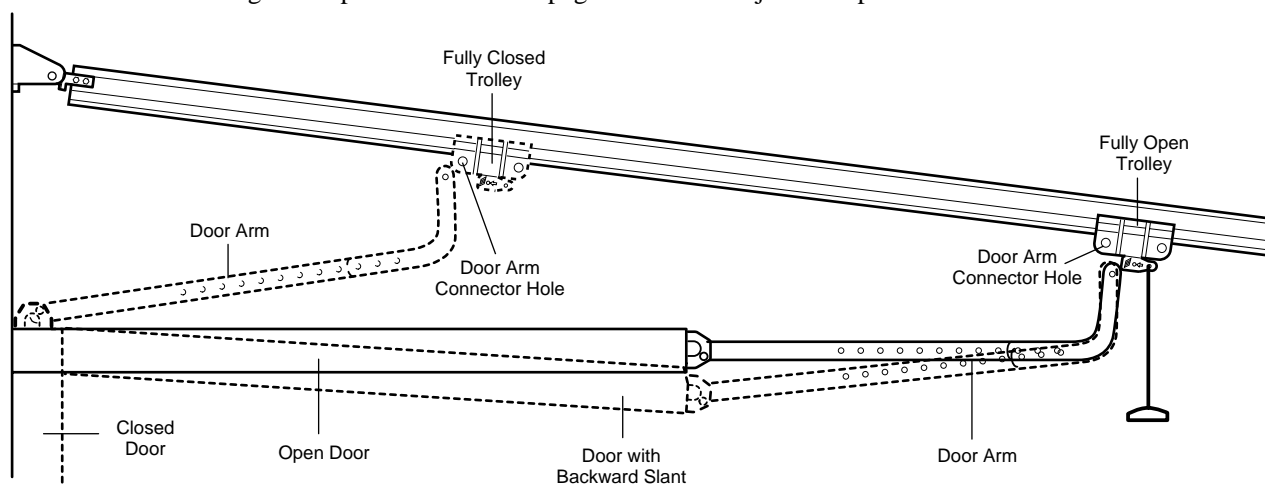

Open Door Adjustment: Decrease UP Travel Limit

- Turn the UP limit adjustment screw counter-clockwise 5 1/2 turns.
- Press the Door Control push bar. The trolley will travel to the fully open position.
- Manually raise the door to the open position (parallel to the floor), and lift the door arm to the trolley. The arm should touch the trolley just in back of the door arm connector hole. Refer to the fully open trolley/door arm positions in the illustration. If the arm does not extend far enough, adjust the limit further. One full turn equals 2" of trolley travel.

Closed Door Adjustment: Decrease DOWN Travel Limit

- Turn the DOWN limit adjustment screw clockwise 5 complete turns.
- Press the Door Control push bar. The trolley will travel to the fully closed position.
- Manually close the door and lift the door arm to the trolley. The arm should touch the trolley just ahead of the door arm connector hole. Refer to the fully closed trolley/door arm positions in the illustration. If the arm is behind the connector hole, adjust the limit further. One full turn equals 2" of trolley travel.

Connect the Door Arm to the Trolley:

- Close the door and join the curved arm to the connector hole in the trolley with the remaining clevis pin. **It may be necessary to lift the door slightly to make the connection.**
- Secure with a ring fastener.
- Run the opener through a complete travel cycle. If the door has a slight "backward" slant in full open position as shown in the illustration, decrease the UP limit until the door is parallel to the floor.

Adjustment Step 1

Adjust the UP and DOWN Limits

Do not make any limit adjustments until the safety reversing sensors are completely installed.

Limit adjustment settings regulate the points at which the door will *stop* when moving up or down.

The door will *stop* in the *up* direction if anything interferes with door travel. The door will *reverse* in the *down* direction if anything interferes with the door travel (including binding or unbalanced doors).

To operate the opener, press the Door Control push bar. Run the opener through a complete travel cycle.

- Does the door open and close completely?
- Does the door stay closed and not reverse unintentionally when fully closed?

If your door passes both of these tests, no limit adjustments are necessary unless the reversing test fails (see page 30).

Adjustment procedures are outlined below. **Run the opener through a complete travel cycle after each adjustment.**

Repeated operation of the opener during adjustment procedures may cause the motor to overheat and shut off. Simply wait 15 minutes and try again.

Read the procedures carefully before proceeding to Adjustment Step 2. Use a screwdriver to make limit adjustments.



WARNING

Improper adjustment of the travel limits will interfere with the proper operation of the safety reverse system. *The door might not reverse properly when required and could seriously injure or kill someone under it. Test the safety reverse system monthly, and following all adjustments to the travel limits. See page 30.*

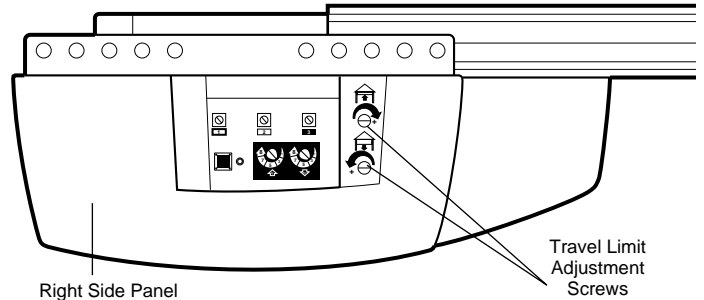

LIMIT ADJUSTMENT LABEL

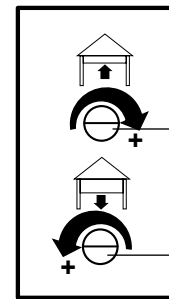

How and When to Adjust the Limits

If the door does not open completely but opens at least five feet:

Increase *up* travel. Turn the UP limit adjustment screw clockwise. One turn equals 2" of travel.

If door does not open at least 5 feet: Adjust the UP (open) force as explained in Adjustment Step 2.

If the door does not close completely:

Increase *down* travel. Turn the DOWN limit adjustment screw counterclockwise. One turn equals 2" of travel.

If door still won't close completely, try lengthening the door arm. (Page 26.)

If you have adjusted the door arm to the maximum length and the door still will not close completely, lower the header bracket. See Installation Step 1, pages 12 and 13.

If the opener reverses in fully closed position:

Decrease *down* travel. Turn the DOWN limit adjustment screw clockwise. One turn equals 2" of travel.

If the door reverses when closing and there is no visible interference to travel cycle:

If the opener lights are flashing, the Safety Reversing Sensors are either not installed, misaligned, or obstructed. See Troubleshooting, page 22.

Test the door for binding: Pull the manual release handle. Manually open and close the door. If the door is binding, call for garage door service. If the door is not binding or unbalanced, adjust the DOWN (close) force. See Adjustment Step 2.

Adjustment Step 2

Adjust the Force

Force adjustment controls are located on the right panel of the opener. Force adjustment settings regulate the amount of power required to open and close the door.

The door will *stop* in the *up* direction if anything interferes with its travel. The door will *reverse* in the *down* direction if anything interferes with its travel (including binding or unbalanced doors).

If the forces are set too light, door travel may be interrupted by *nuisance reversals* in the *down* direction and *stops* in the *up* direction. Weather conditions can affect the door movement, so occasional adjustment may be needed.

The maximum force adjustment range is about 3/4 of a complete turn. Do not force controls beyond that point. Turn force adjustment controls with a screwdriver.

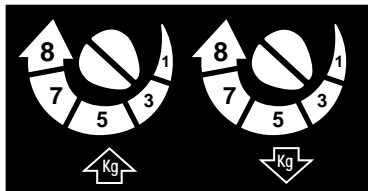

Force Adjustment Label



WARNING

Too much force on the door will interfere with the proper operation of the safety reverse system. *The door might not reverse properly when required and could seriously injure or kill someone under it. Do not increase the force beyond the minimum amount required to close the door. Do not use the force adjustments to compensate for a binding or sticking garage door. Test the safety reverse system monthly, and following all adjustments to force levels. See page 30.*

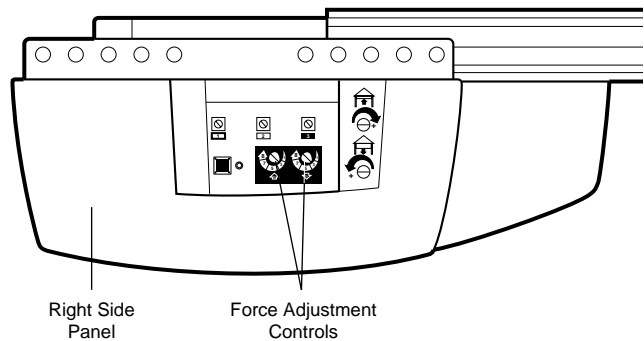

How and When to Adjust the Forces

Test the DOWN (close) force

Grasp the door bottom when the door is about halfway through DOWN (close) travel. The door should reverse.

Reversal halfway through down travel does not guarantee reversal on a one-inch obstruction. See page 30. If the door is hard to hold or doesn't reverse, decrease the DOWN (close) force by turning the control counterclockwise.

Make small adjustments until the door reverses normally. After each adjustment, run the opener through a complete cycle.

Test the UP (open) force

Grasp the door bottom when the door is about halfway through UP (open) travel. The door should stop. If the door is hard to hold or doesn't stop, decrease UP (open) force by turning the control counterclockwise.

Make small adjustments until the door stops easily. After each adjustment, run the opener through a complete travel cycle.

If the door doesn't open at least 5 feet:

Increase UP (Open) force by turning the control clockwise. Make small adjustments until door opens completely. Readjust the UP limit if necessary. After each adjustment, run the opener through a complete travel cycle.

If the door reverses during the down (close) cycle and the opener lights aren't flashing:

Increase DOWN (close) force by turning the control clockwise. Make small adjustments until the door completes a close cycle. After each adjustment, run the opener through a complete travel cycle. **Do not increase the force beyond the minimum amount required to close the door.**

Adjustment Step 3

Test The Protector System®

- Press the remote control push button to open the door.
- Place the opener carton in the path of the door.
- Press the remote control push button to close the door.
The door will not move more than an inch, and the opener light will flash for 5 seconds.

Professional service is required if the opener closes the door when the safety reversing sensor is obstructed.

The garage door opener will not close from a remote if the indicator light in either sensor is off (alerting you to the fact that the sensor is misaligned or obstructed).

The garage door can be closed by pressing and *holding* the Door Control push bar until down travel is completed.



WARNING

Without a properly working safety reversing sensor, persons (particularly children) could be seriously injured or killed if trapped by a closing garage door. Repeat this test once a month.

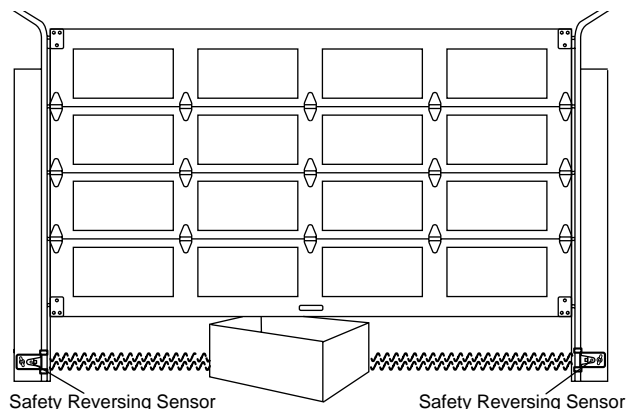

Adjustment Step 4

Test the Safety Reverse System

Test

- With the door fully open, place a one-inch board (or a 2x4 laid flat) on the floor, centered under the garage door.
- Operate the door in the down direction. ***The door must reverse on striking the obstruction.***

Adjustment

If the door *stops* on the obstruction, it is not traveling far enough in the down direction.

- Increase the DOWN limit by turning the DOWN limit adjustment screw counterclockwise 1/4 turn.
- Repeat the test.

On a sectional door, make sure limit adjustments do not force the door arm beyond a straight up and down position. See the illustration on page 26.

- When the door reverses on the one-inch board, remove the obstruction and run the opener through 3 or 4 complete travel cycles to test adjustment.

If the door will not reverse after repeated adjustment attempts, call for professional garage door service.

Important Safety Check

Repeat Adjustment Steps 1-4 after:

- Each adjustment of door arm length, force controls or limit controls.
- Any repair to or adjustment of the garage door (including springs and hardware).
- Any repair to or buckling of the garage floor.
- Any repair to or adjustment of the opener.



WARNING

Failure to test and adjust the safety reverse system may result in serious injury or death to persons trapped by a closing garage door. Repeat this test once a month and adjust as needed.

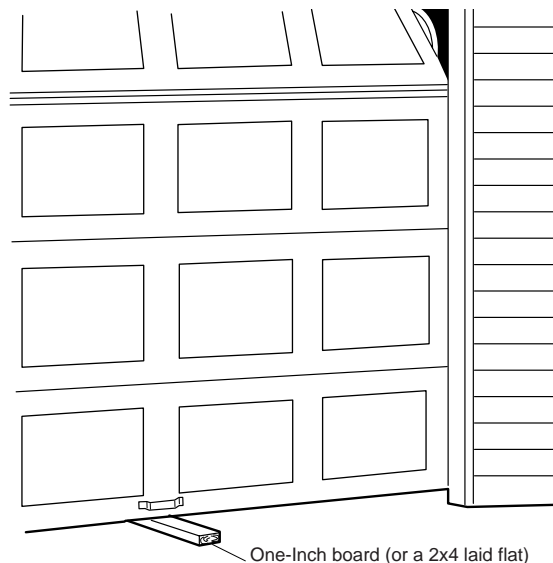

IMPORTANT SAFETY INSTRUCTIONS



WARNING



WARNING

To reduce the risk of severe injury or death to persons:

1. READ AND FOLLOW ALL INSTRUCTIONS.
2. Do not permit children either to operate or to play with the opener. Keep remote control in a location inaccessible to children.
3. Operate opener only when the door is in full view and free from any obstruction. Keep the door in sight until it is completely closed. **NO ONE SHOULD CROSS THE PATH OF THE MOVING DOOR.**
4. Check safety reversal system monthly. See page 30. The garage door **MUST** reverse on contact with a one inch object (or a 2x4 board laid flat) placed on the floor. If an adjustment is made to one of the controls (either force or limits of travel), the other control may need to be adjusted also, and the safety reversal system *must* be checked. *Failure to properly adjust the opener may result in severe injury or death.*
5. If possible, use the manual release only when the door is in a closed position. Caution should be taken whenever the disconnect cord is actuated with the door open. *Weak or broken springs may cause the door to fall rapidly, causing injury or death to persons.*
6. **KEEP GARAGE DOORS PROPERLY BALANCED.** See page 3. *An improperly balanced door may not reverse when required, and could result in severe injury or death.* Repairs to cables, spring assemblies and other hardware must be made by a professional garage door person.
7. Disconnect the electric power to the garage door opener before making any repairs or removing the covers.

SAVE THESE INSTRUCTIONS

Care of Your Opener

Force and Limit Adjustment Controls

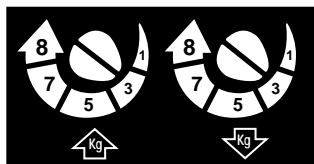

FORCE CONTROLS

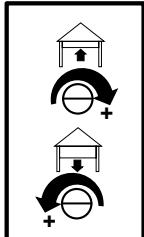

LIMIT CONTROLS

Weather conditions may cause some minor changes in door operation requiring some re-adjustments, particularly during the first year of operation.

Pages 28 and 29 refer to the limit and force adjustments. Only a screwdriver is required. Follow the instructions carefully.

Repeat the safety reverse test (page 30) after any adjustment of limits or force.

The remote control transmitter

The opener must learn the code of any new remote control. Page 33 explains how to program your receiver and how to erase all codes if required. Self service of your receiver and remote controls is not recommended. If service is needed, call the toll-free number listed on the back page.

The remote control battery

The lithium battery should produce power for up to 5 years. To replace battery, pry open case with visor clip or screwdriver, as shown. Insert battery *positive side up*.

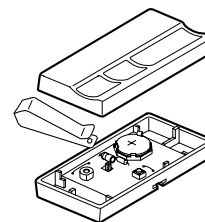

Dispose of your old battery properly.



WARNING

Keep batteries away from small children. If swallowed, promptly notify doctor.

Maintenance Schedule

Once a Month

Manually operate door. If it is unbalanced or binding, call for professional garage door service.

Check to be sure door opens & closes fully. Adjust limits and/or force if necessary. (See pages 28 & 29.)

Repeat the safety reverse test. Make any necessary adjustments (See page 30).

Once a Year

Oil door rollers, bearings and hinges. The opener does not require additional lubrication. Do not grease the door tracks.

Operation of Your Opener

Activate the opener with any of the following:

- **The Remote Control Transmitter.** Hold the large push button down until the door starts to move.
- **The Door Control.** Hold push bar down until the door starts to move.
- **The Outside Keylock or Keyless Entry.** (See Accessories)

When the opener is activated with the safety reversing sensor installed and correctly aligned:

1. If open, the door will close. If closed, it will open.
2. If closing, the door will reverse.
3. If opening, the door will stop (allowing space for entry and exit of pets and for fresh air).
4. If the door has been stopped in a partially open position, it will close.
5. If obstructed while closing, the door will reverse.
6. If obstructed while opening, the door will stop.
7. The garage door will reverse in the closing cycle, and the opener lights will blink for 5 seconds, when the invisible beam is broken. If fully open, the door will not close when the beam is broken. The sensor has no effect in the opening cycle.

If the sensor is not installed, or is not aligned correctly, the door won't close from any remote transmitter. However, you can close the door with the Door Control, the Outside Keylock, or Keyless Entry if you activate them *until down travel is complete*. If you release them too soon, the door will *reverse*.

The Opener Lights will turn on under the following conditions: When the opener is initially plugged in; when the power is interrupted; when the opener is activated. It will turn off automatically after 4-1/2 minutes or provide constant light when the Light feature on the Multi-Function Door Control is activated. Bulb size is 100 watts maximum.

Lights will also turn on when someone walks through the open garage door. With a *Multi-Function Door Control*, this feature may be turned off as follows: With the opener lights off, press and hold the light button for 10 seconds, until the light goes on and off again. To restore this feature, start with the opener lights on, then press and hold the light button for 10 seconds.



WARNING

*Weak or broken springs could allow an open door to fall (either rapidly or unexpectedly), resulting in serious injury, death or property damage. If possible, use the manual release rope and handle **only** when the door is fully closed.*

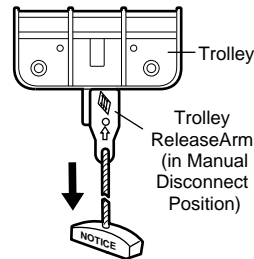

Lockout position (Manual disconnect)

To open the door manually: The door should be fully closed if possible. Pull down on the manual release handle (so that the trolley release arm snaps into a vertical position) and lift the door manually. The **lockout feature** prevents the trolley from reconnecting automatically, and the door can be raised and lowered manually as often as necessary.

To reengage the trolley:

Pull the manual release handle toward the opener at a 45° degree angle so that the trolley release arm is horizontal. The trolley will reconnect on the next UP or DOWN operation, either manually or by pressing the Door Control push bar.

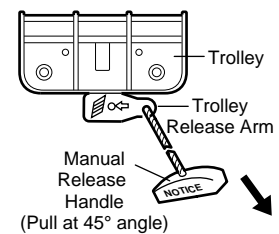

To reconnect

Operation of the Multi-Function Door Control

(See additional programming features, next page.)

Door Control Push Bar: Press the white square to open or close the door. Press again to *reverse* the door during the closing cycle or to *stop* the door while it's opening.

Light Feature: Press the Light button. If the opener light is *off*, it will turn *on*. If the opener light is *on*, (even in the 4-1/2 minute automatic cycle) it will turn *off*.

But if you use the Light button to turn the lights *on* and then activate the opener, the lights will turn *off* after 4-1/2 minutes.

The 4-1/2 minutes interval can be changed to 1-1/2, 2-1/2, or 3-1/2 minutes as follows: Press and hold the Lock button until the light blinks (about 10 seconds). A single blink indicates that the timer is reset to 1-1/2 minutes. Repeat the procedure and the light will blink twice, resetting the timer to 2-1/2 minutes. Repeat again for a 3-1/2 minute interval, etc., up to a maximum of four blinks and 4-1/2 minutes.

The Light button will not control the opener lights when the door is in motion.

Lock Feature: The Lock feature is designed to prevent operation of the door from remote controls. However, the door will *open and close* from the Door Control push bar, the Outside Keylock and the Keyless Entry Accessories.

To Activate: Press and hold the Lock button for 2 seconds. The push bar light will flash as long as the Lock feature is *on*.

To turn off: Press and hold the Lock button again for 2 seconds. The push bar light will stop flashing. Normal operation will resume. The Lock feature will also turn off whenever the "Smart" button on the opener panel is activated.

Receiver and Remote Control Programming

SECURITY+

NOTICE: To comply with FCC rules, adjustment or modification of this receiver and/or transmitter are prohibited, except for changing the code setting or replacing the transmitter battery. THERE ARE NO OTHER USER SERVICEABLE PARTS.



WARNING

Children operating or playing with a garage door opener can injure themselves or others. *The garage door could close and cause serious injury or death.* Do not allow children to operate the door control(s) or remote control transmitter(s).

A moving garage door could injure or kill someone under it. Activate the opener only when you can see the door clearly, it is free of obstructions, and is properly adjusted.

Your garage door opener receiver and remote control have been pre-set at the factory. The door will open when you press the LARGE remote control push button. The code between the remote control and the receiver changes with each use, randomly accessing over 100 billion new codes.

Your SECURITY+ opener will operate with:

- several SECURITY+ remote controls utilizing up to 8 functions.
- one SECURITY+ Keyless Entry System.

Follow the instructions below to program your opener to match any additional remotes you may purchase. See Accessories on page 38.

To Add A Remote Control

1. *With the door closed*, press and *hold* a button on the remote to be programmed. See Figure 1.
2. Press and release the Smart (learn) button on the opener panel, Figure 2. The indicator light on the panel will begin to blink and the opener light will flash once.
3. Release the remote push button.

Test by pressing the remote push button.

To Add A Remote Control Using the Door Control

1. *With the door closed*, press and *hold* a remote control push button. See Figure 1.
2. Press and hold the Light button on the door control.
3. Press and hold the door control push bar.
4. After the opener lights flash, release all buttons.

Test by pressing the remote push button.

To Erase All Remote Control Codes

Press and hold the Smart button on the opener panel for 6 seconds. The indicator light will turn on. Release the Smart button when it turns off. All codes are now erased from the opener. Then follow the steps above to re-program each remote control.

Figure 1

SECURITY+ Remote Control

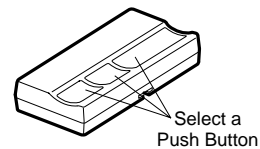
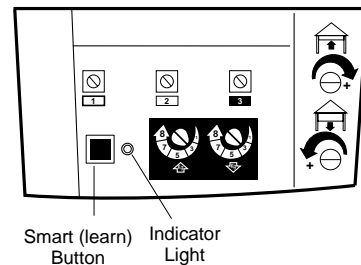

Figure 2

SECURITY+ Garage Door Opener



To Control the Opener Lights

With SECURITY+ transmitters, a remote push button can be programmed to operate the opener lights without opening the door.

1. *With the door closed*, press and hold the remote button that you want to control the light.
2. Press and hold the Light button on the door control.
3. Press and hold the Lock button on the door control.
4. After the opener lights flash, release all buttons.

Test by pressing the remote push button. The opener lights should turn on or off but the door should not move.

Code programming instructions are also located on the opener panel.

Having a Problem?

Situation

Probable Cause & Solution

The opener doesn't operate from either the door control or the remote control:

1. Does the opener have electric power? Plug a lamp into the outlet. If it doesn't light, check the fuse box or the circuit breaker. (Some outlets are controlled by a wall switch.)
2. Have you disabled all door locks? Review installation instruction warnings on Page 11.
3. Is there a build-up of ice or snow under the door? The door may be frozen to the ground. Remove any restriction.
4. The garage door spring may be broken. Have it replaced.
5. Repeated operation may have tripped the overload protector in the motor. Wait 15 minutes. Try again.

Opener operates from the remote control, but not from the door control:

1. Is the door control push bar lit? If not, remove the bell wire from the opener terminal screws. Short the red and white terminals by touching both terminals at the same time with a piece of wire. If the opener runs, check for a faulty wire connection at the door control, a short under the staples, or a broken wire.
2. Are the wiring connections correct? Review Installation Step 7, page 21.

The door operates from the door control, but not from the remote control:

1. Is the door push bar flashing? If the Lock button is on, turn it *off*.
2. Your opener needs to re-learn a remote control code. Refer to instructions on the opener panel.
3. Program the receiver to match the remote control code.
4. Repeat the receiver programming procedure with all remote controls.

The remote control has short range:

1. Change the location of the remote control in your car.
2. Check to be sure the antenna on the right side panel of opener extends fully.
3. Some installations may have shorter range due to a metal door, foil backed insulation, or metal garage siding.

Opener noise is disturbing in living quarters of home:

If operational noise is a problem because of proximity of the opener to the living quarters, the Vibration Isolator Kit 41A3263 can be installed. This kit was designed to minimize vibration to the house and is easy to install.

The garage door opens and closes by itself:

1. Be sure that all remote control push buttons are off.
2. Remove the bell wire from the door control terminals and operate from the remote control only. If this solves the problem, the door control is faulty (replace), or there is an intermittent short on the wire between the door control and the opener.
3. Clear memory and reprogram all remote controls.

The door doesn't open completely:

1. If the door has been working properly but now doesn't open all the way, increase the *up force*. See page 29.
2. Is something obstructing the door? Remove the obstruction or repair the door.
3. If door opens at least 5 feet, the travel limits may need to be increased. One turn equals 2 inches of travel. See page 28.

Repeat the safety reverse test after the adjustment is complete.

The door stops but doesn't close completely:

Review the travel limits adjustment procedures on page 28.

Repeat the safety reverse test after any adjustment of door arm length, close force or down limit.

Having a Problem? *(continued)*

Situation

Probable Cause & Solution

The door opens but won't close:

1. If the opener lights blink, check the safety reversing sensor. See page 22.
 2. If the opener lights do not blink and it is a new installation, check the down force. See Adjustment Step 2, page 29. For an existing installation, see below.
Repeat the safety reverse test after the adjustment is complete.
-

The door reverses for no apparent reason and opener lights don't blink:

1. Is something obstructing the door? Pull the manual release handle. Operate the door manually. If it is unbalanced or binding, call for professional garage door service.
 2. Clear any ice or snow from the garage floor area where the door closes.
 3. Review the force adjustment procedures on page 29.
 4. If door reverses in the *fully closed* position, decrease the travel limits (page 28).
Repeat the safety reverse test after adjustments to force or travel limits. The need for occasional adjustment of the force and limit settings is normal. Weather conditions in particular can affect door travel.
-

The door reverses for no apparent reason and opener lights blink for 5 seconds after reversing:

Check the safety reversing sensor. Remove any obstruction or align the receiving eye. See page 22.

The opener lights...

don't turn on:

Replace the light bulb(s) (100 watts maximum). Use a *standard neck* garage door opener bulb if regular bulb burns out.

don't turn off:

Is the Light feature *on*? Turn it *off*.

The opener strains or maximum force is needed to operate door:

The door may be out of balance or the springs are broken. **Close the door** and use the manual release handle to disconnect the trolley. Open and close the door manually. A properly balanced door will stay in any point of travel while being supported entirely by its springs. If it does not, disconnect the opener and call for professional garage door service. **Do not increase the force to operate the opener.**

The opener motor hums briefly, then won't work:

1. The garage door springs are broken. See above.
 2. If the problem occurs on the first operation of the opener, door may be locked. *Disable the door lock.*
Repeat the safety reverse test after the adjustment is complete.
-

The opener won't operate due to power failure:

1. Use the manual release handle to disconnect the trolley. The door can be opened and closed manually. When power is restored, press the Door Control push bar and trolley will automatically reconnect (unless trolley is in lockout position.) See page 32.
2. The Outside Quick Release accessory (for use on garages with no service door) disconnects the trolley from outside the garage in case of power failure.

Repair Parts

Rail Assembly Parts

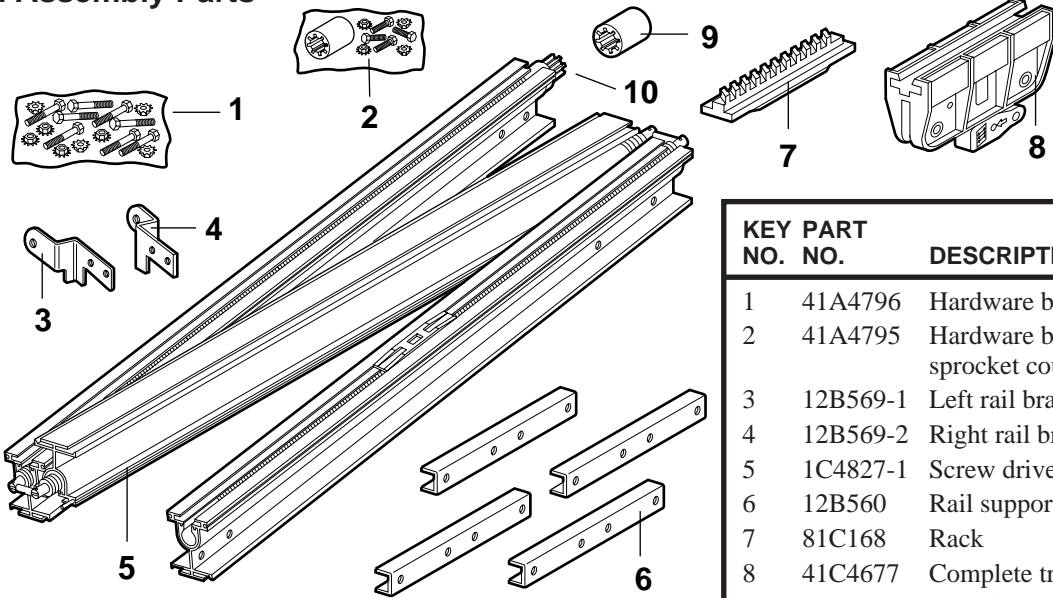

KEY PART NO.	PART NO.	DESCRIPTION
1	41A4796	Hardware bag
2	41A4795	Hardware bag (includes sprocket coupling)
3	12B569-1	Left rail bracket
4	12B569-2	Right rail bracket
5	1C4827-1	Screw drive rail assembly
6	12B560	Rail support brace
7	81C168	Rack
8	41C4677	Complete trolley assembly
9	25A18	Sprocket coupling
10	41A4836	Drive sprocket kit

Installation Parts

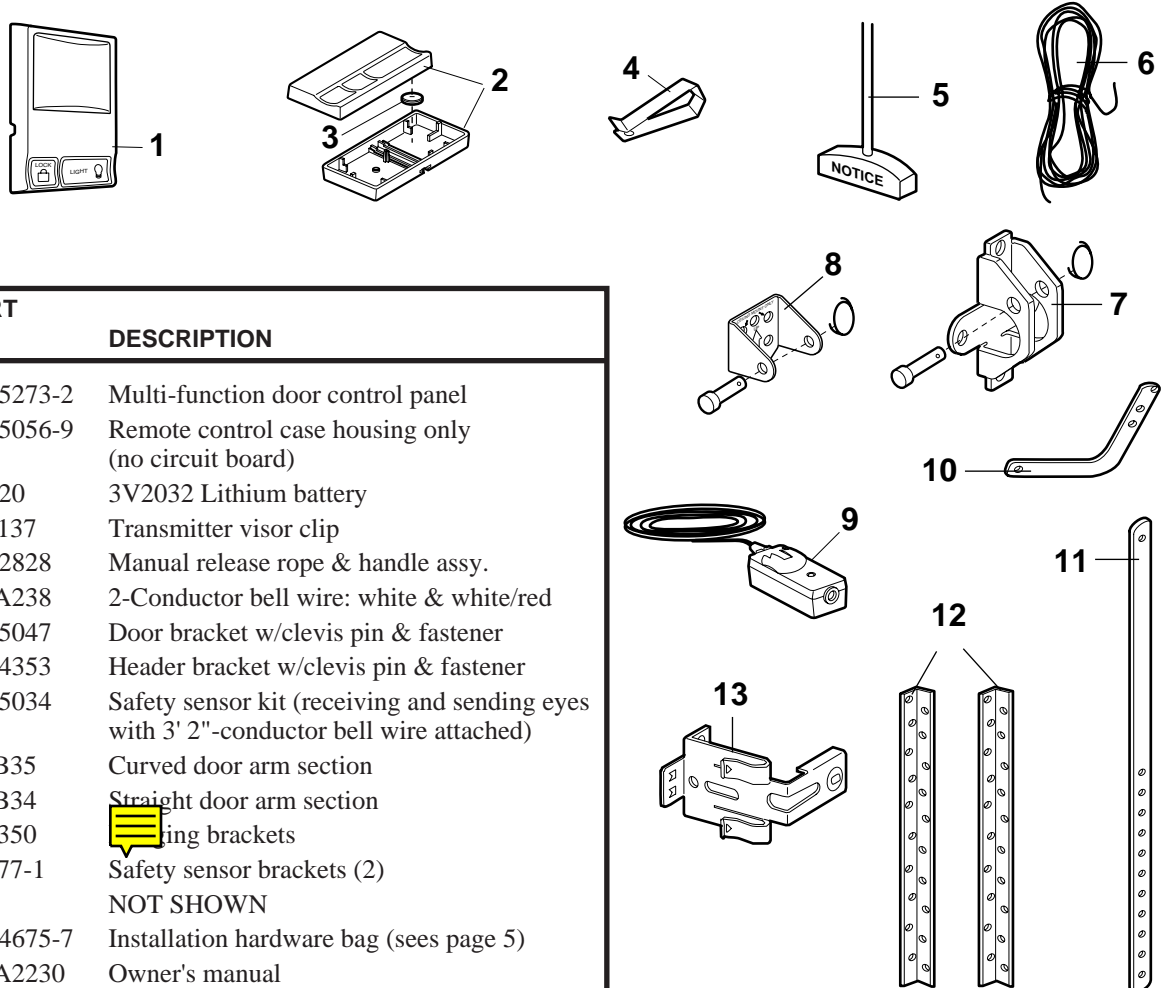

KEY NO.	PART NO.	DESCRIPTION
1	41A5273-2	Multi-function door control panel
2	41A5056-9	Remote control case housing only (no circuit board)
3	10A20	3V2032 Lithium battery
4	29B137	Transmitter visor clip
5	41A2828	Manual release rope & handle assy.
6	217A238	2-Conductor bell wire: white & white/red
7	41A5047	Door bracket w/clevis pin & fastener
8	41A4353	Header bracket w/clevis pin & fastener
9	41A5034	Safety sensor kit (receiving and sending eyes with 3' 2"-conductor bell wire attached)
10	178B35	Curved door arm section
11	178B34	Straight door arm section
12	12B350	Mounting brackets
13	2B477-1	Safety sensor brackets (2)
		NOT SHOWN
	41A4675-7	Installation hardware bag (sees page 5)
	114A2230	Owner's manual



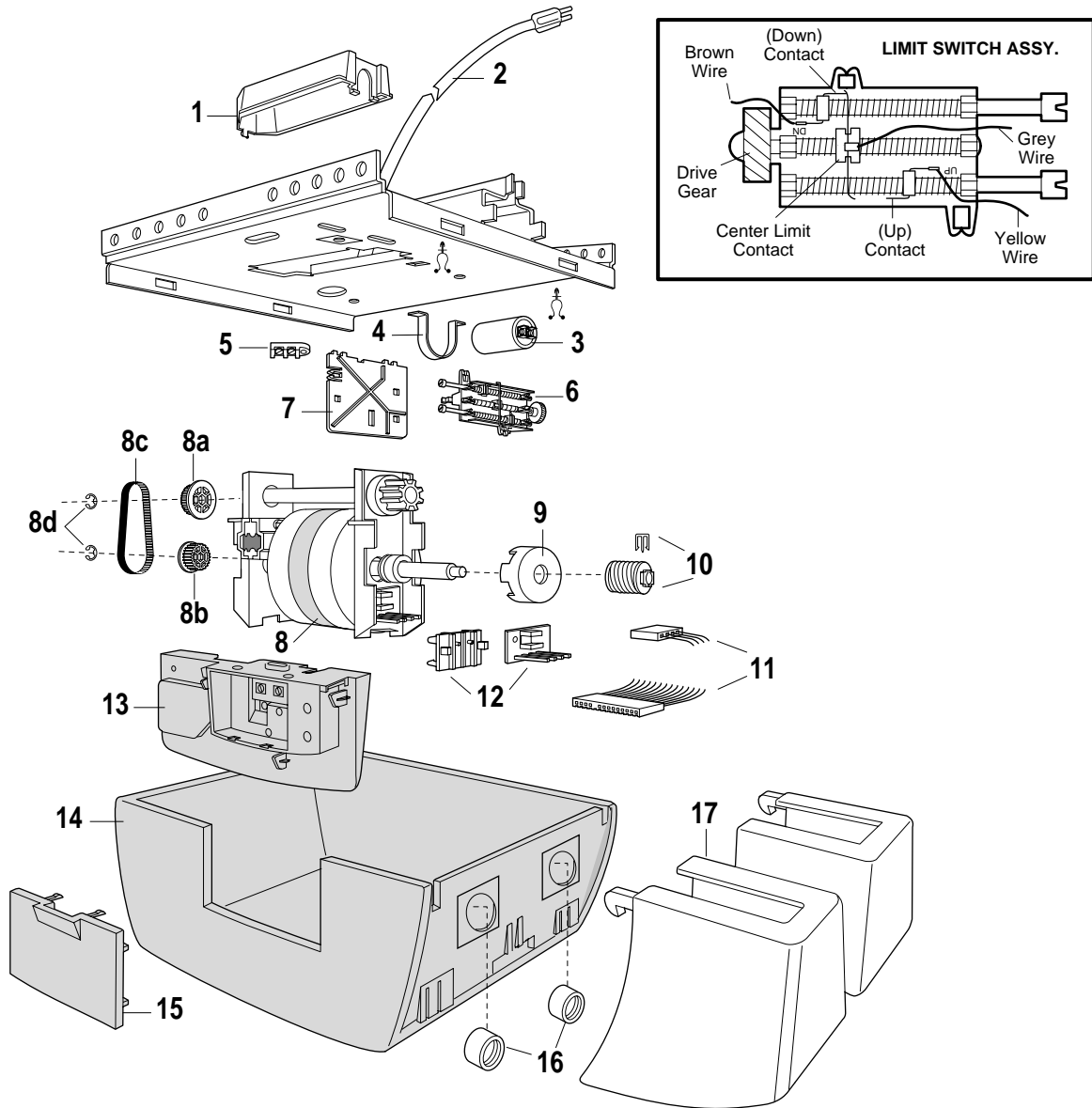

Repair Parts

Opener Assembly Parts

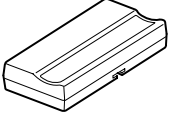

KEY NO.	PART NO.	DESCRIPTION	KEY NO.	PART NO.	DESCRIPTION
1	31D426	Drive shaft cover	8d	158A69	Retainer Ring
2	41B4245	Line cord	9	41A4843	Interrupter cup
3	30B363	Capacitor – 1/2 HP	10	41A4837	Worm gear and retainer
4	12A373	Capacitor bracket	11	41C4669	Wire harness assembly
5	41A3150	Terminal block w/screws	12	41C4672	RPM sensor assembly
6	41D4671	Limit switch assembly	13	41D4674-14E	Receiver logic board assembly
7	12D554	Limit switch bracket	14	41D4977-5	Cover
8	41D4759	Complete Motor Drive Assy., with	15	1C4840-2	Control Center access door
8a	144B41	22T Pulley	16	175C123	Light socket
8b	144B42	28T Pulley	17	108D47	Light lens
8c	20C14	Drive Belt			

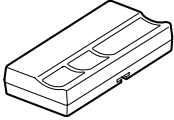
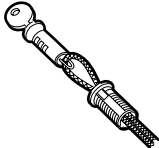
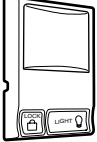
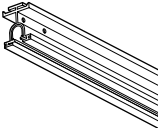
Accessories Available For Your Opener

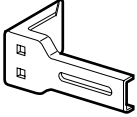
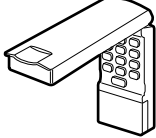
<p>950CB</p> 	<p>SECURITY+ Single-Function Remote Control: Includes visor clip.</p>	<p>956CB</p> 	<p>SECURITY+ Multi-Function Mini Remote Control: With key ring and Velcro fastening strip.</p>
<p>953CB</p> 	<p>SECURITY+ Multi-Function Remote Control: Includes visor clip.</p>	<p>7702CB</p> 	<p>Outside Quick Release: <i>Required</i> for a garage with NO access door. Enables homeowner to open garage door manually from outside by disengaging trolley.</p>
<p>945CB</p> 	<p>Multi-Function Door Control Panel: Provides a Lock Feature which prevents operation of garage door opener from portable remotes and a Light Feature for constant light.</p>	<p>7706CB</p> 	<p>8 foot Rail Extension Kit: To allow an 8 foot door to open fully.</p>
<p>935CB</p> 	<p>Motion Detecting Control Panel: Multi-function door control with motion sensor that automatically turns opener lights on for 5 minutes when it detects a person entering the garage. Sensor can be easily deactivated when desired.</p>	<p>41A5281</p> 	<p>Extension Brackets: (Optional) For safety sensor installation onto the wall or floor. To order call: 1-800-528-9131</p>
<p>940CB</p> 	<p>SECURITY+ Keyless Entry: Enables homeowner to operate garage door opener from outside by entering a password on a specially designed keyboard. Also can add a temporary password for visitors or service persons. This temporary password can be limited to a programmable number of hours or entries.</p>		

To Add the Keyless Entry

We recommend that you program your password before you install the Keyless Entry. You will not need assistance, and you can test the reception at the mounting location before installation.

If you have a Multi-Function door control:

1. *With the door closed*, press the four digit password desired, then press and hold Enter.
2. Press and hold the light button on the door control.
3. Press and hold the door control push bar.
4. After the opener lights flash, release all buttons.

If you do not have a Multi-Function door control:

1. Choose a 4-digit password using numbers from 0 to 9 (a number can be used more than once, for example, 4, 0, 4, 1).
2. Press the four buttons for the password, then press and *hold* the Enter button. The indicator light on the door opener panel will blink.
3. Press and release the “Smart” (learn) button on the opener panel. After the opener lights flash, release the Enter button.

Test by pressing the password, then press Enter. The door should begin to move.

Setting a Temporary Password

In addition to your personal entry password which works at all times, a 4-digit temporary password can be added for the convenience of visitors or service persons. This allows authorized persons a way to gain temporary access.

After a programmed number of hours or number of accesses, this temporary password expires and will no longer open the door. The temporary password can be used to *close* the door even after it has expired. To set a temporary password:

1. Press the four buttons for your personal entry password (not the last temporary password), then press and hold the * button.
The opener light will blink three times. Release the button.
2. Press the temporary 4-digit password you have chosen, then press Enter.
The opener light will blink four times.
3. To set the number of *hours* this temporary password will work, press the number of hours (up to 255), then press *.

OR

3. To set the number of *times* this temporary password will work, press the number of times (up to 255), then press #.
The opener light will blink once when the temporary password has been learned.

Test by pressing the four buttons for the temporary password, then press Enter. The door should move. If the temporary password was set to a certain number of openings, remember that the test has used up one opening.

To clear the temporary password, repeat steps 1-3, setting the number of hours or times to 0 in step 3.

Index

Access Door/Outside Quick Release Accessory	6, 7, 35, 36
Electrical Safety Warnings	2, 22, 31
Garage Door	
Testing for balance, binding and sticking.....	3, 28, 31
Determining high point of travel:	
Sectional door.....	12
One-piece door	13
Disabling existing locks	3, 11
Force controls	
Adjustment procedures.....	29
Problems that might require force adjustments.....	34, 35
Safety warnings.....	29, 31
Door hardware.....	3, 11, 12, 31, 32
Maintenance	11, 28-31
Reinforcement requirements	4, 24, 25
Removing of all ropes	3, 11
Possible door damage.....	3, 19, 24
Travel limits	
Adjustment procedures.....	27, 28
Problems that might require limit adjustments	34, 35
Safety warnings.....	28, 31
Manual Release Rope & Handle	
Lockout feature	32
Manual disconnect.....	32, 35
Safety warnings	11, 23, 31, 32
Opener Terminals	
Door control connections	21
Safety reversing sensor connections.....	21, 22
Protector System®	16, 30
Receiver & Remote Controls	
Programming the receiver	33
Erasing all codes.....	33
Safety warning.....	33
Problems with remote control transmitter operation.....	34
Safety Reverse Test Procedure	30
Testing required.....	11, 30, 34, 35
Safety reverse system problems	
Securing header bracket to wall	12
Adjusting travel limits.....	28
Applying excessive force on the door	29
Buckling or uneven floor.....	4, 5
Safety Warnings	2, 3, 11, 12, 16, 19, 20, 21, 22, 23, 24, 28, 29, 30, 31, 32, 33
User Instruction Label for Garage Wall	11, 21
Vibration noise (isolator kit)	34

CHAMBERLAIN SERVICE IS ON CALL

OUR LARGE SERVICE ORGANIZATION
SPANS AMERICA

INSTALLATION AND SERVICE INFORMATION IS AS
NEAR AS YOUR TELEPHONE SIX DAYS A WEEK.
SIMPLY DIAL OUR TOLL FREE NUMBER:

1-800-528-9131

HOURS: (Central Standard Time)
6:00 A.M. TO 7:00 P.M. Monday through Friday
8:00 A.M. TO 6:00 P.M. Saturday

For professional installation, parts and service,
contact your local CHAMBERLAIN dealer. Look for him
in the Yellow Pages, or call our Service number for a list
of dealers in your area.

HOW TO ORDER REPAIR PARTS

Selling prices will be furnished on request or parts will
be shipped at prevailing prices and you will be billed
accordingly.

WHEN ORDERING REPAIR PARTS, ALWAYS GIVE
THE FOLLOWING INFORMATION:

- PART NUMBER
- PART NAME
- MODEL NUMBER

ADDRESS ORDERS TO:

THE CHAMBERLAIN GROUP, INC.
Parts and Service Department
2301 N. Forbes Boulevard, Suite 104
Tucson, Arizona 85745

SERVICE INFORMATION TOLL FREE NUMBER:

1-800-528-9131

CHAMBERLAIN GARAGE DOOR OPENER ONE-YEAR LIMITED WARRANTY

The Chamberlain Group, Inc. ("Seller") warrants to the first retail purchaser of this product, for the residence in which this product is originally installed, that it will be free from any defect in materials and/or workmanship for a period of one year from the date of purchase. Additionally, the motor is warranted for the lifetime of the product. The product must be used in complete accordance with Chamberlain's instructions for installation, operation, and care. **The proper operation of this product is dependent on your compliance with the Owner's Manual instructions regarding installation, operation, maintenance and testing. Failure to comply strictly with those instructions will void this warranty in its entirety. Please note that the safety reverse system, in order to operate properly with your garage door, must be adjusted and periodically tested in accordance with the Owner's Manual.**

If, during the limited warranty period, it appears as though this product contains a defect which is covered by this limited warranty, **call our toll free service number, before dismantling this product, at 1-800-528-9131.** Then send this product, pre-paid and insured, to our service center for warranty repair. You will be advised of shipping instructions when you call the toll free service number. Please include a brief description of the problem and a dated proof-of-purchase receipt with any product that is returned for warranty repair.

Products returned to Seller for warranty repair, which upon receipt by Seller are confirmed to be defective and covered by this limited warranty, will be repaired or replaced (at Seller's sole option) at no cost to you and returned pre-paid. Defective parts will be repaired or replaced with new or factory-rebuilt parts at Seller's sole option.

THIS LIMITED WARRANTY IS IN LIEU OF ANY OTHER WARRANTIES, EXPRESS OR IMPLIED, INCLUDING ANY IMPLIED WARRANTY OF MERCHANTABILITY OR FITNESS FOR A PARTICULAR PURPOSE, OR OTHERWISE, AND OF ANY OTHER OBLIGATIONS OR LIABILITY ON SELLER'S PART. THIS LIMITED WARRANTY DOES NOT COVER NON-DEFECT DAMAGE, DAMAGE CAUSED BY IMPROPER INSTALLATION, OPERATION OR CARE (INCLUDING, BUT NOT LIMITED TO ABUSE, MISUSE, FAILURE TO PROVIDE REASONABLE AND NECESSARY MAINTENANCE, OR ANY ALTERATIONS TO THIS PRODUCT), LABOR CHARGES FOR DISMANTLING OR REINSTALLING A REPAIRED OR REPLACED UNIT, REPLACEMENT OF BATTERIES AND LIGHT BULBS, OR UNITS INSTALLED FOR NON-RESIDENTIAL USE.

THIS LIMITED WARRANTY DOES NOT COVER ANY PROBLEMS WITH, OR RELATING TO, THE GARAGE DOOR OR GARAGE DOOR HARDWARE, INCLUDING BUT NOT LIMITED TO THE DOOR SPRINGS, DOOR ROLLERS, DOOR ALIGNMENT AND HINGES. ANY SERVICE CALL THAT DETERMINES THE PROBLEM HAS BEEN CAUSED BY ANY OF THESE ITEMS COULD RESULT IN A FEE TO YOU.

UNDER NO CIRCUMSTANCES SHALL SELLER BE LIABLE FOR CONSEQUENTIAL, INCIDENTAL OR SPECIAL DAMAGES ARISING IN CONNECTION WITH THE USE OF, OR INABILITY TO USE, THIS PRODUCT. IN NO EVENT SHALL SELLER'S LIABILITY FOR BREACH OF WARRANTY, BREACH OF CONTRACT, NEGLIGENCE OR STRICT LIABILITY EXCEED THE COST OF THE PRODUCT COVERED HEREBY. NO PERSON IS AUTHORIZED TO ASSUME FOR US ANY OTHER LIABILITY IN CONNECTION WITH THE SALE OF THIS PRODUCT.

Some states do not allow the exclusion or limitation of consequential, incidental or special damages, so the above limitation or exclusion may not apply to you. This limited warranty gives you specific legal rights, and you may also have other rights which vary from state to state.

LIMITED WARRANTY ON MOTOR

The motor is fully warranted for the lifetime of the product to the first-time purchaser.