

CHAMBERLAIN[®] SECURITY[™]+

The Chamberlain Group, Inc.
845 Larch Avenue
Elmhurst, Illinois 60126-1196
www.chamberlaingroup.com



GARAGE DOOR OPENER

Series 8200
1/2 HP

For Residential Use Only

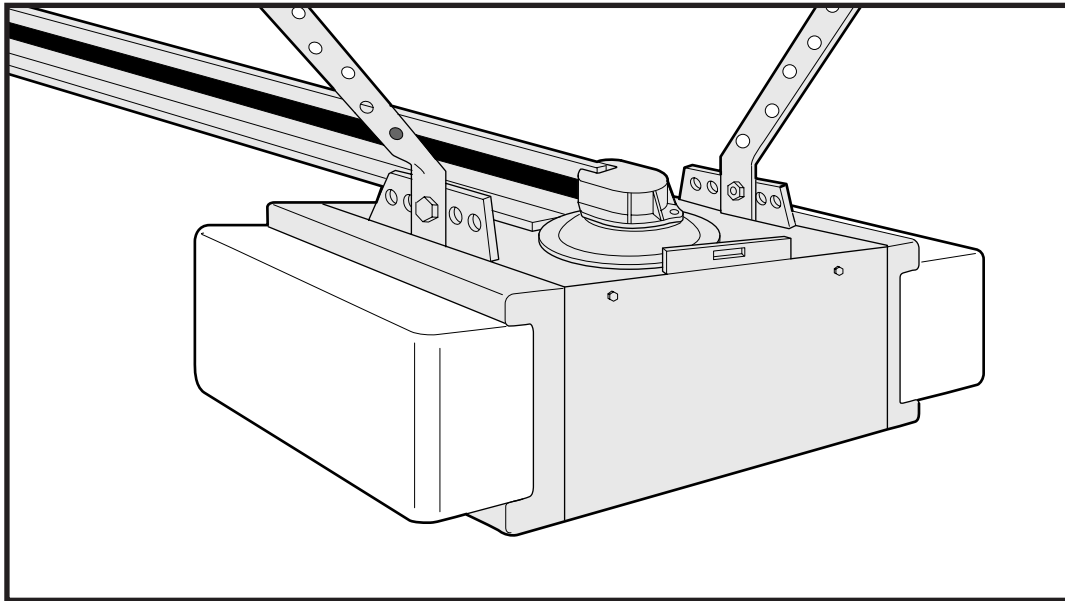

Owner's Manual

- Please read this manual and the enclosed safety materials carefully!
- Fasten the manual near the garage door after installation.
- The door **WILL NOT CLOSE** unless the Protector System[®] is connected and properly aligned.
- Periodic checks of the opener are required to ensure safe operation.
- The model number label is located on the left side panel of your opener.

TABLE OF CONTENTS

<i>Introduction</i>	<i>Pages 2-7</i>	<i>Adjustment</i>	<i>Pages 28-30</i>
Safety symbol and signal word review.....	2	Adjust the travel limits.....	28
Preparing your garage door.....	3	Adjust the force.....	29
Tools needed.....	3	Test the safety reversal system.....	30
Planning.....	4-5	Test the Protector System®.....	30
Carton inventory.....	6	<i>Operation</i>	<i>Pages 31-34</i>
Hardware inventory.....	7	Operation safety instructions.....	31
<i>Assembly</i>	<i>Pages 8-11</i>	Using your garage door opener.....	31
Assemble T-rail & attach the belt pulley bracket.....	8	Using the wall-mounted door control.....	32
Install the trolley.....	9	To open the door manually.....	32
Fasten T-rail to motor unit.....	9	Care of your garage door opener.....	33
Install the belt and set the tension.....	10	Having a problem?.....	34
Attach the belt cap retainer.....	11	<i>Programming</i>	<i>Pages 35-36</i>
<i>Installation</i>	<i>Pages 11-27</i>	To add a hand-held remote control.....	35
Installation safety instructions.....	11	To erase all codes.....	35
Determine the header bracket location.....	12-13	Multi-function remotes.....	35
Install the header bracket.....	14	To add or change a Keyless Entry PIN.....	36
Attach the T-rail to the header bracket.....	15	<i>Repair Parts</i>	<i>Pages 37-38</i>
Position the opener.....	16	Rail assembly parts.....	37
Hang the opener.....	17	Installation parts.....	37
Install the door control.....	18	Motor unit assembly parts.....	38
Install the lights and lens.....	19	<i>Accessories</i>	39
Attach the emergency release rope and handle.....	19	<i>Repair Parts and Service</i>	40
Electrical requirements.....	20	<i>Warranty</i>	40
Install the Protector System®.....	21-23		
Fasten the door bracket.....	24-25		
Connect the door arm to the trolley.....	26-27		

INTRODUCTION

Safety Symbol and Signal Word Review

This garage door opener has been designed and tested to offer safe service provided it is installed, operated, maintained and tested in strict accordance with the instructions and warnings contained in this manual.

 **WARNING**

Mechanical

 **WARNING**

Electrical

CAUTION

When you see these Safety Symbols and Signal Words on the following pages, they will alert you to the possibility of **serious injury or death** if you do not comply with the warnings that accompany them. The hazard may come from something mechanical or from electric shock. Read the warnings carefully.

When you see this Signal Word on the following pages, it will alert you to the possibility of damage to your garage door and/or the garage door opener if you do not comply with the cautionary statements that accompany it. Read them carefully.

Preparing your garage door

Before you begin:

- Disable locks.
- Remove any ropes connected to garage door.
- **Complete the following test** to make sure your garage door is balanced and is not sticking or binding:
 1. Lift the door about halfway as shown. Release the door. If balanced, it should stay in place, supported entirely by its springs.
 2. Raise and lower the door to see if there is any binding or sticking.

If your door binds, sticks, or is out of balance, call a trained door systems technician.

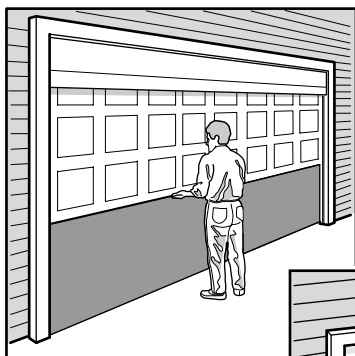

Sectional Door

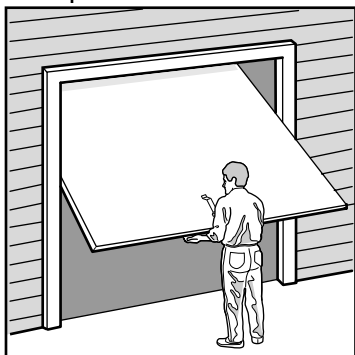

One-Piece Door

⚠ WARNING

To prevent possible **SERIOUS INJURY OR DEATH**:

- **ALWAYS** call a trained door systems technician if garage door binds, sticks, or is out of balance. An unbalanced garage door may not reverse when required.
- **NEVER** try to loosen, move or adjust garage door, door springs, cables, pulleys, brackets or their hardware, all of which are under **EXTREME** tension.
- Disable **ALL** locks and remove **ALL** ropes connected to garage door **BEFORE** installing and operating garage door opener to avoid entanglement.

CAUTION

To prevent damage to garage door and opener:

- **ALWAYS** disable locks before installing and operating the opener.
- **ONLY** operate garage door opener at 120V, 60 Hz to avoid malfunction and damage.

Tools needed

During assembly, installation and adjustment of the opener, instructions will call for hand tools as illustrated below.

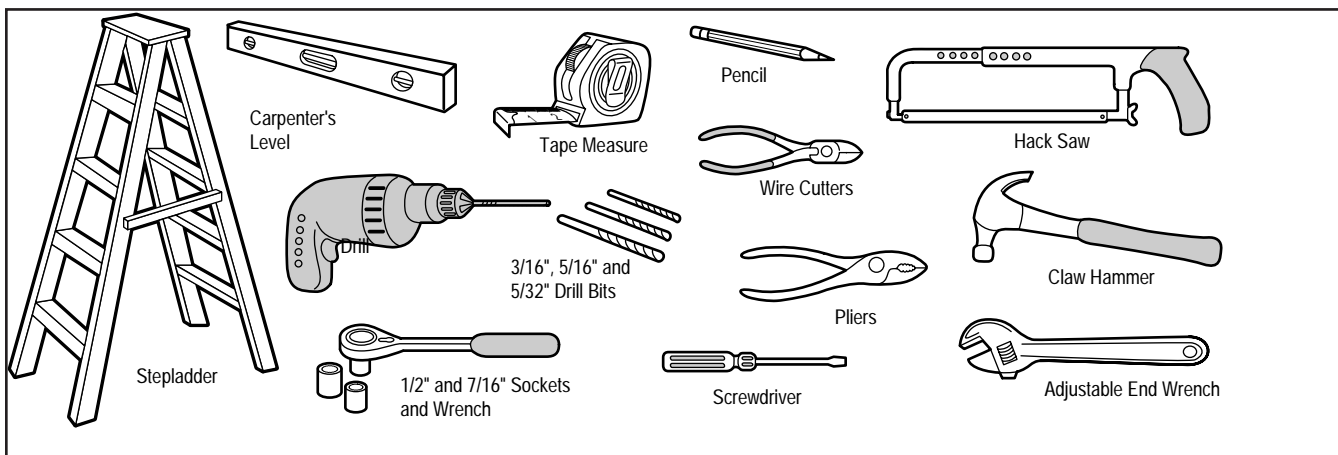

Planning

Identify the type and height of your garage door. Survey your garage area to see if any of the conditions below apply to your installation. Additional materials may be required. You may find it helpful to refer back to this page and the accompanying illustrations as you proceed with the installation of your opener.

Depending on your requirements, there are several installation steps which may call for materials or hardware not included in the carton.

- Installation Step 1 – Look at the wall or ceiling above the garage door. The header bracket must be securely fastened to structural supports.
- Installation Step 5 – Do you have a finished ceiling in your garage? If so, a support bracket and additional fastening hardware may be required.
- Installation Step 10 – Depending upon garage construction, extension brackets or wood blocks may be needed to install sensors.
- Installation Step 10 – Alternate floor mounting of the safety reversing sensor will require hardware not provided.

- Do you have an access door in addition to the garage door? If not, Model 7702C Outside Quick Release is required. See Accessories page.
- Look at the garage door where it meets the floor. Any gap between the floor and the bottom of the door must not exceed 1/4". Otherwise, the safety reversal system may not work properly. See Adjustment Step 3. Floor or door should be repaired.

SECTIONAL DOOR INSTALLATIONS

- Do you have a steel, aluminum, fiberglass or glass panel door? If so, horizontal and vertical reinforcement is required (Installation Step 11).
- The opener should be installed above the center of the door. If there is a torsion spring or center bearing plate in the way of the header bracket, it may be installed within 4 feet to the left or right of the door center. See Installation Steps 1 and 11.
- If your door is more than 7 feet high, see rail extension kits listed on Accessories page.

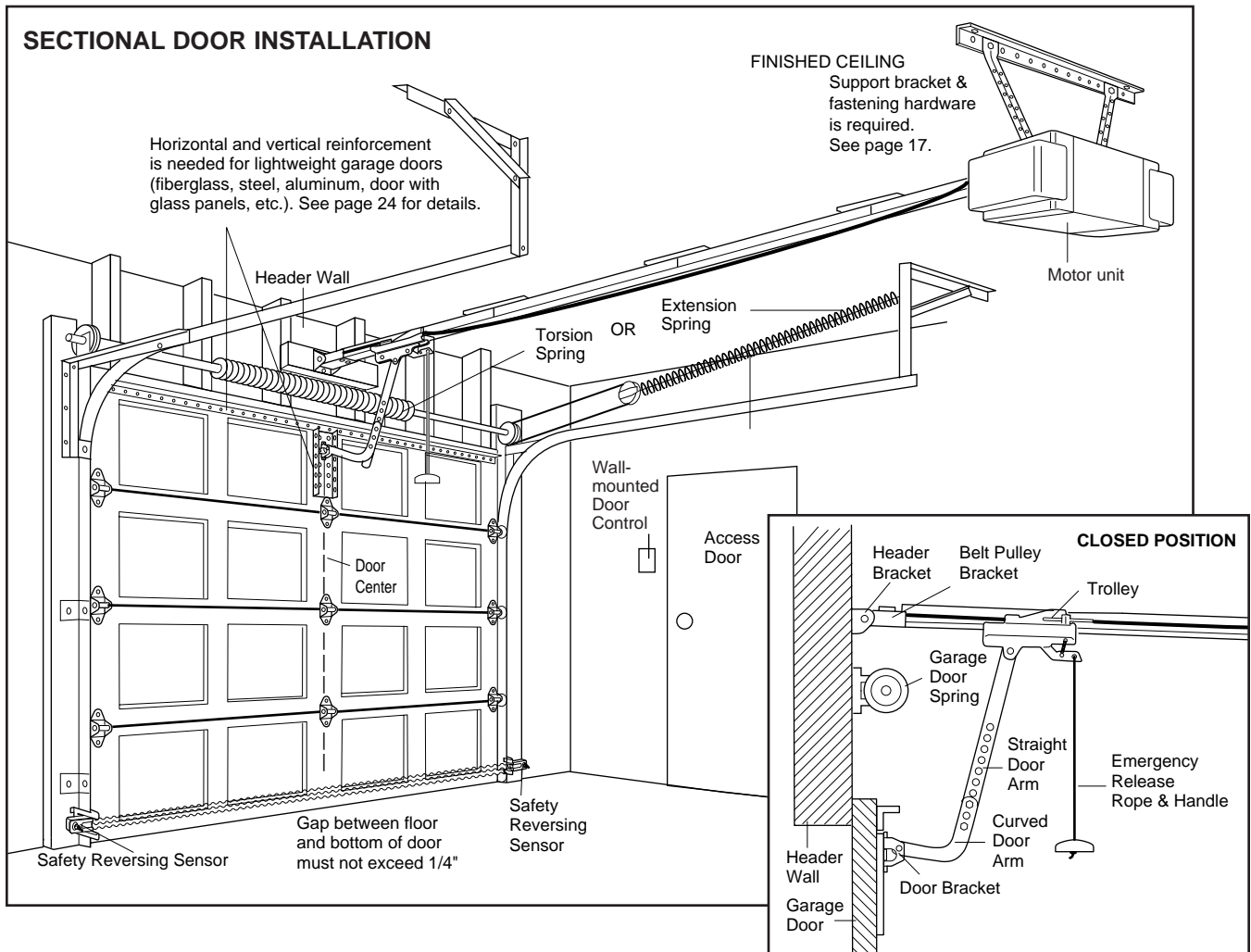

Planning (Continued)

ONE-PIECE DOOR INSTALLATIONS

- Generally, a one-piece door does not require reinforcement. If your door is lightweight, refer to the information relating to sectional doors in Installation Step 11.
- Depending on your door's construction, you may need additional mounting hardware for the door bracket (Step 11).

⚠ WARNING

Without a properly working safety reversal system, persons (particularly small children) could be SERIOUSLY INJURED or KILLED by a closing garage door.

- The gap between the bottom of the garage door and the floor **MUST NOT** exceed 1/4". Otherwise, the safety reversal system may not work properly.
- The floor or the garage door **MUST** be repaired to eliminate the gap.

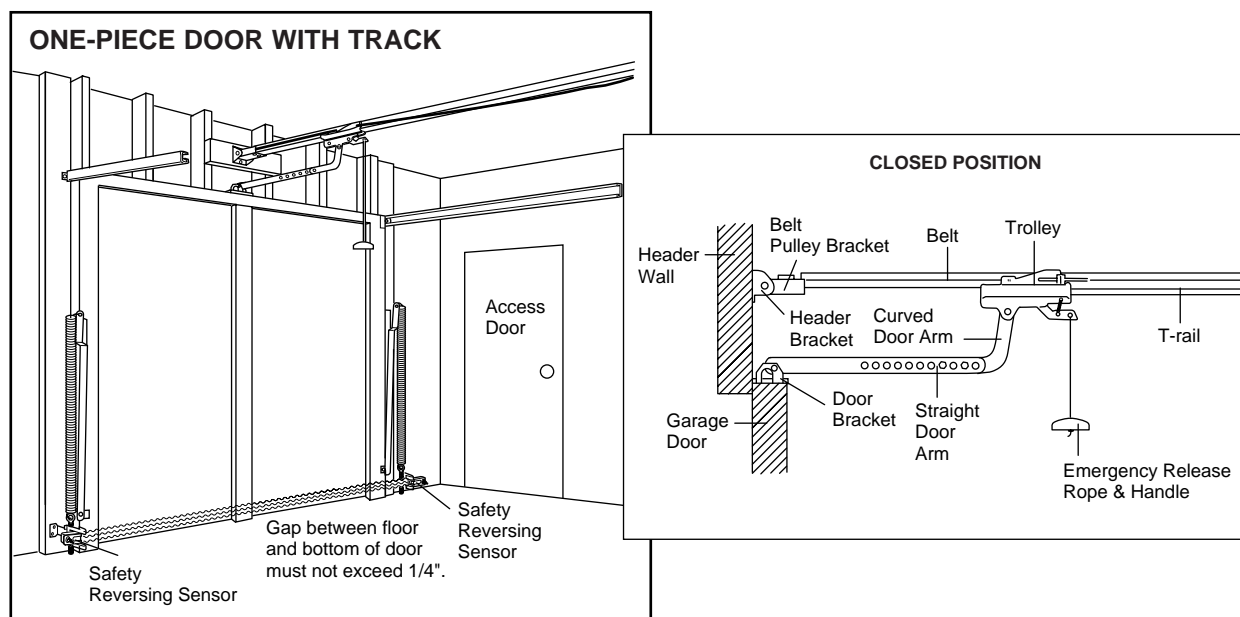
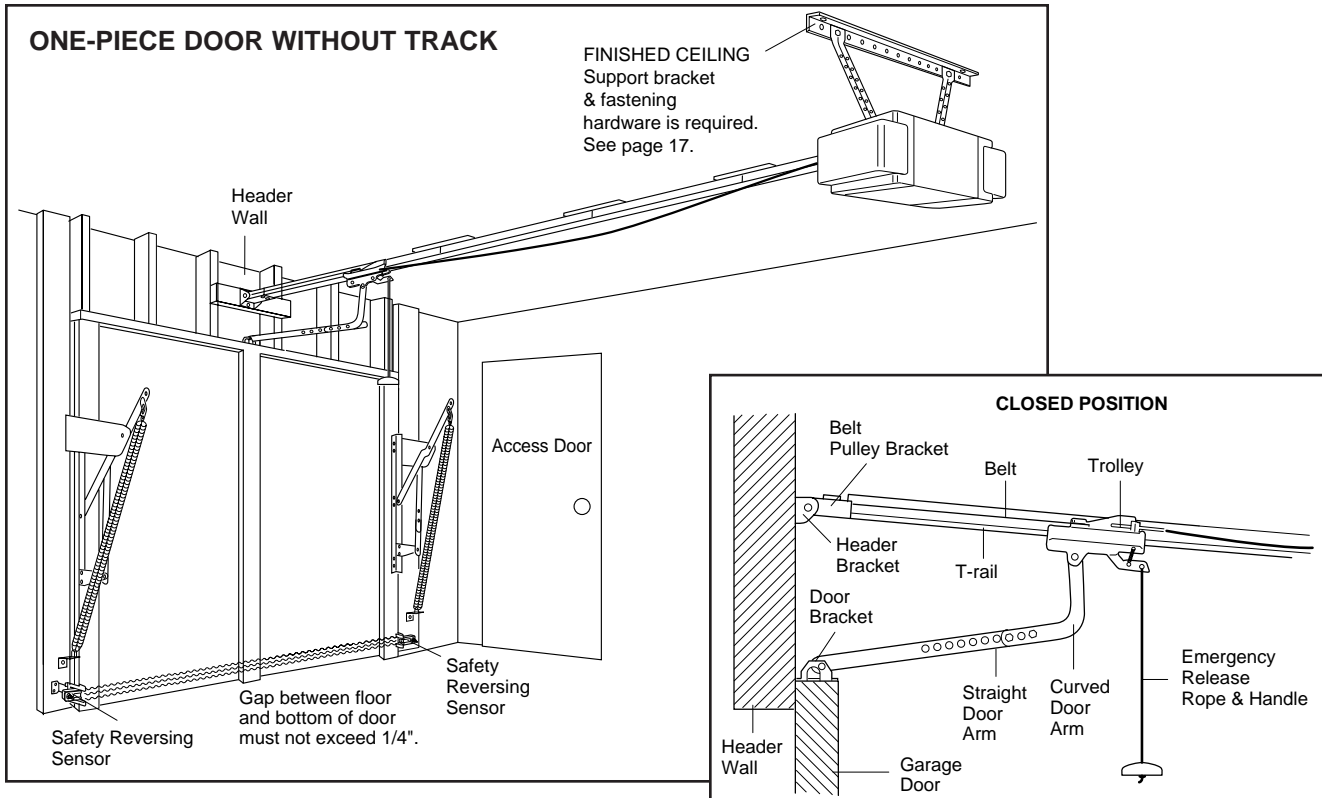

Carton Inventory

Your garage door opener is packaged in one carton which contains the motor unit and the parts illustrated below. Note that accessories will depend on the model purchased. If anything is missing, carefully check the packing material. Parts may be stuck in the



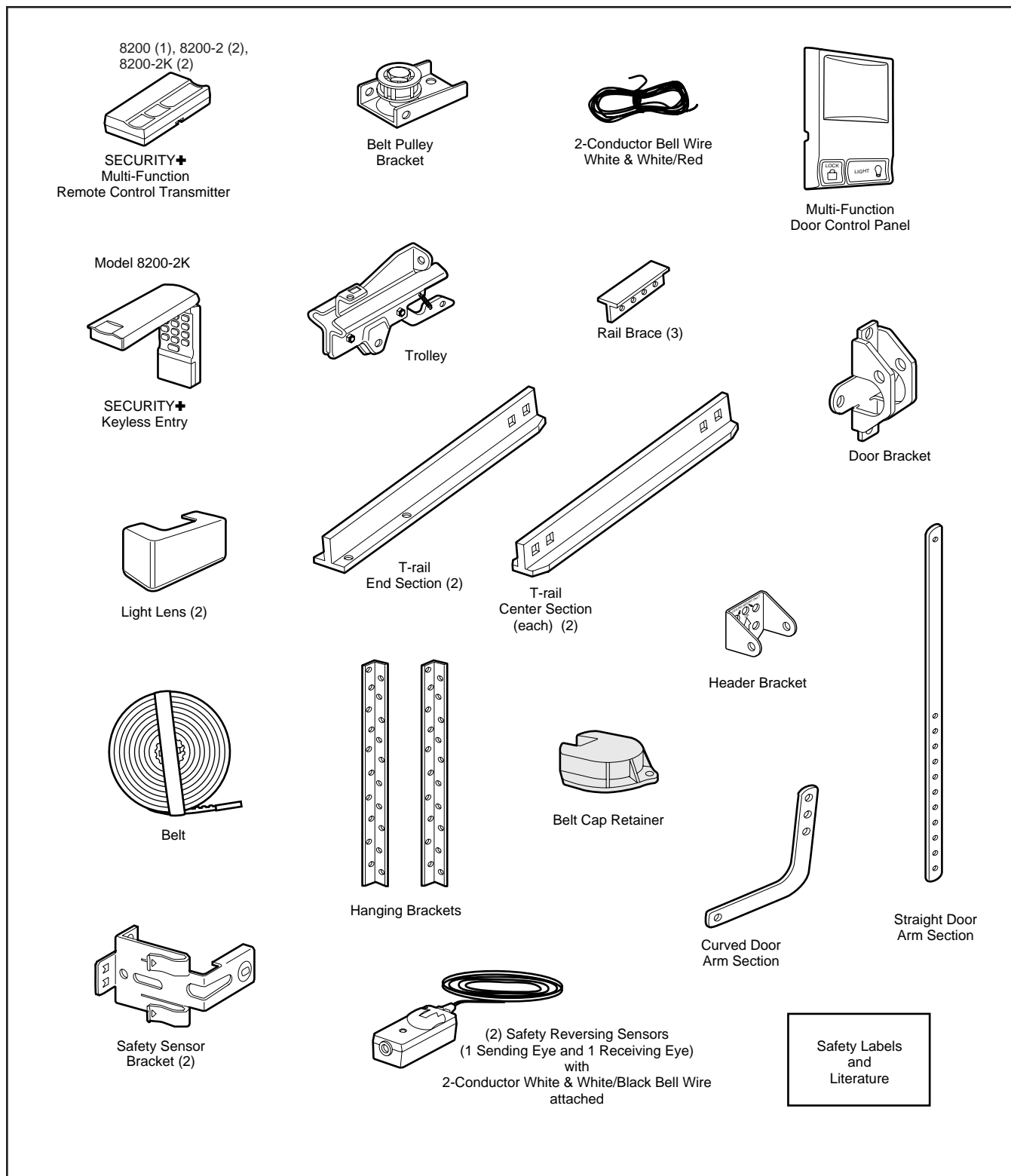

foam. Hardware for assembly and installation is shown on the next page. Save the carton and packing material until installation and adjustment is complete.





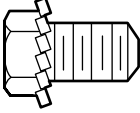
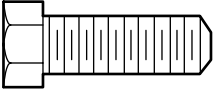

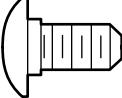
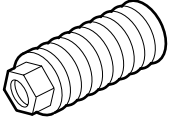
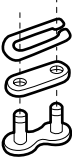
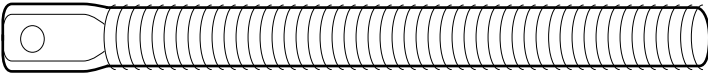

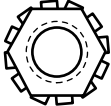
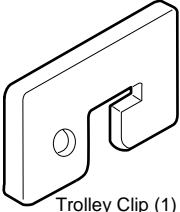



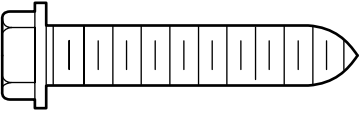
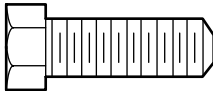

Hardware Inventory

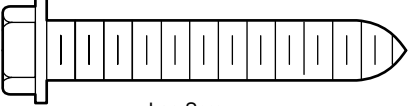
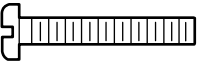
Separate all hardware and group as shown below for the assembly and installation procedures.

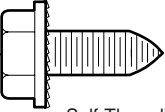
ASSEMBLY HARDWARE

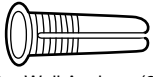
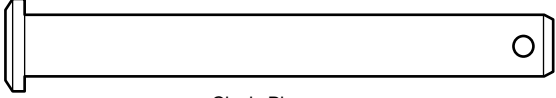
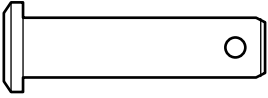
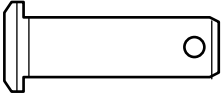
 Washed Screw 5/16"-18x1/2" (2) (mounted in motor unit)	 Hex Screw 5/16"-18x7/8" (4)	 Nut 5/16"-18 (4)	 Carriage Bolt 1/4"-20x1/2" (12)	 Spring/Trolley Nut (1)	 Master Link (2)
 Trolley Threaded Shaft (1)			 Lock Washer 5/16" (4)	 Lock Nut 1/4"-20x7/16" (12)	 Trolley Clip (1)

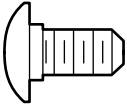
INSTALLATION HARDWARE

 Lag Screw 5/16"-9x1-5/8" (2)	 Hex Screw 5/16"-18x7/8" (4)	 Handle	 Rail Grease NO. 83A11-2	 Rope
 Lag Screw 5/16"-18x1-7/8" (2)	 Screw 6-32x1" (2)	 Ring Fastener (3)	 Lock Washer 5/16" (4)	
 Self-Threading Screw 1/4"-14x5/8"	 Screw 6ABx1-1/4" (2)	 Nut 5/16"-18 (4)	 Dry Wall Anchors (2)	
 Clevis Pin 5/16"x2-3/4" (1)	 Clevis Pin 5/16"x1-1/4" (1)	 Clevis Pin 5/16"x1" (1)		
 Insulated Staples (30)	 Carriage Bolt 1/4"-20x1/2" (2)	 Wing Nut 1/4"-20 (2)		

ASSEMBLY STEP 1

Assemble the T-Rail and Attach the Belt Pulley Bracket

To avoid installation difficulties, do not run the garage door opener until instructed to do so.

1. Align the four T-rail sections on a flat surface exactly as shown. Center sections are interchangeable. Front and back sections are also interchangeable for ease of assembly.

2. Insert the carriage bolts so the square bolt necks seat in the square holes in the T-rail sections and pass through the round holes in the rail braces.

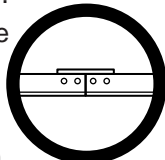

Make sure bolt necks are seated in the square holes and rails are aligned before you tighten lock nuts. Improper assembly can cause jerky trolley operation, noise and/or nuisance door reversals.

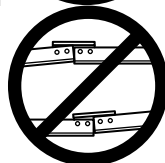

3. Assemble lock nuts, ensure alignment and tighten.

NOTE: If T-rail is not assembled exactly as shown, trolley will not travel smoothly along length of rail or it will hit against nuts.

4. Position the belt pulley bracket on the front end of the T-rail as shown. Fasten securely with the hardware shown.

NOTE: When tightening the screws, be sure to keep bracket parallel to the rail. Otherwise, the rail may bow when the opener is operated.

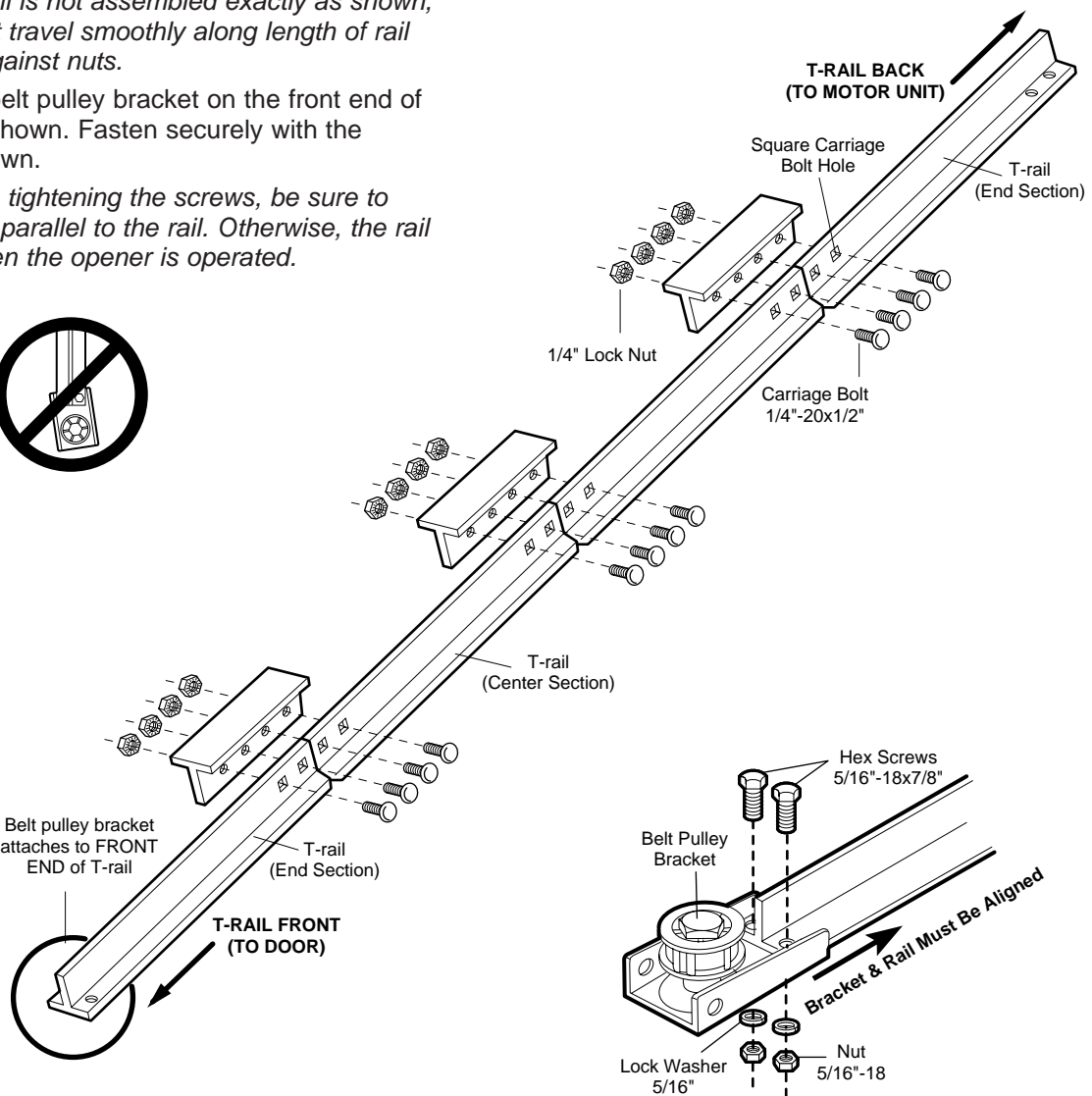
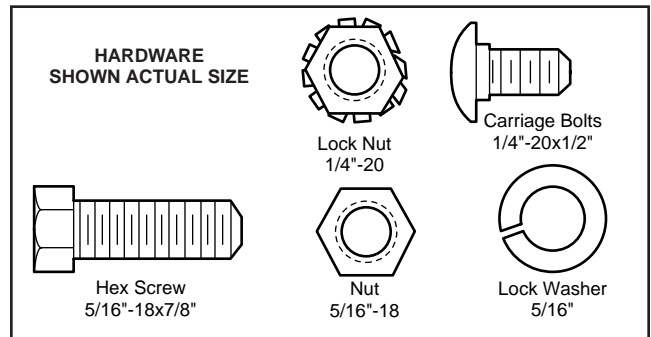
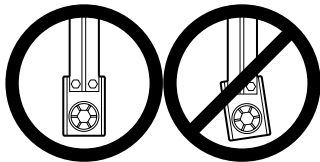

ASSEMBLY STEP 2

Install the Trolley

- As a temporary stop, insert a screwdriver into the hole in the front end of the T-rail.
- Slide the trolley assembly along the rail to the screwdriver stop. **NOTE:** If trolley hits against any nuts on the T-rail, the bolts and nuts were attached from the wrong side and must be repositioned. Review Assembly Step 1.
- Insert a 5/16"-18x7/8" hex screw into the trolley stop hole in the T-rail as shown. Tighten securely with a 5/16" lock washer and nut. This screw limits trolley travel in the DOWN direction.

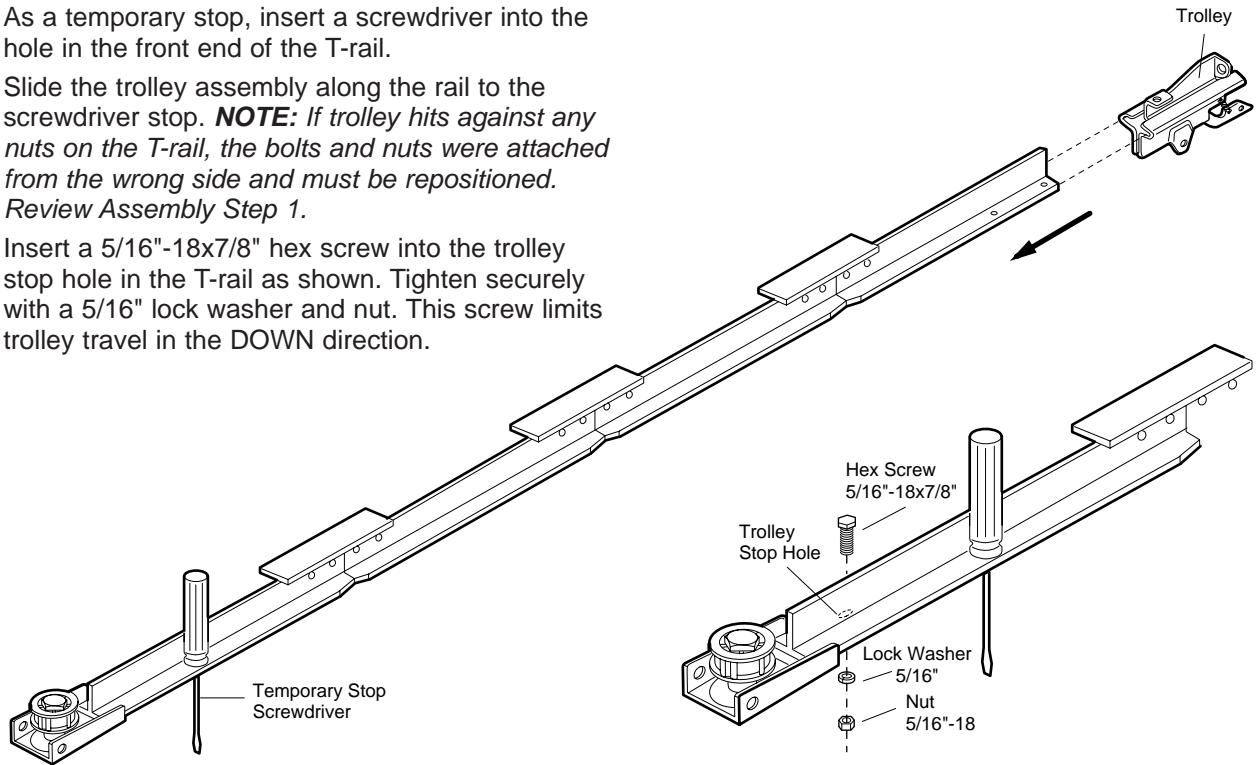

ASSEMBLY STEP 3

Fasten the T-Rail to the Motor Unit

- Place the opener on packing material to protect the cover. For convenience, put a support under the belt pulley bracket.
- Remove the two 5/16"-18x1/2" washered screws mounted in the top of the motor unit.
- Align the holes in the back section of the T-rail with the holes in the motor unit.
- Fasten the rail with the two washered screws previously removed. Tighten securely. **Remember to use only these screws! Any other screws will cause serious damage to the opener.**
- Insert a 5/16"-18x7/8" hex screw into the cover protection bolt hole in the T-rail as shown. Tighten securely with a 5/16" lock washer and nut.

NOTE: This screw prevents trolley over-travel. Keep a 2" minimum between the trolley and this screw when adjusting travel limits (see page 28).

CAUTION

To avoid serious damage to opener, ONLY use screws mounted in top of motor unit.

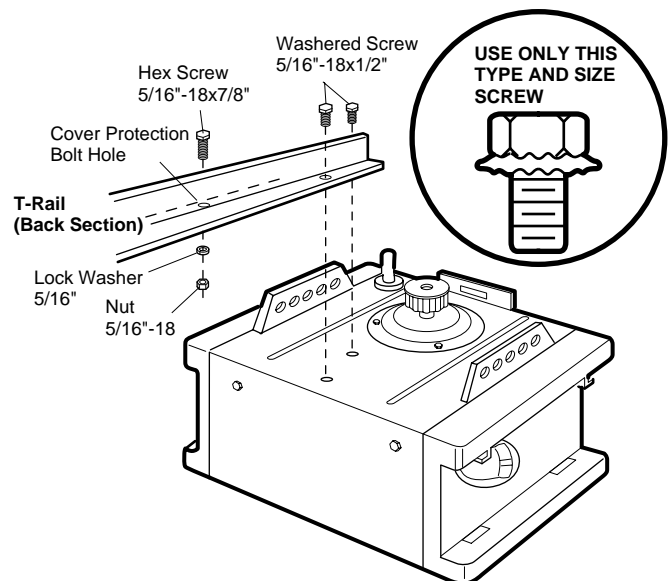

HARDWARE SHOWN ACTUAL SIZE

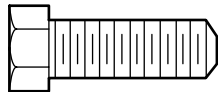

Hex Screw
5/16"-18x7/8"



Nut
5/16"-18

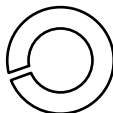

Lock Washer
5/16"

ASSEMBLY STEP 4

Install the Belt and Set the Tension

INSTALLING THE BELT

1. Drop the notched side of the trolley clip into the retaining slot on top of the trolley (see Figure 1).
2. Grasp the clip connector at the end of the belt and slip it through the belt pulley bracket from behind, around the pulley and toward the trolley.
3. Fasten the belt clip connector to the trolley clip with a master link:
 - Push pins of master link bar through holes in trolley clip and belt clip connector.
 - Push master link cap over pins and past pin notches.
 - Slide clip-on spring over cap and onto pin notches until both pins are securely locked in place.
4. With the trolley against the screwdriver, dispense the belt along the rail and around the motor unit sprocket. The sprocket teeth must engage the belt (Figure 2).
5. Use the second master link to connect the belt to the flat end of the trolley threaded shaft (Figure 1). **Check to make sure the belt is not twisted.**
6. Remove the screwdriver.

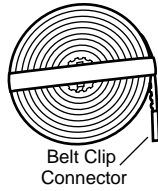

Slip Belt Clip Connector around Pulley Bracket from this direction and attach to trolley clip

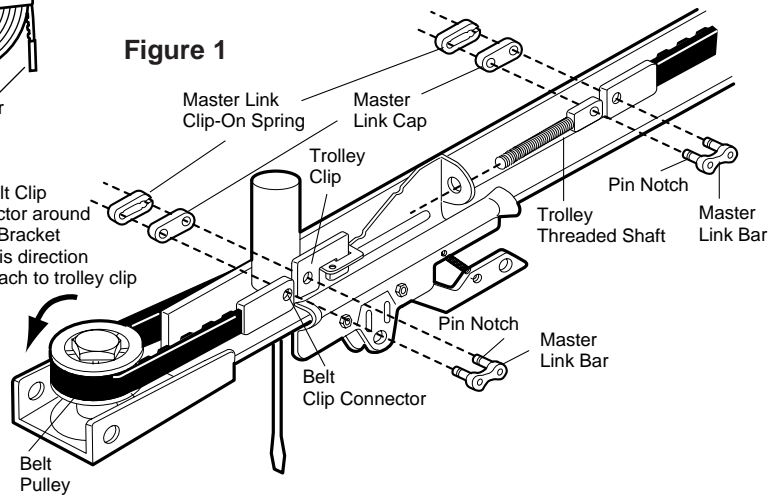
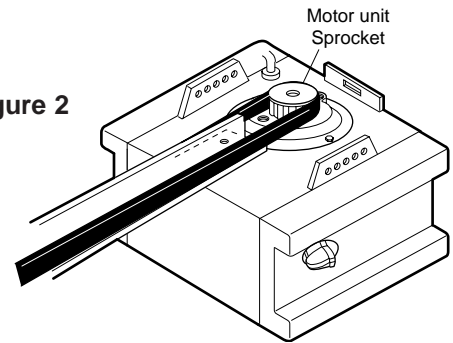

Figure 1

Figure 2



SETTING THE TENSION

1. Insert the trolley threaded shaft through the hole in the trolley.
2. Hold the belt at the trolley shaft to avoid twisting as you thread the spring/trolley nut by hand on the shaft until finger tight against the trolley (Figure 3). Do not use any tools.
3. Insert a screwdriver tip into one of the nut ring slots and brace it firmly against the trolley. (Figure 4).
4. Place a 7/16" open end wrench on the square end. Rotate about 1/4 turn until the spring releases and snaps the nut ring against the trolley (Figure 5). This extends the spring for optimum belt tension.

Figure 3

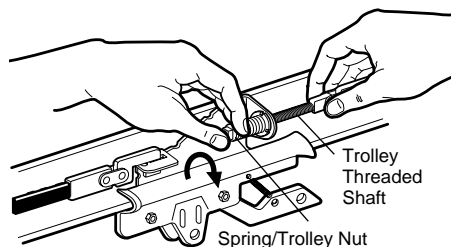

Figure 4

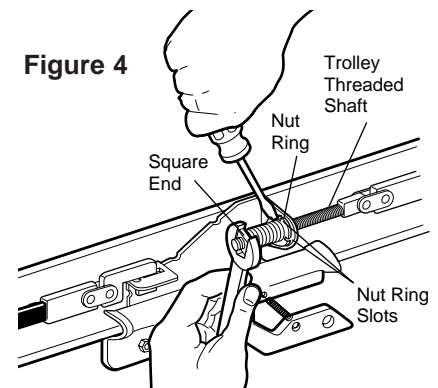
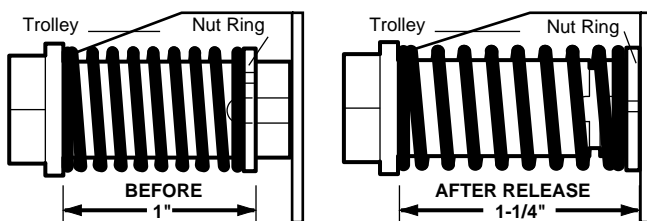

Figure 5



⚠ WARNING

To avoid possible SERIOUS INJURY to fingers from moving garage door opener:

- ALWAYS keep hand clear of sprocket while operating opener.
- Securely attach sprocket cover before operating.

ASSEMBLY STEP 5

Attach the Belt Cap Retainer

- Position the belt cap retainer over the motor unit sprocket so the two holes in cap align with the two holes in mounting plate. Attach with 8x3/8" hex screws provided.

You have now finished assembling your garage door opener. Please read the following warnings before proceeding to the installation section.

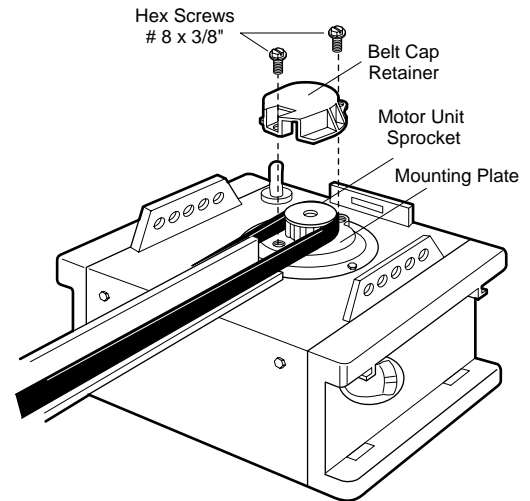

HARDWARE SHOWN
ACTUAL SIZE



Hex Screw
#8x3/8"

INSTALLATION

IMPORTANT INSTALLATION INSTRUCTIONS

⚠ WARNING

To reduce the risk of severe injury or death:

1. READ AND FOLLOW ALL INSTALLATION WARNINGS AND INSTRUCTIONS.
2. Install garage door opener only on properly balanced and lubricated garage door. An improperly balanced door may not reverse when required and could result in severe injury or death.
3. All repairs to cables, spring assemblies and other hardware MUST be made by a trained door systems technician before installing opener.
4. Disable all locks and remove all ropes connected to garage door before installing opener to avoid entanglement.
5. Install garage door opener 7 feet or more above floor.
6. Mount emergency release handle 6 feet above floor.
7. NEVER connect garage door opener to power source until instructed to do so.
8. NEVER wear watches, rings or loose clothing while installing or servicing opener. They could be caught in garage door or opener mechanisms.
9. Install wall-mounted garage door control:
 - within sight of the garage door
 - out of reach of children at minimum height of 5 feet
 - away from all moving parts of the door.
10. Place entrapment warning label on wall next to garage door control.
11. Place manual release/safety reverse test label in plain view on inside of garage door.
12. Upon completion of installation, test safety reversal system. Door MUST reverse on contact with a one-inch high object (or a 2x4 laid flat) on the floor.

INSTALLATION STEP 1

Determine the Header Bracket Location

⚠ WARNING

To prevent possible **SERIOUS INJURY** or **DEATH**:

- Header bracket **MUST** be **RIGIDLY** fastened to structural support on header wall or ceiling, otherwise garage door might not reverse when required. **DO NOT** install header bracket over drywall.
- Concrete anchors **MUST** be used if mounting header bracket or 2x4 into masonry.
- **NEVER** try to loosen, move or adjust garage door, springs, cables, pulleys, brackets, or their hardware, all of which are under **EXTREME** tension.
- **ALWAYS** call a trained door systems technician if garage door binds, sticks, or is out of balance. An unbalanced garage door might not reverse when required.

Installation procedures vary according to garage door types. Follow the instructions which apply to your door.

SECTIONAL DOOR AND ONE-PIECE DOOR WITH TRACK

1. Close the door and mark the inside vertical centerline of the garage door.
2. Extend the line onto the header wall above the door.

You can fasten the header bracket within 4 feet of the left or right of the door center only if a torsion spring or center bearing plate is in the way; or you can attach it to the ceiling (see page 14) when clearance is minimal. (It may be mounted on the wall upside down if necessary, to gain approximately 1/2".)

If you need to install the header bracket on a 2x4 (on wall or ceiling), use lag screws (not provided) to securely fasten the 2x4 to structural supports as shown here and on page 13.

3. Open your door to the highest point of travel as shown. Draw an intersecting horizontal line on the header wall 2" above the high point. This height will provide travel clearance for the top edge of the door.

Proceed to Step 2, page 14.

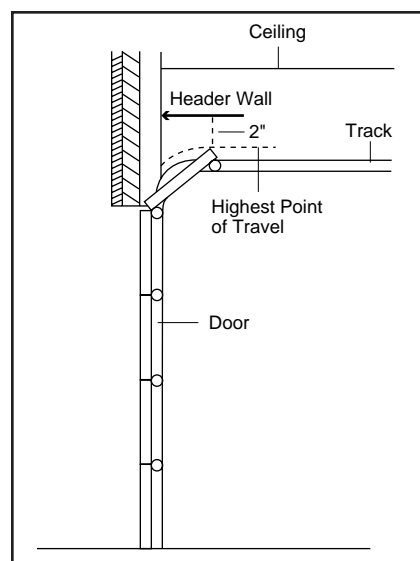
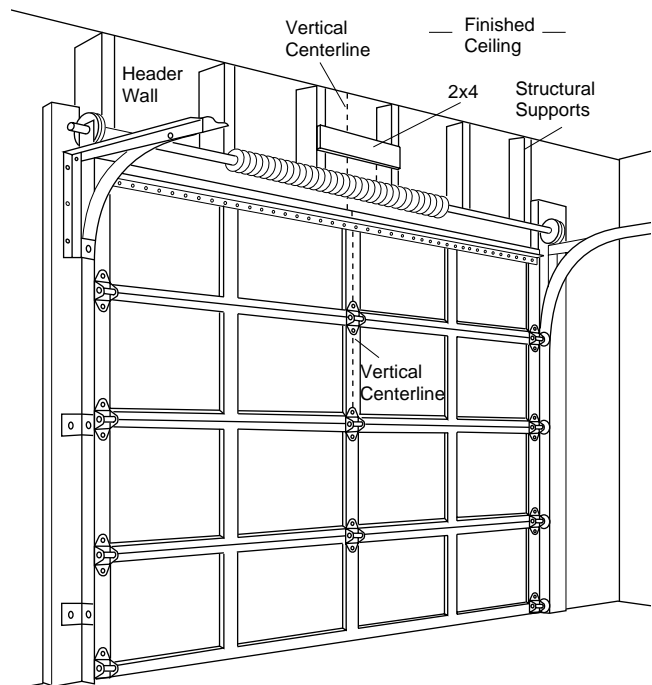

**Sectional door
with curved
track**

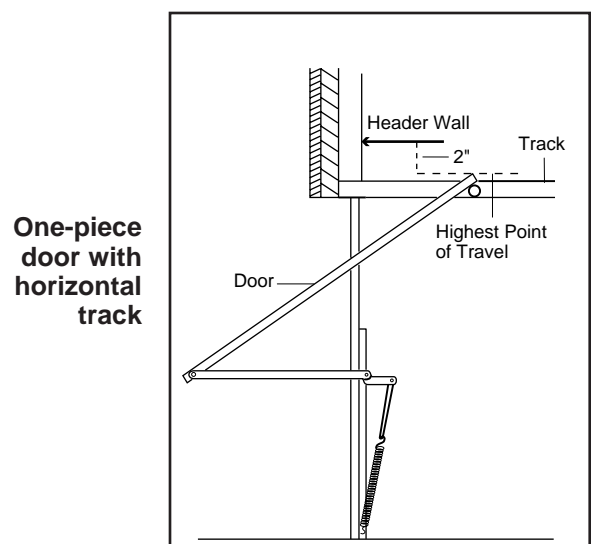

**One-piece
door with
horizontal
track**

ONE-PIECE DOOR WITHOUT TRACK

1. Close the door and mark the inside vertical centerline of your garage door. Extend the line onto the header wall above door, as shown.

If headroom clearance is minimal, you can install the header bracket on the ceiling. See page 14.

If you need to install the header bracket on a 2x4 (on wall or ceiling), use lag screws (not provided) to securely fasten the 2x4 to structural supports as shown.

2. Open your door to the highest point of travel as shown. Measure the distance from the top of the door to the floor. Subtract the actual height of the door. Add 8" to the remainder. (See Example).
3. Close the door and draw an intersecting horizontal line on the header wall at the determined height.

NOTE: If the total number of inches exceeds the height available in your garage, use the maximum height possible, or refer to page 14 for ceiling installation.

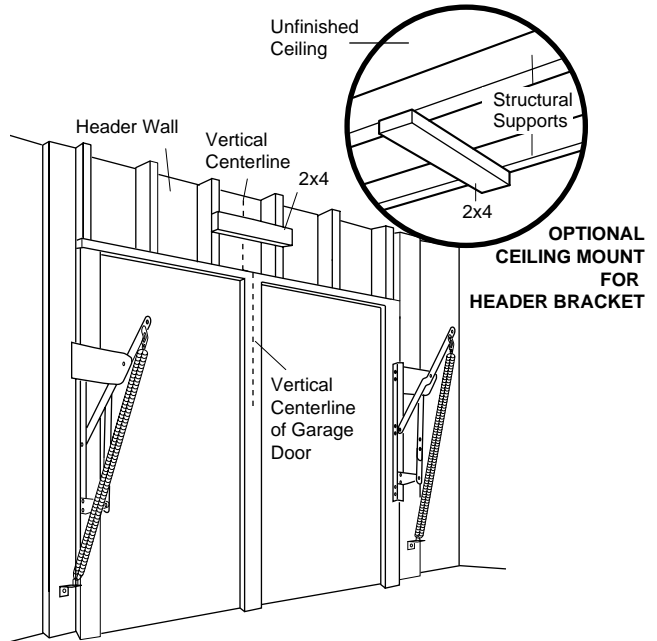

EXAMPLE

Distance from top of door (at highest point of travel) to floor	92"
Actual height of door	-88"
Remainder.....	4"
Add	+8"
Bracket height on header wall.....	=12"

(Measure UP from top of CLOSED door.)

Proceed to Step 2, page 14.

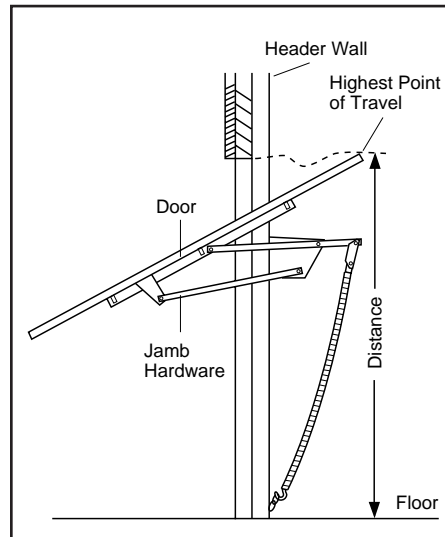

**One-piece door without track:
jamb hardware**

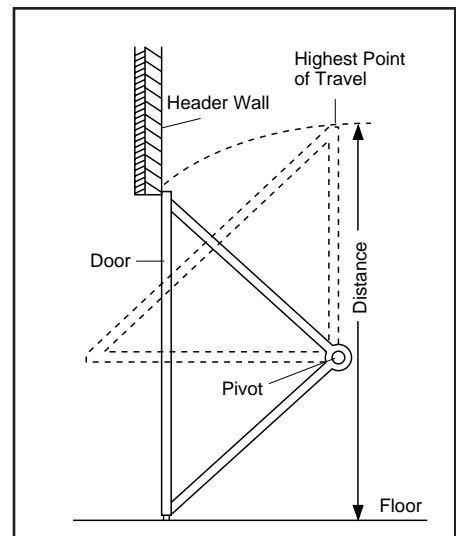

**One-piece door without track:
pivot hardware**

INSTALLATION STEP 2

Install the Header Bracket

You can attach the header bracket either to the wall above the garage door, or to the ceiling. Follow the instructions which will work best for your particular requirements. **Do not install the header bracket over drywall. If installing into masonry, use concrete anchors (not provided).**

WALL HEADER BRACKET INSTALLATION

- Center the bracket on the vertical centerline with the bottom edge of the bracket on the horizontal line as shown (with the arrow pointing toward the ceiling).
- Mark the vertical set of bracket holes (do not use the holes designated for ceiling mount). Drill 3/16" pilot holes and fasten the bracket securely to a structural support with the hardware provided.

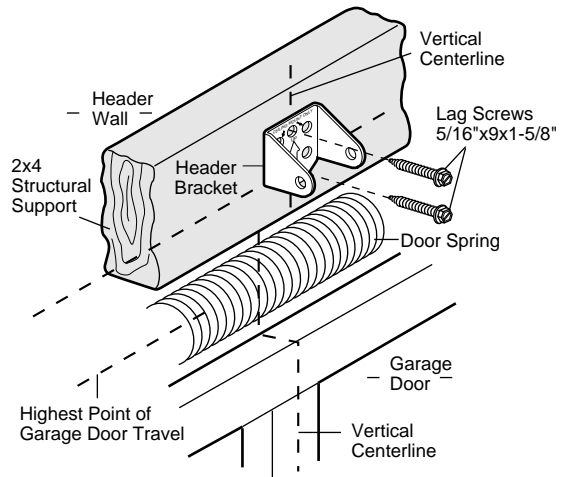
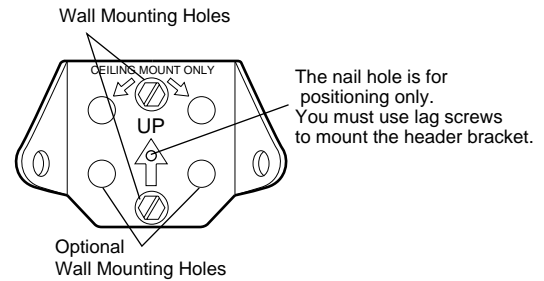
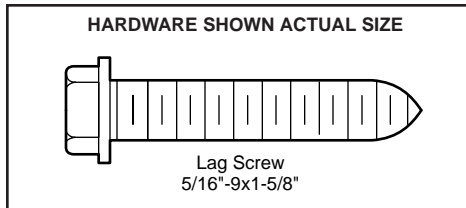

CEILING HEADER BRACKET INSTALLATION

- Extend the vertical centerline onto the ceiling as shown.
- Center the bracket on the vertical mark, no more than 6" from the wall. Make sure the arrow is pointing toward the wall. The bracket can be mounted flush against the ceiling when clearance is minimal.
- Mark the side holes. Drill 3/16" pilot holes and fasten bracket securely to a structural support with the hardware provided.

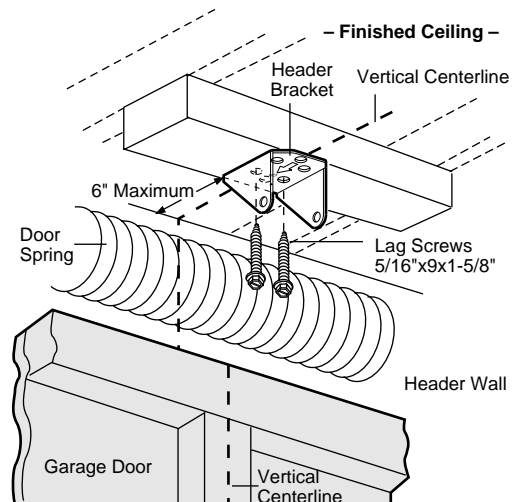
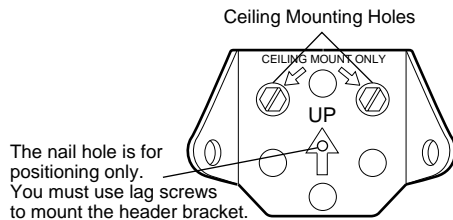

INSTALLATION STEP 3

Attach the T-Rail to the Header Bracket

- Position the opener on the garage floor below the header bracket. Use packing material as a protective base.

NOTE: If the door spring is in the way you'll need help. Have someone hold the opener securely on a temporary support to allow the rail to clear the spring.

- Position the rail bracket against the header bracket.
- Align the bracket holes and join with a clevis pin as shown.
- Insert a ring fastener to secure.

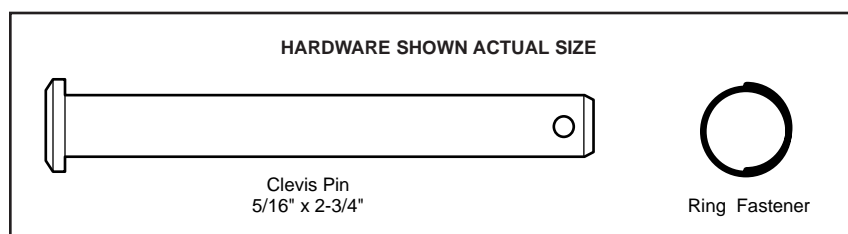
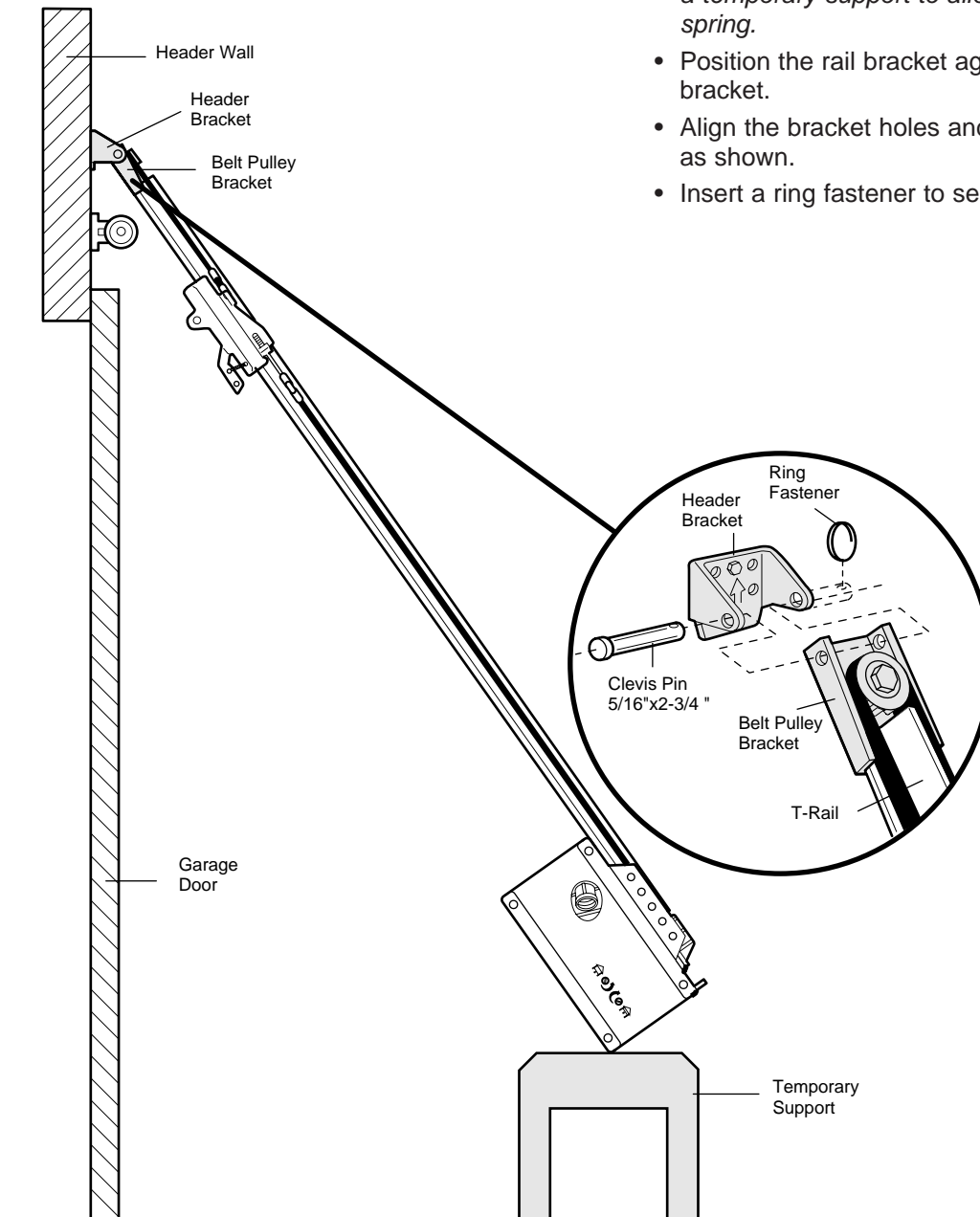

INSTALLATION STEP 4

Position the Opener

Follow instructions which apply to your door type as illustrated.

SECTIONAL DOOR OR ONE-PIECE DOOR WITH TRACK

A 2x4 laid flat is convenient for setting an ideal door-to-T-rail distance.

- Raise the opener onto a stepladder. You will need help at this point if the ladder is not tall enough.
- Open the door all the way and place a 2x4 laid flat on the top section beneath the T-rail.
- If the top section or panel hits the trolley when you raise the door, pull down on the trolley release arm to disconnect inner and outer sections. Slide the outer trolley toward the motor unit. The trolley can remain disconnected until Installation Step 12 is completed.

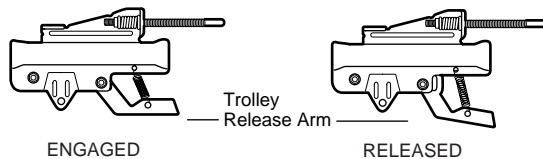

CAUTION

To prevent damage to garage door, rest garage door opener rail on 2x4 placed on top section of door.

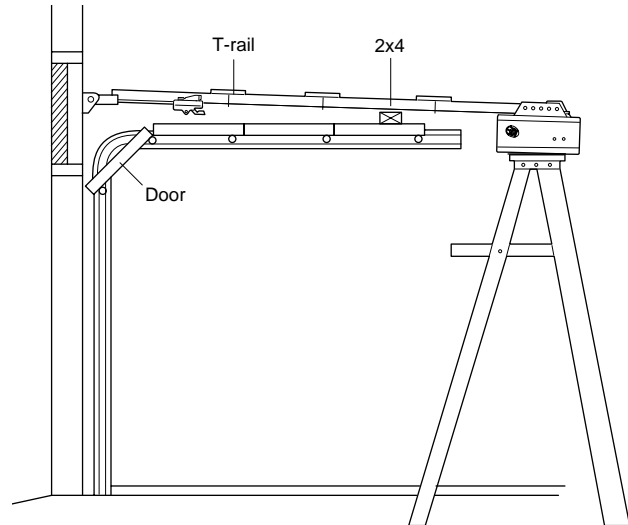

ONE-PIECE DOOR WITHOUT TRACK

- With the door fully open and parallel to the floor, measure the distance from the floor to the top of the door.
- Using a stepladder as a support, raise the top of the opener to this height.
- The top of the door should be level with the top of the motor unit. Do not position the opener more than 2" above this point.

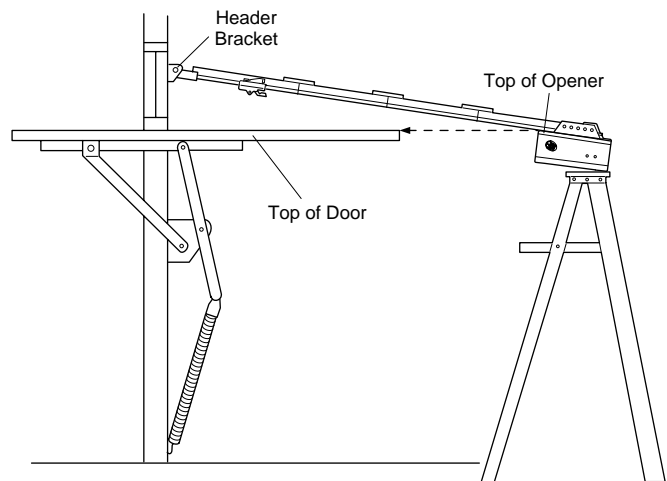

INSTALLATION STEP 5

Hang the Opener

Two representative installations are shown. Yours may be different. Hanging brackets should be angled (Figure 1) to provide rigid support. On finished ceilings (Figure 2), attach a sturdy metal bracket to structural supports before installing the opener. This bracket and fastening hardware are not provided.

1. Measure the distance from each side of the motor unit to the structural support.
2. Cut both pieces of the hanging bracket to required lengths.
3. Drill 3/16" pilot holes in the structural supports.
4. Attach one end of each bracket to a support with 5/16"-18x1-7/8" lag screws.
5. Fasten the opener to the hanging brackets with 5/16"-18x7/8" hex screws, lock washers and nuts.
6. Check to make sure the T-rail is centered over the door (or in line with the header bracket if the bracket is not centered above the door).
7. Remove the 2x4. Operate the door manually. If the door hits the rail, raise the header bracket.
8. Grease the top and underside of the rail surface where the trolley slides with rail grease.

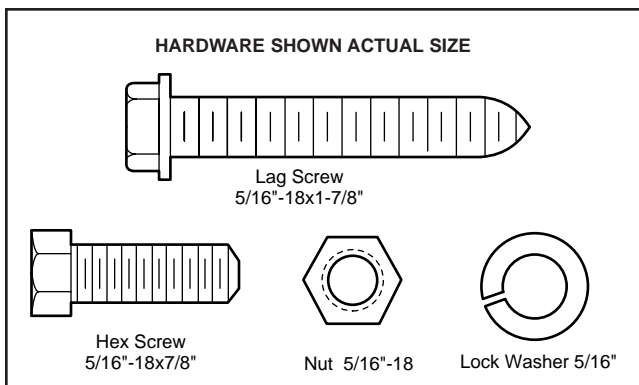
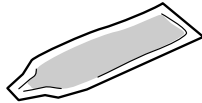

⚠ WARNING

To avoid possible **SERIOUS INJURY** from a falling garage door opener, fasten it **SECURELY** to structural supports of the garage. Concrete anchors **MUST** be used if installing any brackets into masonry.

Figure 1

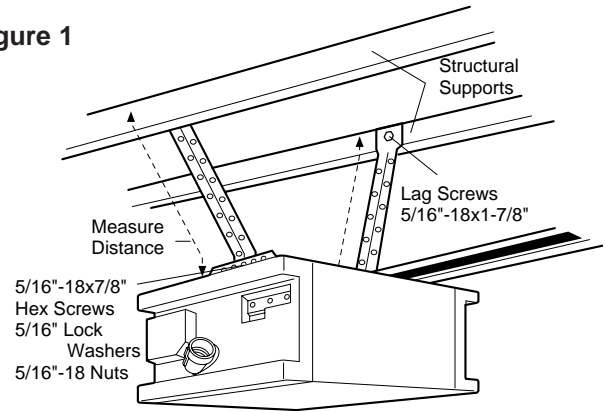
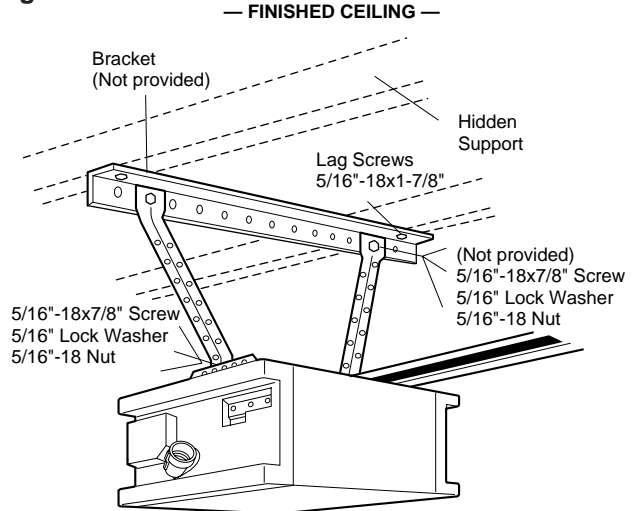

Figure 2



INSTALLATION STEP 6

Install the Door Control

Locate door control within sight of the door at a minimum height of 5 feet where small children cannot reach, and away from moving parts of the door and door hardware. If installing into drywall (Fig. 1), drill 5/32" holes and use anchors provided. For pre-wired installations (as in new home construction), it may be mounted to a single gang box (Fig. 2).

NOTE: After installation, a green indicator light behind the cover will indicate proper connection. If not lit, the Lock and Light features will not function (reverse wires to correct).

1. Strip 1/4" of insulation from one end of bell wire and connect to the two screw terminals on back of door control by color: white wire to 2 and white/red wire to 1 (Fig. 3).
2. Remove white cover by gently pushing both thumbs against upper corners of cover on back side of door control (Fig. 4). Fasten with 6ABx1-1/4" self-tapping screws (standard installation) or 6-32x1" machine screws (into gang box) as follows:

- Drill and install bottom screw, allowing 1/8" to protrude above wall surface.
 - Position bottom of door control on screw head and slide down to secure. Adjust screw for snug fit.
 - Install top screw with care to avoid cracking plastic housing. **Do not overtighten.**
 - Insert bottom tabs and snap on cover. (To remove cover after mounting, gently pry at top with paper clip or small flat head screwdriver.)
3. (**Standard installation only**) Run bell wire up wall and across ceiling to motor unit. Use insulated staples to secure wire in several places. Do not pierce wire with a staple, creating a short or open circuit.
 4. Connect bell wire to the opener terminal screws as follows: white to 2 and white/red to 1. (Fig. 5).
 5. Use tacks or staples to permanently attach entrapment warning label to wall near door control, and manual release/safety reverse test label in a prominent location on inside of garage door.

NOTE: DO NOT connect the power and operate the opener at this time. The trolley will travel to the full open position but will not return to the close position until the sensor beam is connected and properly aligned. See Safety Reversing Sensor Instructions beginning on page 21.

WARNING

To prevent possible serious injury or death from electrocution:

- Be sure power is not connected before installing door control.
- Connect only to 24 VOLT low voltage wires.

To prevent possible serious injury or death from a closing garage door:

- Install door control within sight of garage door, out of reach of children at a minimum height of 5 feet, and away from all moving parts of door.
- Never permit children to operate or play with door control push buttons or remote control transmitters.
- Activate door only when it can be seen clearly, is properly adjusted, and there are no obstructions to door travel.
- Always keep garage door in sight until completely closed. Never permit anyone to cross path of closing garage door.

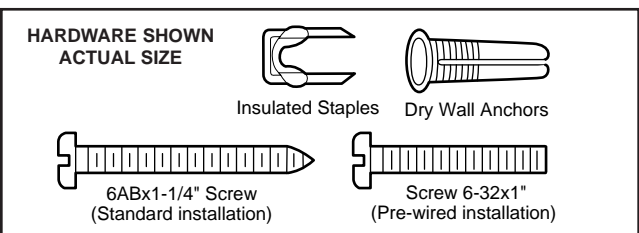

Figure 1 STANDARD INSTALLATION

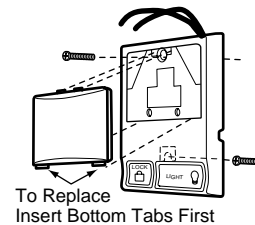

Figure 2 PRE-WIRED INSTALLATION

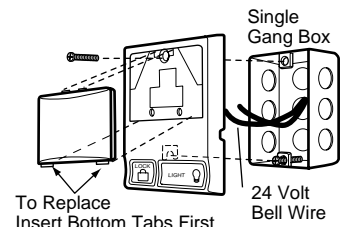

Figure 3 MULTI-FUNCTION DOOR CONTROL (BACK)

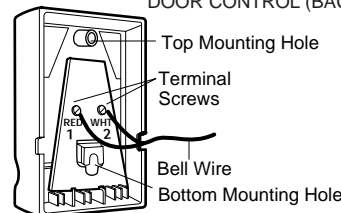

Figure 4 REMOVE COVER

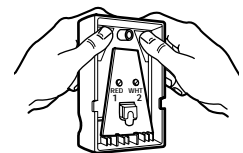
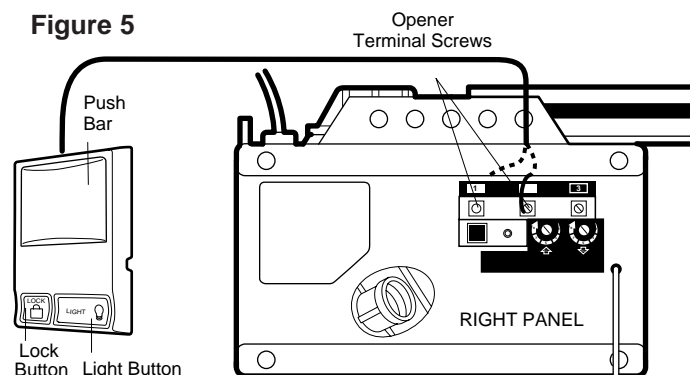

Figure 5



INSTALLATION STEP 7

Install the Lights and Lenses

INSTALL THE LIGHTS

- Install a 75 watt maximum light bulb in each socket. The lights will turn ON and remain lit for approximately 4-1/2 minutes when power is connected. Then the lights will turn OFF.
- If the bulbs burn out prematurely due to vibration, replace with a Garage Door Opener bulb.

INSTALL THE LENSES

- Slide lenses into guides. Snap bottom tabs into lens slots.
- Reverse the procedure to remove the lenses.

NOTE: For convenience, the lenses may be installed after Adjustment Step 3 on page 30.

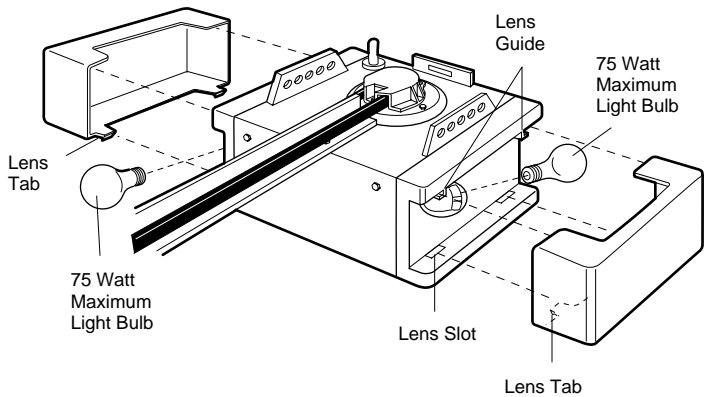

INSTALLATION STEP 8

Attach the Emergency Release Rope and Handle

- Thread one end of the rope through the hole in the top of the red handle so "NOTICE" reads right side up as shown. Secure with an overhand knot at least 1" from the end of the rope to prevent slipping.
- Thread the other end of the rope through the hole in the release arm of the outer trolley.
- Adjust rope length so the handle is 6 feet above the floor. Secure with an overhand knot.

NOTE: If it is necessary to cut the rope, heat seal the cut end with a match or lighter to prevent unraveling.

⚠ WARNING

- To prevent possible **SERIOUS INJURY** or **DEATH** from a falling garage door:
 - If possible, use emergency release handle to disengage trolley **ONLY** when garage door is **CLOSED**. Weak or broken springs or unbalanced door could result in an open door falling rapidly and/or unexpectedly.
 - **NEVER** use emergency release handle unless garage doorway is clear of persons and obstructions.
- **NEVER** use handle to pull door open or closed. If rope knot becomes untied, you could fall.

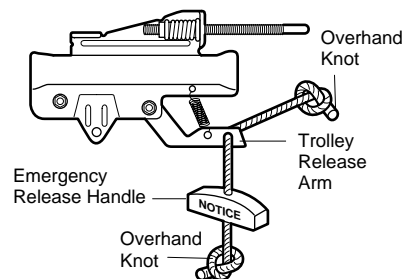

INSTALLATION STEP 9

Electrical Requirements

To avoid installation difficulties, do not run the opener at this time.

To reduce the risk of electric shock, your garage door opener has a grounding type plug with a third grounding pin. This plug will only fit into a grounding type outlet. If the plug doesn't fit into the outlet you have, contact a qualified electrician to install the proper outlet.

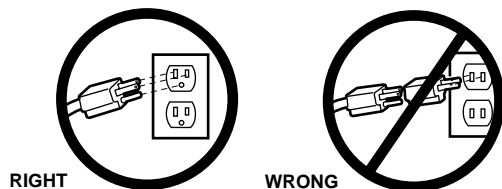

If permanent wiring is required by your local code, refer to the following procedure.

To make a permanent connection through the 7/8" hole in the top of the motor unit:

- Remove the motor unit cover screws and set the cover aside.
- Remove the attached 3-prong cord.
- Connect the black (line) wire to the screw on the brass terminal; the white (neutral) wire to the screw on the silver terminal; and the ground wire to the green ground screw. **The opener must be grounded.**
- Reinstall the cover.

To avoid installation difficulties, do not run the opener at this time.

WARNING

To prevent possible **SERIOUS INJURY** or **DEATH** from electrocution or fire:

- Be sure power is not connected to the opener, and disconnect power to circuit **BEFORE** removing cover to establish permanent wiring connection.
- Garage door installation and wiring **MUST** be in compliance with all local electrical and building codes.
- **NEVER** use an extension cord, 2-wire adapter, or change plug in any way to make it fit outlet. Be sure the opener is grounded.

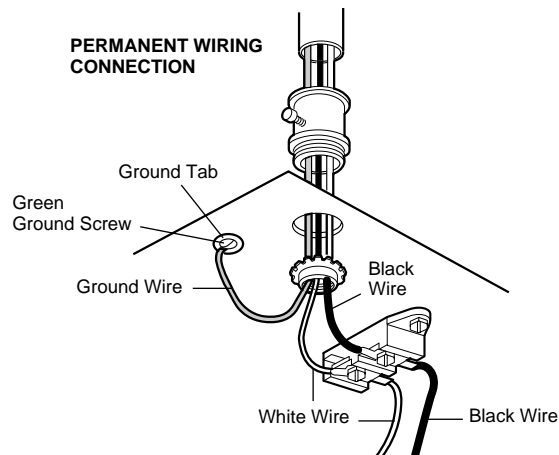

INSTALLATION STEP 10

Install The Protector System®

The safety reversing sensor must be connected and aligned correctly before the garage door opener will move in the down direction.

IMPORTANT INFORMATION ABOUT THE SAFETY REVERSING SENSOR

When properly connected and aligned, the sensor will detect an obstacle in the path of its electronic beam. The sending eye (with an orange indicator light) transmits an invisible light beam to the receiving eye (with a green indicator light). If an obstruction breaks the light beam while the door is closing, the door will stop and reverse to full open position, and the opener lights will flash 10 times.

The units must be installed inside the garage so that the sending and receiving eyes face each other across the door, no more than 6" above the floor. Either can be installed on the left or right of the door as long as the sun never shines directly into the receiving eye lens.

The mounting brackets are designed to clip onto the track of sectional garage doors without additional hardware.

! WARNING

- Be sure power is not connected to the garage door opener BEFORE installing the safety reversing sensor.
- To prevent SERIOUS INJURY or DEATH from a closing garage door:
 - Correctly connect and align the safety reversing sensor. This required safety device MUST NOT be disabled.
 - Install the safety reversing sensor so beam is NO HIGHER than 6" above garage floor.

If it is necessary to mount the units on the wall, the brackets must be securely fastened to a solid surface such as the wall framing. Extension brackets (see accessories) are available if needed. If installing in masonry construction, add a piece of wood at each location to avoid drilling extra holes in masonry if repositioning is necessary.

The invisible light beam path must be unobstructed. No part of the garage door (or door tracks, springs, hinges, rollers or other hardware) may interrupt the beam while the door is closing.

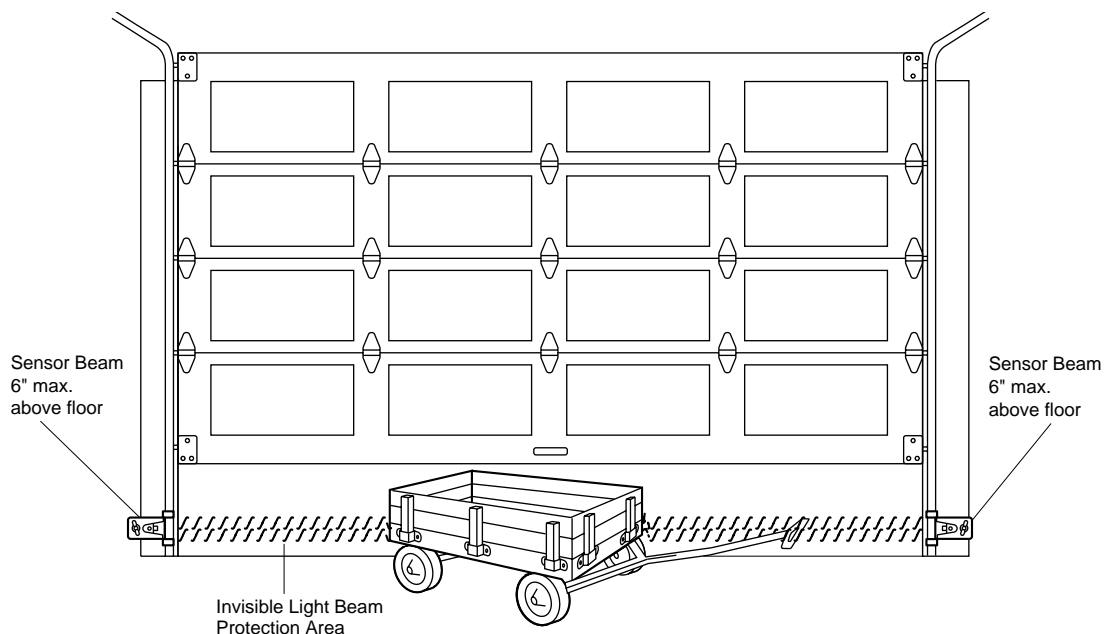

Facing the door from inside the garage

INSTALLING THE BRACKETS

Be sure power to the opener is disconnected.

Install and align the brackets so the sensors will face each other across the garage door, with the beam no higher than 6" above the floor. They may be installed in one of three ways, as follows.

Garage door track installation (preferred):

- Slip the curved arms over the rounded edge of each door track, with the curved arms facing the door. Snap into place against the side of the track. It should lie flush, with the lip hugging the back edge of the track, as shown in Figure 1.

If your door track will not support the bracket securely, wall installation is recommended.

Wall installation:

- Place the bracket against the wall with curved arms facing the door. Be sure there is enough clearance for the sensor beam to be unobstructed.
- If additional depth is needed, an extension bracket (see Accessories) or wood blocks can be used.
- Use bracket mounting holes as a template to locate and drill (2) 3/16" diameter pilot holes on the wall at each side of the door, no higher than 6" above the floor.
- Attach brackets to wall with lag screws (not provided).
- If using extension brackets or wood blocks, adjust right and left assemblies to the same distance out from the mounting surface. Make sure all door hardware obstructions are cleared.

Floor installation:

- Use wood blocks or extension brackets (see Accessories) to elevate sensor brackets so the lenses will be no higher than 6" above the floor.
- Carefully measure and place right and left assemblies at the same distance out from the wall. Be sure all door hardware obstructions are cleared.
- Fasten to the floor with concrete anchors as shown.

Figure 1

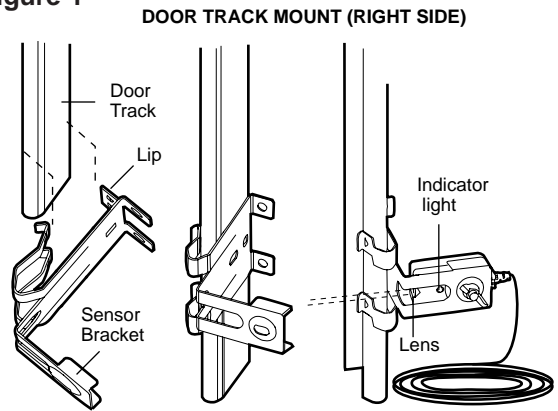

Figure 2

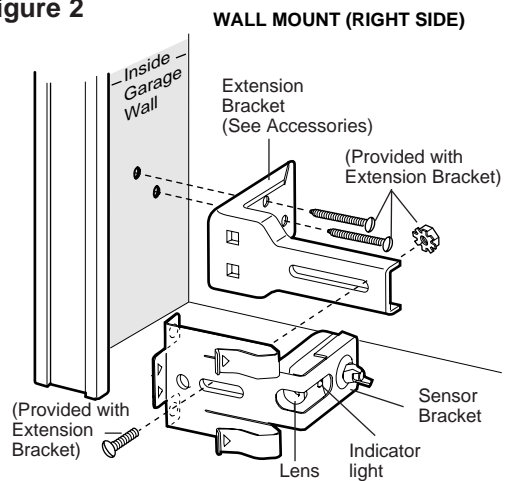
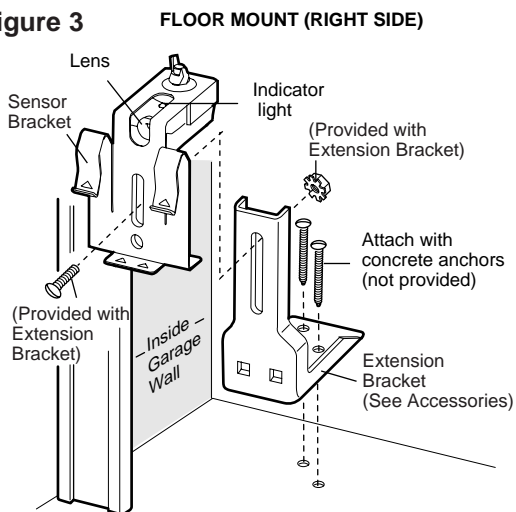
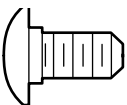

Figure 3



HARDWARE SHOWN ACTUAL SIZE



Carriage Bolt
1/4"-20x1/2" (2)

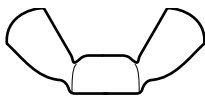

Wing Nut
1/4"-20 (2)

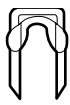

Insulated Staples (20)

MOUNTING AND WIRING THE SAFETY SENSORS

- Slide a 1/4"-20x1/2" carriage bolt into the slot on each sensor. Use wing nuts to fasten sensors to brackets, with lenses pointing toward each other across the door. Be sure the lens is not obstructed by a bracket extension. See Figure 4.
- Finger tighten the wing nuts.
- Run the wires from both sensors to the opener. Use insulated staples to secure wire to wall and ceiling.
- Strip 1/4" of insulation from each set of wires. Separate white and white/black wires sufficiently to connect to the opener terminal screws: white to 2 and white/black to 3. See Figure 5.

ALIGNING THE SAFETY SENSORS

- Plug in the opener. The indicator lights in both the sending and receiving eyes will *glow steadily* if wiring connections and alignment are correct.

The *sending* eye orange indicator light will glow regardless of alignment or obstruction. If the green indicator light in the *receiving* eye is off, dim, or flickering (and the invisible light beam path is not obstructed), alignment is required.

- Loosen the sending eye wing nut and readjust, aiming directly at the receiving eye. Lock in place.
- Loosen the receiving eye wing nut and adjust sensor until it receives the sender's beam. When the green indicator light glows steadily, tighten the wing nut.

Figure 4

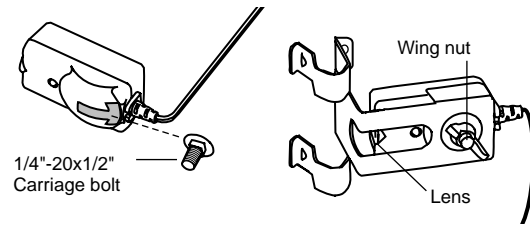

TROUBLESHOOTING THE SAFETY SENSORS

1. If the sending eye indicator light does not glow steadily after installation, check for:
 - Electric power to the opener.
 - A short in the white or white/black wires. These can occur at staples, or at screw terminal connections.
 - Incorrect wiring between sensors and opener.
 - A broken wire.
2. If the sending eye indicator light glows steadily but the receiving eye indicator light doesn't:
 - Check alignment.
 - Check for an open wire to the receiving eye.
3. If the receiving eye indicator light is dim, realign either sensor.

NOTE: When the invisible beam path is obstructed or misaligned while the door is closing, the door will reverse. If the door is already open, it will not close. The opener lights will blink 10 times. (If bulbs are not installed, 10 clicks can be heard.) See page 21.

Figure 5

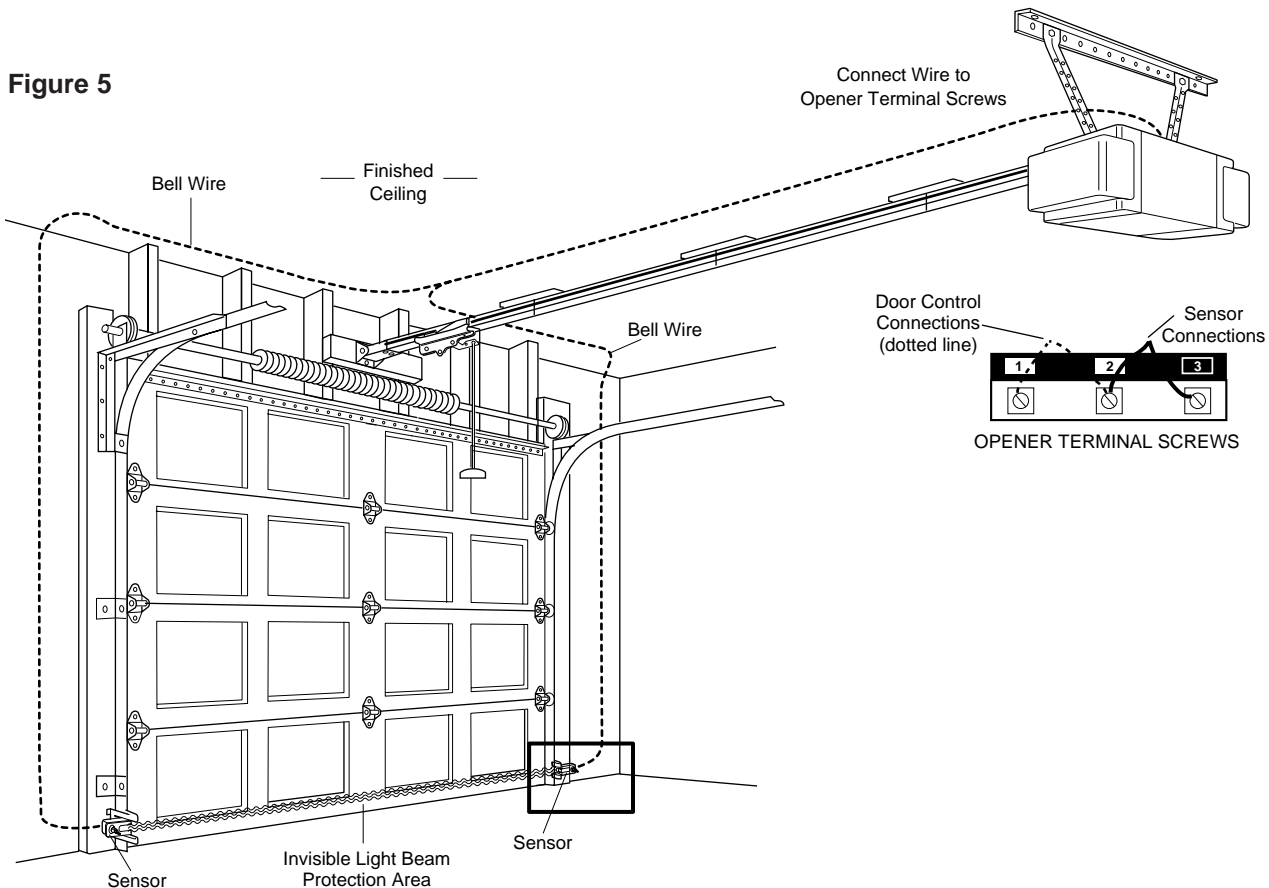

INSTALLATION STEP 11

Fasten the Door Bracket

Follow instructions which apply to your door type as illustrated below or on the following page.

A horizontal reinforcement brace should be long enough to be secured to two or three vertical supports. A vertical reinforcement brace should cover the height of the top panel.

Figure 1 shows one piece of angle iron as the horizontal brace. For the vertical brace, 2 pieces of angle iron are used to create a U-shaped support. The best solution is to check with your garage door manufacturer for an opener installation door reinforcement kit.

NOTE: Many door reinforcement kits provide for direct attachment of the clevis pin and door arm. In this case you will not need the door bracket; proceed to Step 12.

SECTIONAL DOORS

1. Center the door bracket on the previously marked vertical centerline used for the header bracket installation. Note correct UP placement, as stamped inside the bracket.
2. Position the top edge of the bracket 2"-4" below the top edge of the door, OR directly below any structural support across the top of the door.
3. Mark, drill holes and install as follows, depending on your door's construction:

Metal or light weight doors using a vertical angle iron brace between the door panel support and the door arm bracket:

- Drill 3/16" fastening holes. Secure the door bracket using the two 1/4"-14x5/8" self threading screws. (Figure 2A)
- Alternately, use two 5/16" bolts, lock washers and nuts (not provided). (Figure 2B)

Metal, insulated or light weight factory reinforced doors:

- Drill 3/16" fastening holes. Secure the door bracket using the self threading screws (Figure 3).

Wood Doors:

- Use top and bottom or side to side door bracket holes. Drill 5/16" holes through the door and secure bracket with 5/16"x2" carriage bolt, lock washer and nuts (not provided). (Figure 4)

NOTE: The 1/4"-14x5/8" self-threading screws are not intended for use on wood doors.

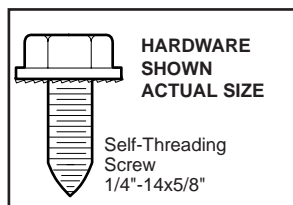

CAUTION

To prevent damage to garage door, reinforce inside of door with angle iron both vertically and horizontally.

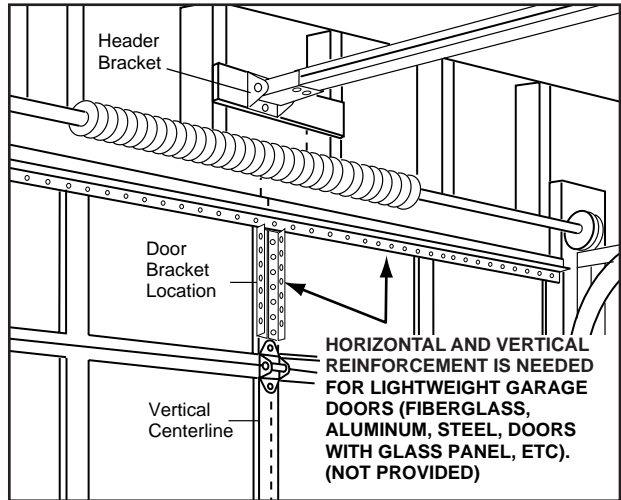

Figure 1

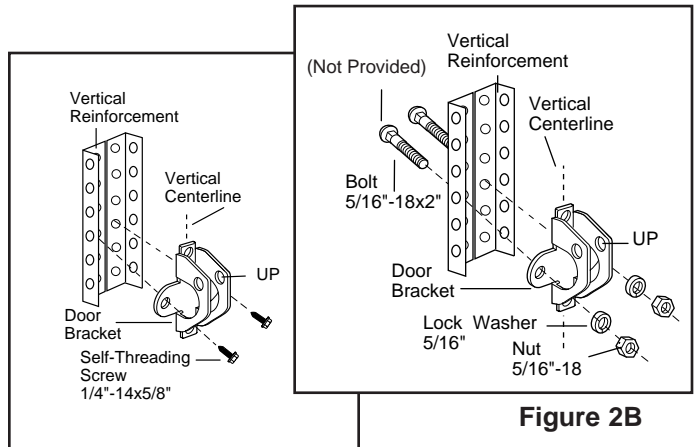

Figure 2A

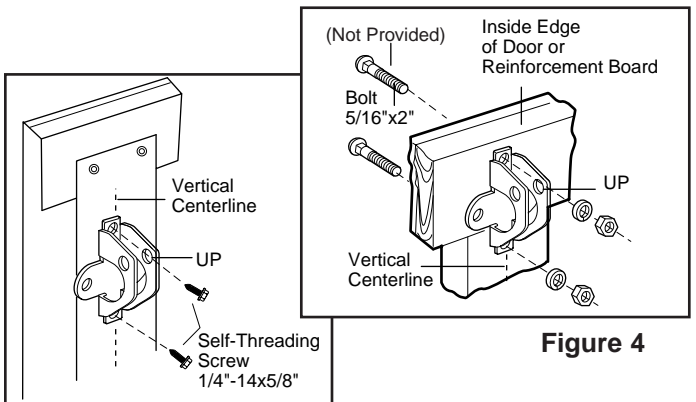

Figure 3

Figure 4

ONE-PIECE DOORS

Please read and comply with the warnings and reinforcement instructions on the previous page. They apply to one-piece doors also.

- Center the door bracket on the top of the door, in line with the header bracket as shown. Mark either the left and right, or the top and bottom holes.
- **Metal Doors:** Drill 3/16" pilot holes and fasten the bracket with the 1/4"x14x5/8" self-threading screws provided.
- **Wood Doors:** Drill 5/16" holes and use 5/16"x2" carriage bolts, lock washers and nuts (not provided) or 5/16"x1-1/2" lag screws (not provided) depending on your installation needs.

NOTE: The door bracket may be installed on the top edge of the door if required for your installation. (Refer to the dotted line optional placement drawing.)

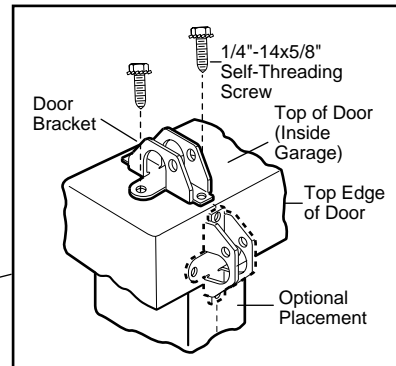
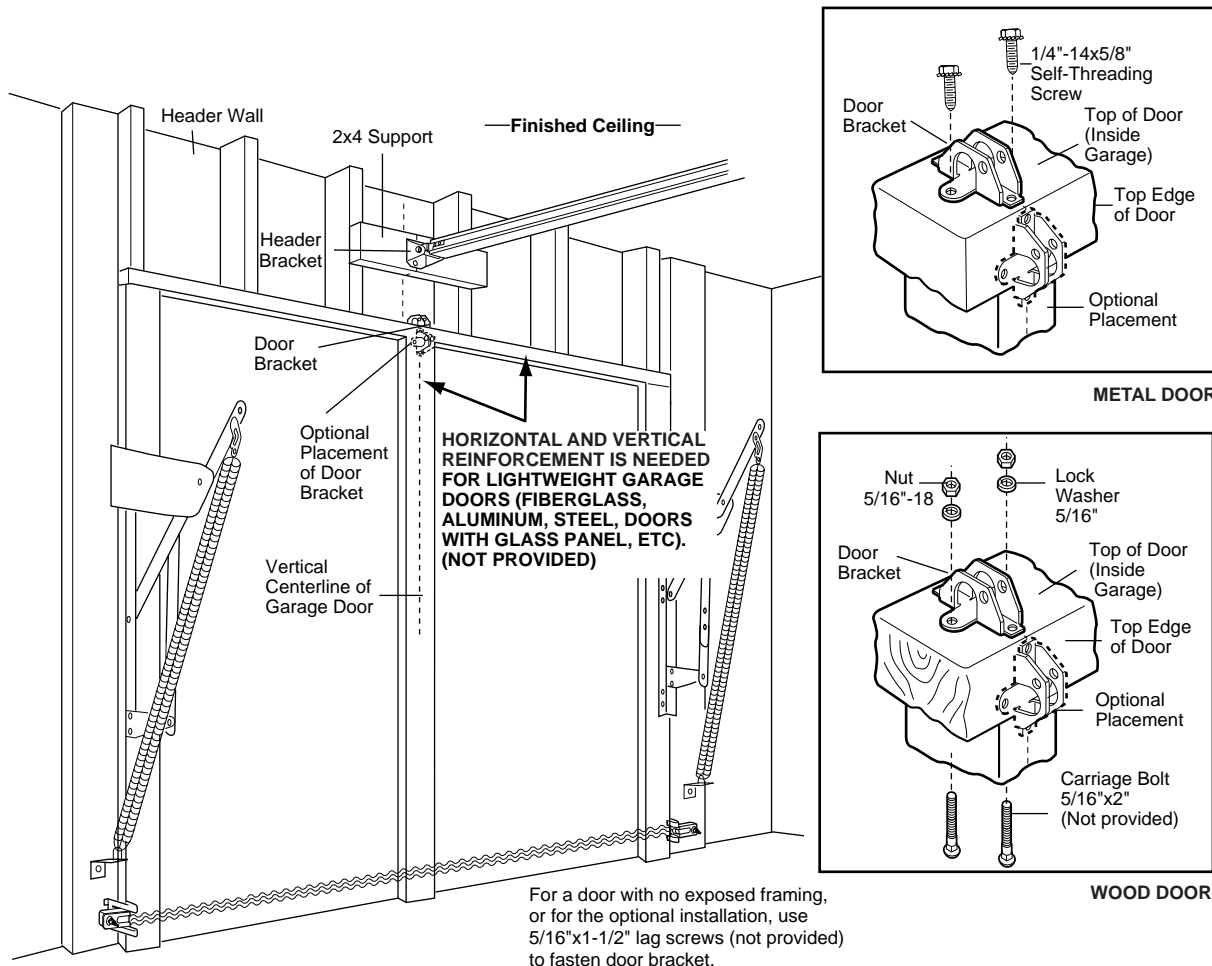
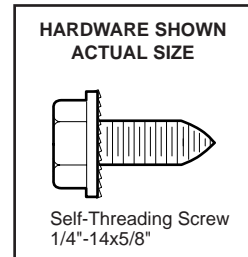

METAL DOOR

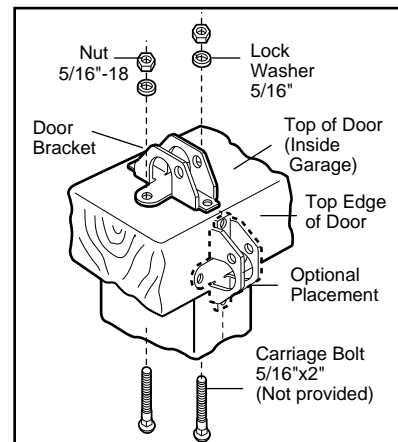

WOOD DOOR

INSTALLATION STEP 12

Connect Door Arm to Trolley

Follow instructions which apply to your door type as illustrated below and on the following page.

SECTIONAL DOORS ONLY

- Make sure garage door is fully closed. Pull the emergency release handle to disconnect the outer trolley from the inner trolley. Slide the outer trolley back (away from the door) about 2" as shown in Figures 1, 2 and 3.
- **Figure 1:**
 - Fasten straight door arm section to outer trolley with the 5/16"x1" clevis pin. Secure the connection with a ring fastener.
 - Fasten curved section to the door bracket in the same way, using the 5/16"x1-1/4" clevis pin.
- **Figure 2:**
 - Bring arm sections together. Find two pairs of holes that line up and join sections. Select holes as far apart as possible to increase door arm rigidity.
- **Figure 3, Hole alignment alternative:**
 - If holes in curved arm are above holes in straight arm, disconnect straight arm. Cut about 6" from the solid end. Reconnect to trolley with cut end down as shown.
 - Bring arm sections together.
 - Find two pairs of holes that line up and join with screws, lock washers and nuts.
- Proceed to Adjustment Step 1, page 28. Trolley will re-engage automatically when opener is operated.

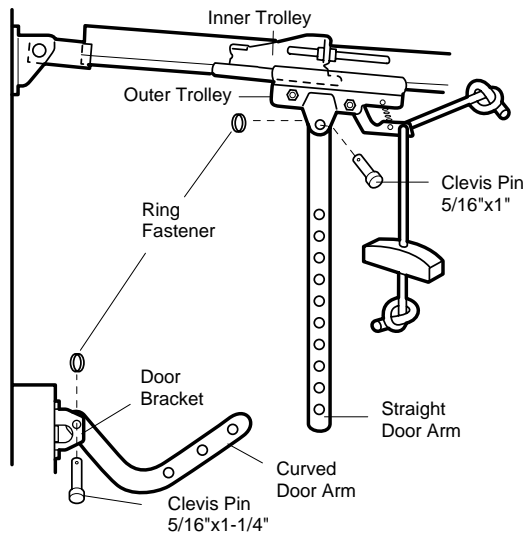

Figure 1

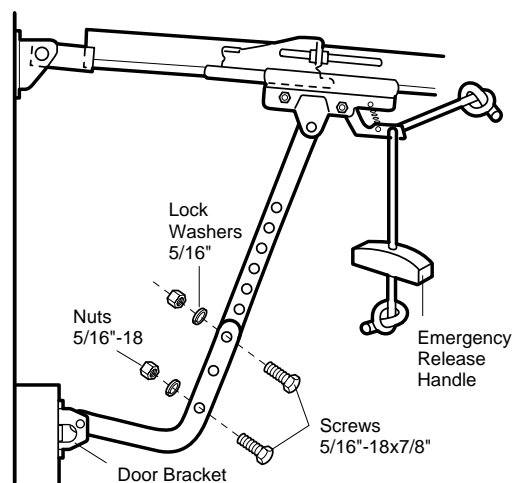

Figure 2

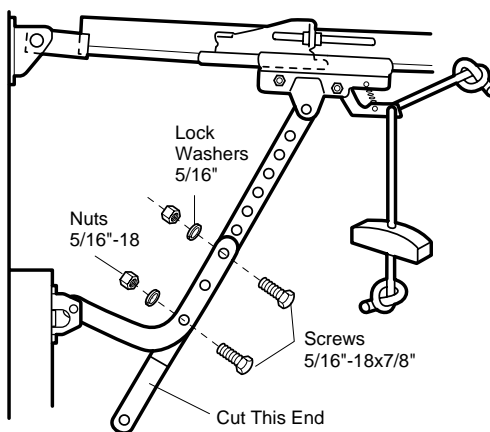
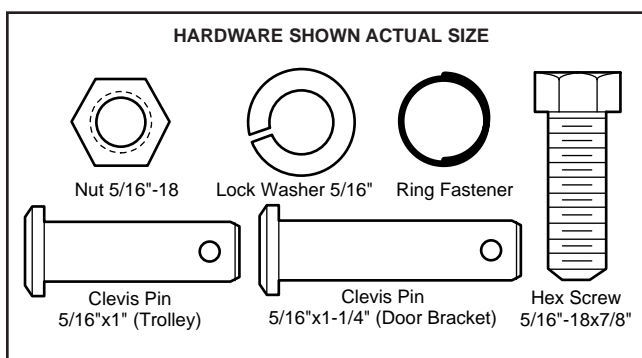

Figure 3

ALL ONE-PIECE DOORS

1. Assemble the door arm:

- Fasten the straight and curved door arm sections together to the longest possible length (with a 2 or 3 hole overlap).
- With the door closed, connect the straight door arm section to the door bracket with the 5/16"x1-1/4" clevis pin.
- Secure with a ring fastener.

2. Adjustment procedures:

On one-piece doors, before connecting the door arm to the trolley, the travel limits must be adjusted. Limit adjustment screws are located on the left side panel as shown on page 28. Follow adjustment procedures below.

• Open door adjustment: decrease UP travel limit

- Turn the UP limit adjustment screw counter-clockwise 5-1/2 turns.
- Press the Door Control push bar. The trolley will travel to the fully open position.
- Manually raise the door to the open position (parallel to the floor), and lift the door arm to the trolley. The arm should touch the trolley just in back of the door arm connector hole. Refer to the fully open trolley/door arm positions in the illustration. If the arm does not extend far enough, adjust the limit further. One full turn equals 2" of trolley travel.

• Closed door adjustment: decrease DOWN travel limit

- Turn the DOWN limit adjustment screw clockwise 5 complete turns.

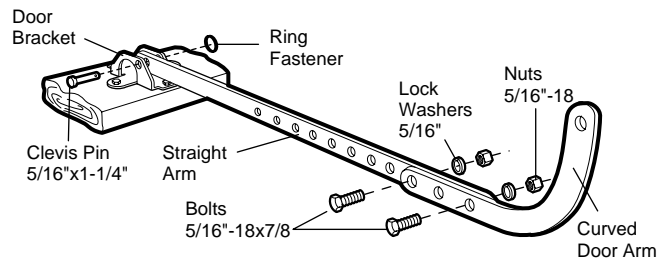

– Press the Door Control push bar. The trolley will travel to the fully closed position.

– Manually close the door and lift the door arm to the trolley. The arm should touch the trolley just ahead of the door arm connector hole. Refer to the fully closed trolley/door arm positions in the illustration. If the arm is behind the connector hole, adjust the limit further. One full turn equals 2" of trolley travel.

3. Connect the door arm to the trolley:

- Close the door and join the curved arm to the connector hole in the trolley with the remaining clevis pin. It may be necessary to lift the door slightly to make the connection.
- Secure with a ring fastener.
- Run the opener through a complete travel cycle. If the door has a slight "backward" slant in full open position as shown in the illustration, decrease the UP limit until the door is parallel to the floor.

NOTE: When setting the up limit on the following page, the door should not have a "backward" slant when fully open as illustrated below. A slight backward slant will cause unnecessary bucking an/or jerking operation as the door is being opened or closed from the fully open position.

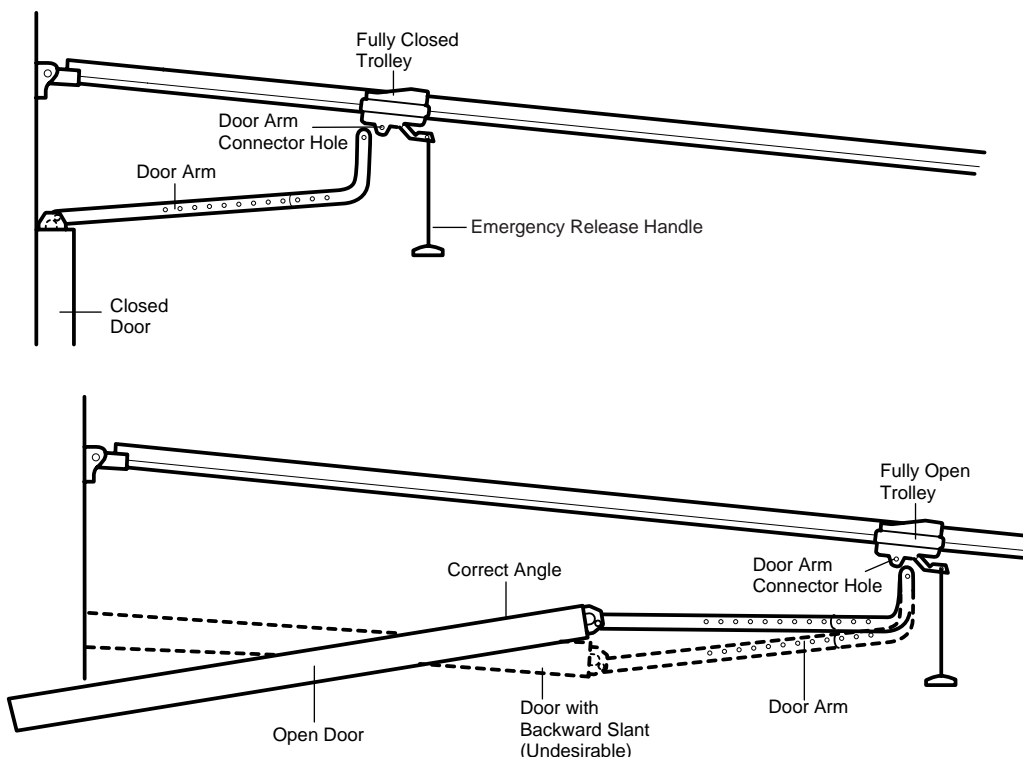

ADJUSTMENT STEP 1

Adjust the UP and DOWN Travel Limits

Limit adjustment settings regulate the points at which the door will stop when moving up or down.

To operate the opener, press the Door Control push bar. Run the opener through a complete travel cycle.

- Does the door open and close completely?
- Does the door stay closed and not reverse unintentionally when fully closed?

If your door passes both of these tests, no limit adjustments are necessary unless the reversing test fails (see Adjustment Step 3, page 30).

Adjustment procedures are outlined below. Read the procedures carefully before proceeding to Adjustment Step 2. Use a screwdriver to make limit adjustments. **Run the opener through a complete travel cycle after each adjustment.**

NOTE: Repeated operation of the opener during adjustment procedures may cause the motor to overheat and shut off. Simply wait 15 minutes and try again.

NOTE: If anything interferes with the door's upward travel, it will stop. If anything interferes with the door's downward travel (including binding or unbalanced doors), it will reverse.

HOW AND WHEN TO ADJUST THE LIMITS

- **If the door does not open completely but opens at least five feet:**

Increase up travel. Turn the UP limit adjustment screw clockwise. One turn equals 2" of travel.

NOTE: To prevent the trolley from hitting the cover protection bolt, keep a minimum distance of 2-4" between the trolley and the bolt.

- **If door does not open at least 5 feet:**

Adjust the UP (open) force as explained in Adjustment Step 2.

- **If the door does not close completely:**

Increase down travel. Turn the down limit adjustment screw counterclockwise. One turn equals 2" of travel.

If door still won't close completely and the trolley bumps into the pulley bracket (see page 4 or 5), try lengthening the door arm (page 26) and decreasing the down limit.

- **If the opener reverses in fully closed position:**

Decrease down travel. Turn the down limit adjustment screw clockwise. One turn equals 2" of travel.

⚠ WARNING

Without a properly installed safety reversal system, persons (particularly small children) could be **SERIOUSLY INJURED** or **KILLED** by a closing garage door.

- Incorrect adjustment of garage door travel limits will interfere with proper operation of safety reversal system.
- If one control (force or travel limits) is adjusted, the other control may also need adjustment.
- After any adjustments are made, the safety reversal system **MUST** be tested. Door **MUST** reverse on contact with one-inch high object (or 2x4 laid flat) on floor.

CAUTION

To prevent damage to vehicles, be sure fully open door provides adequate clearance.

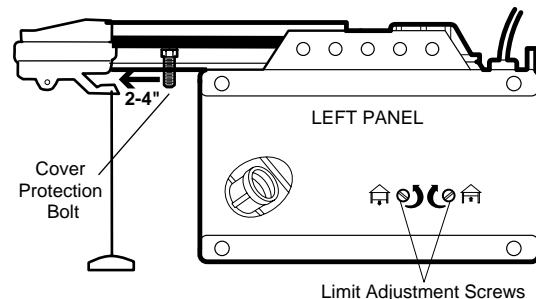

- **If the door reverses when closing and there is no visible interference to travel cycle:**

If the opener lights are flashing, the Safety Reversing Sensors are either not installed, misaligned, or obstructed. See Troubleshooting, page 23.

Test the door for binding: Pull the emergency release handle. Manually open and close the door. If the door is binding or unbalanced, call for a trained door systems technician. If the door is balanced and not binding, adjust the DOWN (close) force. See Adjustment Step 2.

ADJUSTMENT STEP 2

Adjust the Force

Force adjustment controls are located on the right panel of the motor unit. Force adjustment settings regulate the amount of power required to open and close the door.

If the forces are set too light, door travel may be interrupted by nuisance reversals in the down direction and stops in the up direction. Weather conditions can affect the door movement, so occasional adjustment may be needed.

The maximum force adjustment range is about 3/4 of a complete turn. Do not force controls beyond that point. Turn force adjustment controls with a screwdriver.

NOTE: *If anything interferes with the door's upward travel, it will stop. If anything interferes with the door's downward travel (including binding or unbalanced doors), it will reverse.*

HOW AND WHEN TO ADJUST THE FORCES

1. Test the DOWN (close) force

- Grasp the door bottom when the door is about halfway through DOWN (close) travel. The door should reverse. *Reversal halfway through down travel does not guarantee reversal on a one-inch obstruction. See Adjustment Step 3, page 30.* **If the door is hard to hold or doesn't reverse, DECREASE** the DOWN (close) force by turning the control counterclockwise. Make small adjustments until the door reverses normally. After each adjustment, run the opener through a complete cycle.
- **If the door reverses during the down (close) cycle and the opener lights aren't flashing, INCREASE** DOWN (close) force by turning the control clockwise. Make small adjustments until the door completes a close cycle. After each adjustment, run the opener through a complete travel cycle. *Do not increase the force beyond the minimum amount required to close the door.*

2. Test the UP (open) force

- Grasp the door bottom when the door is about halfway through UP (open) travel. The door should stop. **If the door is hard to hold or doesn't stop, DECREASE** UP (open) force by turning the control counterclockwise. Make small adjustments until the door stops easily and opens fully. After each adjustment, run the opener through a complete travel cycle.
- **If the door doesn't open at least 5 feet, INCREASE** UP (Open) force by turning the control clockwise. Make small adjustments until door opens completely. Readjust the UP limit if necessary. After each adjustment, run the opener through a complete travel cycle.

! WARNING

Without a properly installed safety reversal system, persons (particularly small children) could be **SERIOUSLY INJURED** or **KILLED** by a closing garage door.

- Too much force on garage door will interfere with proper operation of safety reversal system.
- **NEVER** increase force beyond minimum amount required to close garage door.
- **NEVER** use force adjustments to compensate for a binding or sticking garage door.
- If one control (force or travel limits) is adjusted, the other control may also need adjustment.
- After any adjustments are made, the safety reversal system **MUST** be tested. Door **MUST** reverse on contact with one-inch high object (or 2x4 laid flat) on floor.

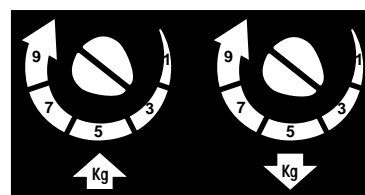
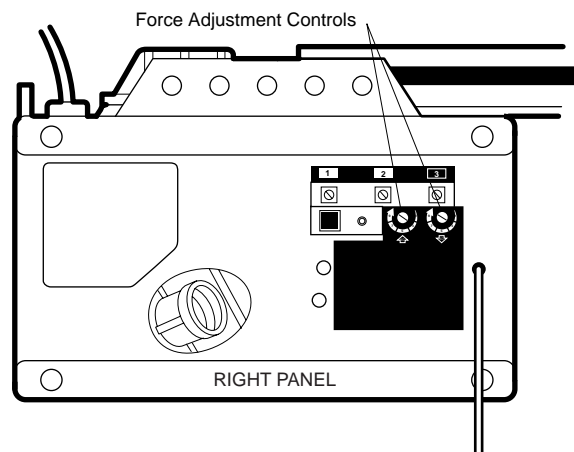

FORCE ADJUSTMENT LABEL

ADJUSTMENT STEP 3

Test the Safety Reversal System

TEST

- With the door fully open, place a one-inch board (or a 2x4 laid flat) on the floor, centered under the garage door.
- Operate the door in the down direction. The door **must** reverse on striking the obstruction.

ADJUST

- If the door stops on the obstruction, it is not traveling far enough in the down direction. Increase the DOWN limit by turning the DOWN limit adjustment screw counterclockwise 1/4 turn.
NOTE: On a sectional door, make sure limit adjustments do not force the door arm beyond a straight up and down position. See the illustration on page 26.
- Repeat the test.
- When the door reverses on the one-inch board, remove the obstruction and run the opener through 3 or 4 complete travel cycles to test adjustment.

IMPORTANT SAFETY CHECK:

Repeat Adjustment Steps 1, 2 and 3 after:

- Each adjustment of door arm length, limits, or force controls.
- Any repair to or adjustment of the garage door (including springs and hardware).
- Any repair to or buckling of the garage floor.
- Any repair to or adjustment of the opener.

ADJUSTMENT STEP 4

Test the Protector System®

- Press the remote control push button to open the door.
- Place the opener carton in the path of the door.
- Press the remote control push button to close the door. The door will not move more than an inch, and the opener lights will flash.

The garage door opener will not close from a remote if the indicator light in either sensor is off (alerting you to the fact that the sensor is misaligned or obstructed).

If the opener closes the door when the safety reversing sensor is obstructed (and the sensors are no more than 6" above the floor), call for a trained door systems technician.

⚠ WARNING

Without a properly installed safety reversal system, persons (particularly small children) could be **SERIOUSLY INJURED** or **KILLED** by a closing garage door.

- Safety reversal system **MUST** be tested every month.
- If one control (force or travel limits) is adjusted, the other control may also need adjustment.
- After **ANY** adjustments are made, the safety reversal system **MUST** be tested. Door **MUST** reverse on contact with one-inch high object (or 2x4 laid flat) on the floor.

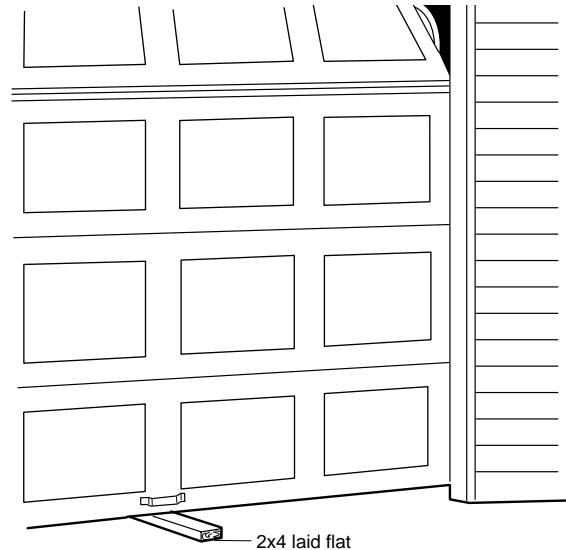

2x4 laid flat

⚠ WARNING

Without a properly installed safety reversing sensor, persons (particularly small children) could be **SERIOUSLY INJURED** or **KILLED** by a closing garage door.

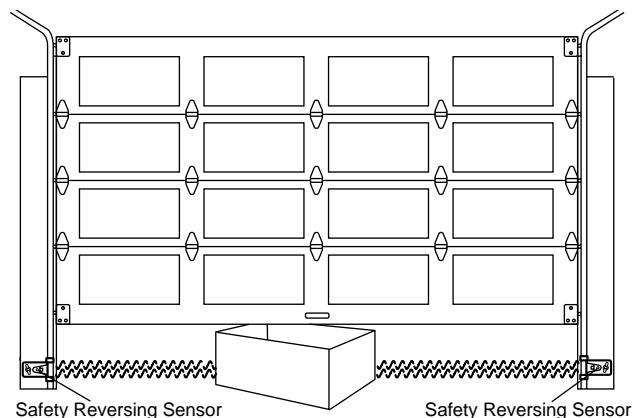

IMPORTANT SAFETY INSTRUCTIONS

WARNING

To reduce the risk of severe injury or death:

1. READ AND FOLLOW ALL WARNINGS AND INSTRUCTIONS.
2. ALWAYS keep remote controls out of reach of children. NEVER permit children to operate or play with garage door control push buttons or remote controls.
3. ONLY activate garage door when it can be seen clearly, it is properly adjusted, and there are no obstructions to door travel.
4. ALWAYS keep garage door in sight until completely closed. NO ONE SHOULD CROSS THE PATH OF THE MOVING DOOR.
5. If possible, use emergency release handle to disengage trolley ONLY when garage door is CLOSED. Weak or broken springs or unbalanced door could result in an open door falling rapidly and/or unexpectedly.
6. NEVER use emergency release handle unless garage doorway is clear of persons and obstructions.
7. NEVER use handle to pull garage door open or closed. If rope knot becomes untied, you could fall.
8. If one control (force or travel limits) is adjusted, the other control may also need adjustment.
9. After any adjustments are made, the safety reversal system MUST be tested.
10. Safety reversal system MUST be tested every month. Garage door MUST reverse on contact with one-inch high object (or a 2x4 laid flat) on the floor.
11. ALWAYS KEEP GARAGE DOOR PROPERLY BALANCED (see page 3). An improperly balanced door may not reverse when required and could result in severe injury or death.
12. All repairs to cables, spring assemblies and other hardware, all of which are under EXTREME tension, MUST be made by a trained door systems technician.
13. ALWAYS disconnect electric power to garage door opener before making any repairs or removing covers.
14. **SAVE THESE INSTRUCTIONS.**

Using Your Garage Door Opener

Your Security+ opener and hand-held remote control have been factory-set to a matching code which changes with each use, randomly accessing over 100 billion new codes. Your opener will operate with up to eight Security+ remote controls and one Security+ Keyless Entry System. If you purchase a new remote, or if you wish to deactivate any remote, follow the instructions in the *Programming* section.

Activate your opener with any of the following:

- *The hand-held Remote Control:* Hold the large push button down until the door starts to move.
- *The wall-mounted Door Control:* Hold the push button or bar down until the door starts to move.
- *The Keyless Entry (See Accessories):* If supplied with your garage door opener, it must be programmed before use. See *Programming*.

When the opener is activated (with the safety reversing sensor correctly installed and aligned)

1. If open, the door will close. If closed, it will open.
2. If closing, the door will reverse.
3. If opening, the door will stop.
4. If the door has been stopped in a partially open position, it will close.
5. If obstructed while closing, the door will reverse. If the obstruction interrupts the sensor beam, the opener lights will blink for five seconds.

6. If obstructed while opening, the door will stop.
7. If fully open, the door will not close when the beam is broken. The sensor has no effect in the opening cycle.

If the sensor is not installed, or is misaligned, the door won't close from a hand-held remote. However, you can close the door with the Door Control, the Outside Keylock, or Keyless Entry, *if you activate them until down travel is complete*. If you release them too soon, the door will reverse.

The opener lights will turn on under the following conditions: when the opener is initially plugged in; when power is restored after interruption; when the opener is activated.

They will turn off automatically after 4-1/2 minutes or provide constant light when the Light feature on the Multi-Function Door Control is activated. Bulb size is 75 watts maximum.

Security+ light feature: Lights will also turn on when someone walks through the open garage door. With a Multi-Function Door Control, this feature may be turned off as follows: With the opener lights off, press and hold the light button for 10 seconds, until the light goes on, then off again. To restore this feature, start with the opener lights on, then press and hold the light button for 10 seconds until the light goes off, then on again.

Using the Wall-Mounted Door Control

THE MULTI-FUNCTION DOOR CONTROL

Press the push bar to open or close the door. Press again to reverse the door during the closing cycle or to stop the door while it's opening.

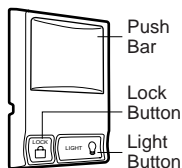

Light feature

Press the Light button to turn the opener light on or off. It will not control the opener lights when the door is in motion. If you turn it on and then activate the opener, the light will remain on for 4-1/2 minutes. Press again to turn it off sooner. The 4-1/2 minute interval can be changed to 1-1/2, 2-1/2, or 3-1/2 minutes as follows: Press and hold the Lock button until the light blinks (about 10 seconds). A single blink indicates that the timer is reset to 1-1/2 minutes. Repeat the procedure and the light will blink twice, resetting the timer to 2-1/2 minutes. Repeat again for a 3-1/2 minute interval, etc., up to a maximum of four blinks and 4-1/2 minutes.

Lock feature

Designed to prevent operation of the door from hand-held remote controls. However, the door will open and close from the Door Control, the Outside Keylock and the Keyless Entry Accessories.

To activate, press and hold the Lock button for 2 seconds. The push bar light will flash as long as the Lock feature is on.

To turn off, press and hold the Lock button again for 2 seconds. The push bar light will stop flashing. The Lock feature will also turn off whenever the "Smart" (learn) button on the motor unit panel is activated.

Additional feature when used with the Multi-Function hand-held remote

To control the opener lights:

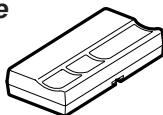

In addition to operating the door, you may program the remote to operate the lights.

1. With the door closed, press and hold a small remote button that you want to control the light.
2. Press and hold the Light button on the Multi-Function door control.
3. While holding the Light button, press and hold the Lock button on the door control.
4. After the opener lights flash, release all buttons.

To Open the Door Manually

⚠ WARNING

- To prevent possible **SERIOUS INJURY** or **DEATH** from a falling garage door:
 - If possible, use emergency release handle to disengage trolley **ONLY** when garage door is **CLOSED**. Weak or broken springs or unbalanced door could result in an open door falling rapidly and/or unexpectedly.
 - **NEVER** use emergency release handle unless garage doorway is clear of persons and obstructions.
- **NEVER** use handle to pull door open or closed. If rope knot becomes untied, you could fall.

The door should be fully closed if possible. Pull down on the emergency release handle and lift the door manually. To reconnect the door to the opener, press the door control push bar.

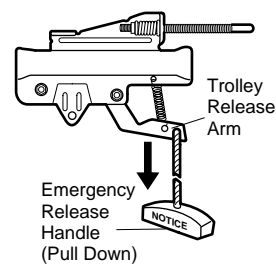

MANUAL DISCONNECT POSITION

The *lockout feature* prevents the trolley from reconnecting automatically. Pull the emergency release handle down and back (toward the opener). The door can then be raised and lowered manually as often as necessary. To disengage the lockout feature, pull the handle straight down. The trolley will reconnect on the next UP or DOWN operation.

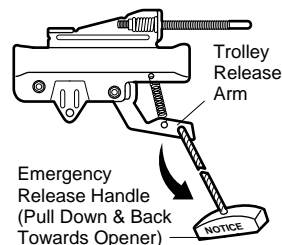

LOCKOUT POSITION

Care of Your Opener

LIMIT AND FORCE ADJUSTMENTS:

Weather conditions may cause some minor changes in door operation requiring some readjustments, particularly during the first year of operation.

Pages 28 and 29 refer to the limit and force adjustments. Only a screwdriver is required. Follow the instructions carefully.

Repeat the safety reverse test (page 30) after any adjustment of limits or force.



LIMIT CONTROLS
(Left side panel)

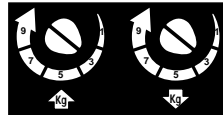

FORCE CONTROLS
(Right side panel)

MAINTENANCE SCHEDULE

Once a Month

- Manually operate door. If it is unbalanced or binding, call a trained door systems technician.
- Check to be sure door opens & closes fully. Adjust limits and/or force if necessary. (See pages 28 and 29.)
- Repeat the safety reverse test. Make any necessary adjustments. (See page 30.)

Once a Year

- Oil door rollers, bearings and hinges. The opener does not require additional lubrication. Do not grease the door tracks.

THE REMOTE CONTROL BATTERY

⚠ WARNING

To prevent possible **SERIOUS INJURY** or **DEATH**:

- NEVER allow small children near batteries.
- If battery swallowed, immediately notify doctor.

The lithium battery should produce power for up to 5 years. To replace battery, use the visor clip or screwdriver blade to pry open the case as shown. Insert battery positive side up.

Dispose of old battery properly.

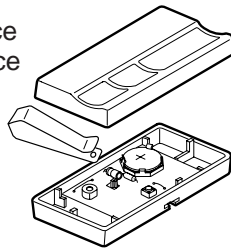

NOTICE: To comply with FCC and or Industry Canada rules, adjustment or modifications of this receiver and/or transmitter are prohibited, except for changing the code setting or replacing the battery. THERE ARE NO OTHER USER SERVICEABLE PARTS.

Tested to Comply with FCC Standards FOR HOME OR OFFICE USE. Operation is subject to the following two conditions: (1) this device may not cause harmful interference, and (2) this device must accept any interference received, including interference that may cause undesired operation.

Having a Problem?

1. **The opener doesn't operate from either the Door Control or the remote control:**

- Does the opener have electric power? Plug a lamp into the outlet. If it doesn't light, check the fuse box or the circuit breaker. (Some outlets are controlled by a wall switch.)
- Have you disabled all door locks? Review installation instruction warnings on page 11.
- Is there a build-up of ice or snow under the door? The door may be frozen to the ground. Remove any restriction.
- The garage door spring may be broken. Have it replaced.
- Repeated operation may have tripped the overload protector in the motor. Wait 15 minutes and try again.

2. **Opener operates from the remote, but not from the Door Control:**

- Is the door control lit? If not, remove the bell wire from the motor unit terminals. Short the red and white terminals by touching both terminals at the same time with a piece of wire. If the opener runs, check for a faulty wire connection at the door control, a short under the staples, or a broken wire.
- Are the wiring connections correct? Review *Installation Step 6*, page 18.

3. **The door operates from the Door Control, but not from the remote control:**

- Is the door push bar flashing? If your model has the Lock feature, make sure it is off.
- Program the opener to match the remote control code. (Refer to instructions on the motor unit panel.) Repeat with all remotes.

4. **The remote control has short range:**

- Change the location of the remote control in your car.
- Check to be sure the antenna on the side or back panel of motor unit extends fully downward.
- Some installations may have shorter range due to a metal door, foil backed insulation, or metal garage siding.

5. **Opener noise is disturbing in living quarters of home:**

- If operational noise is a problem because of proximity of the opener to the living quarters, the Vibration Isolator Kit 41A3263 can be installed. This kit was designed to minimize vibration to the house and is easy to install.

Having a Problem? (Continued)

6. The garage door opens and closes by itself:

- Be sure that all remote control push buttons are off.
- Remove the bell wire from the door control terminals and operate from the remote only. If this solves the problem, the door control is faulty (replace), or there is an intermittent short on the wire between the door control and the motor unit.
- Clear memory and re-program all remote controls.

7. The door doesn't open completely:

- Is something obstructing the door? Is it out of balance, or are the springs broken? Remove the obstruction or repair the door.
- If the door is in good working order but now doesn't open all the way, increase the up force. See *Adjustment Step 2*.
- If the door opens at least 5 feet, the travel limits may need to be increased. One turn equals 2 inches of travel. See *Adjustment Step 1*.

Repeat the safety reverse test after the adjustment is complete.

8. The door stops but doesn't close completely:

- Review the travel limits adjustment procedures on page 28.

Repeat the safety reverse test after any adjustment of door arm length, close force or down limit.

9. The door opens but won't close:

- If the opener lights blink, check the safety reversing sensor. See *Installation Step 10*.
- If the opener lights don't blink and it is a new installation, check the down force. See *Adjustment Step 2*, page 29. For an existing installation, see below.

Repeat the safety reverse test after the adjustment is complete.

10. The door reverses for no apparent reason and opener lights don't blink:

- Is something obstructing the door? Pull the emergency release handle. Operate the door manually. If it is unbalanced or binding, call a trained door systems technician.
- Clear any ice or snow from the garage floor area where the door closes.
- Review *Adjustment Step 2* on page 29.
- If door reverses in the fully closed position, decrease the travel limits (*Adjustment Step 1*).

Repeat safety reverse test after adjustments to force or travel limits. The need for occasional adjustment of the force and limit settings is normal. Weather conditions in particular can affect door travel.

11. The door reverses for no apparent reason and opener lights blink for 5 seconds after reversing:

- Check the safety reversing sensor. Remove any obstruction or align the receiving eye. See *Installation Step 10*.

12. The opener lights don't turn on:

- Replace the light bulbs (75 watts maximum). Use a standard neck garage door opener bulb if regular bulb burns out.

13. The opener lights don't turn off:

- Is the Light feature on? Turn it off.

14. The opener strains or maximum force is needed to operate door:

- The door may be out of balance or the springs may be broken. **Close the door** and use the emergency release handle to disconnect the trolley. Open and close the door manually. A properly balanced door will stay in any point of travel while being supported entirely by its springs. If it does not, disconnect the opener and call a trained door systems technician. **Do not increase the force to operate the opener.**

15. The opener motor hums briefly, then won't work:

- The garage door springs may be broken. See above.
- If the problem occurs on the first operation of the opener, door may be locked. Disable the door lock.

Repeat the safety reverse test after the adjustment is complete.

16. The opener won't operate due to power failure:

- Use the emergency release handle to disconnect the trolley. The door can be opened and closed manually. When power is restored, press the Door Control push bar and trolley will automatically reconnect (unless trolley is in lockout position.) See page 32.
- The Outside Quick Release accessory (for use on garages with no service door) disconnects the trolley from outside the garage in case of power failure.

PROGRAMMING

Your garage door opener has already been programmed at the factory to operate with your hand-held remote control. The door will open and close when you press the large push button.

Below are instructions for programming your opener to operate with additional Security+ remote controls.

To Add an Additional Hand-held Remote Control

USING THE "LEARN" BUTTON

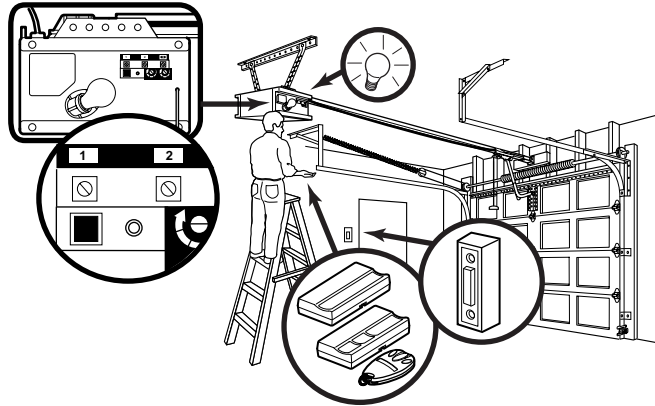

1. Press and release the "learn" button on the motor unit. The learn indicator light will glow steadily for 30 seconds.

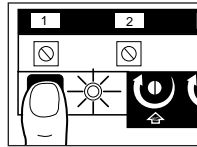

2. Within 30 seconds, press and hold the button on the hand-held remote* that you wish to operate your garage door.

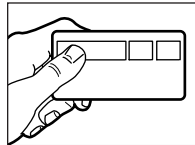

3. Release the button when the motor unit lights blink. It has learned the code. If light bulbs are not installed, two clicks will be heard.

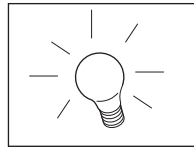

USING THE MULTI-FUNCTION DOOR CONTROL

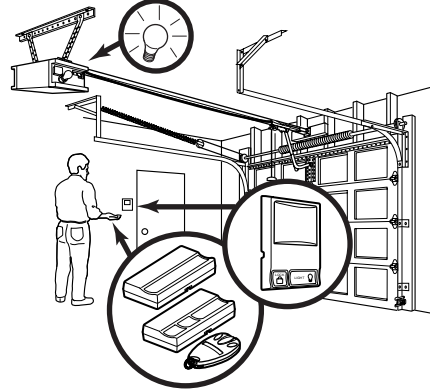

1. Press and hold the button on the hand-held remote* that you wish to operate your garage door.

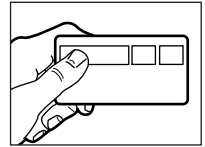

2. While holding the remote button, press and hold the LIGHT button on the Multi-Function Door Control.



3. Continue holding both buttons while you press the push bar on the Multi-Function Door Control (all three buttons are held).

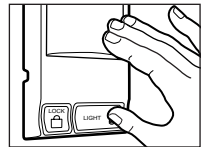

4. Release buttons when the motor unit lights blink. It has learned the code. If light bulbs are not installed, two clicks will be heard.

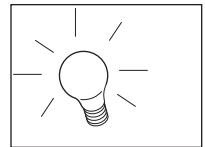

To Erase All Codes From Motor Unit Memory

To deactivate any unwanted remote, first erase all codes:

Press and hold "learn" button on motor unit until the learn indicator light goes out (approximately 6 seconds). All previous codes are now erased. Reprogram each remote or keyless entry you wish to use.

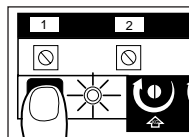

*Multi-Function Remotes

If supplied with your garage door opener, the large button is factory programmed to operate it. Additional buttons on any Security+ multi-function remote or mini-remote can be programmed to operate other Security+ garage door openers.

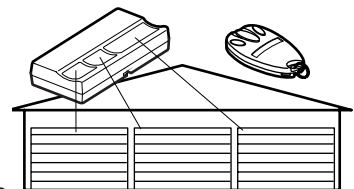

To Add or Change a Keyless Entry PIN

Note: Your new Keyless Entry must be programmed to operate your garage door opener.

USING THE "LEARN" BUTTON

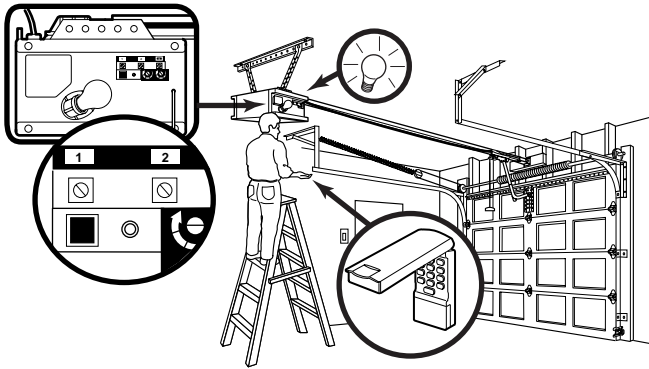

1. Press and release the "learn" button on motor unit. The learn indicator light will glow steadily for 30 seconds.
2. Within 30 seconds, enter a four digit personal identification number (PIN) of your choice on the keypad. Then press and hold the ENTER button.
3. Release the button when the motor unit lights blink. It has learned the code. If light bulbs are not installed, two clicks will be heard.

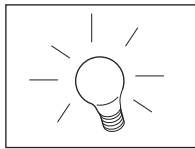
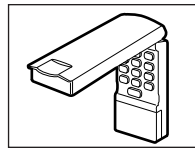
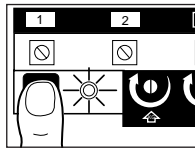

To change an existing, known PIN

If the existing PIN is known, it may be changed by one person without using a ladder.

1. Press the four buttons for the present PIN, then press and hold the # button.
The opener light will blink twice. Release the # button.

2. Press the new 4-digit PIN you have chosen, then press Enter.

The motor unit lights will blink once when the PIN has been learned.

Test by pressing the new PIN, then press Enter. The door should move.

To set a temporary PIN

You may authorize access by visitors or service people with a temporary 4-digit PIN. After a programmed number of hours or number of accesses, this temporary PIN expires and will no longer open the door. It can be used to *close* the door even after it has expired. To set a temporary PIN:

1. Press the four buttons for your personal entry PIN (not the last temporary PIN), then press and hold the * button.

The opener light will blink three times. Release the button.

USING THE MULTI-FUNCTION DOOR CONTROL

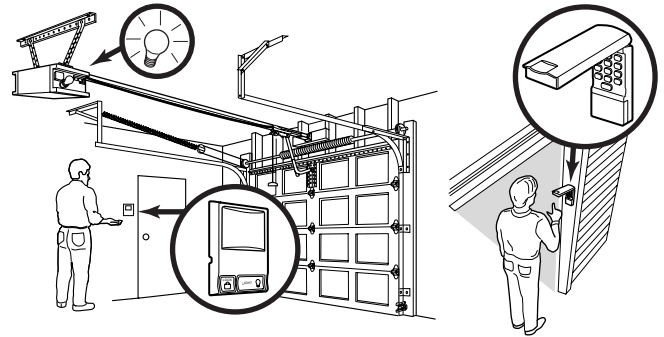

NOTE: This method requires two people if the Keyless Entry is already mounted outside the garage.

1. Enter a four digit personal identification number (PIN) of your choice on the keypad. Then press and hold ENTER.

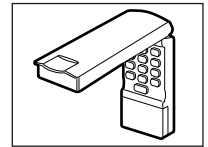

2. While holding the ENTER button, press and hold the LIGHT button on the Multi-Function Door Control.

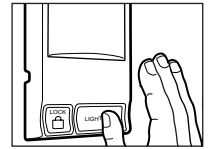

3. Continue holding the ENTER and LIGHT buttons while you press the push bar on the Multi-Function Door Control (all three buttons are held).



4. Release buttons when the motor unit lights blink. It has learned the code. If light bulbs are not installed, two clicks will be heard.

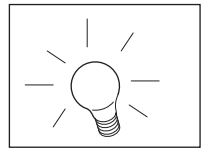

2. Press the temporary 4-digit PIN you have chosen, then press Enter.

The opener light will blink four times.

3. To set the number of **hours** this temporary PIN will work, press the number of hours (up to 255), then press *.

OR

3. To set the number of **times** this temporary PIN will work, press the number of times (up to 255), then press #.

The opener light will blink once when the temporary PIN has been learned.

Test by pressing the four buttons for the temporary PIN, then press Enter. The door should move. If the temporary PIN was set to a certain number of openings, remember that the test has used up one opening. To clear the temporary password, repeat steps 1-3, setting the number of hours or times to 0 in step 3.

REPAIR PARTS

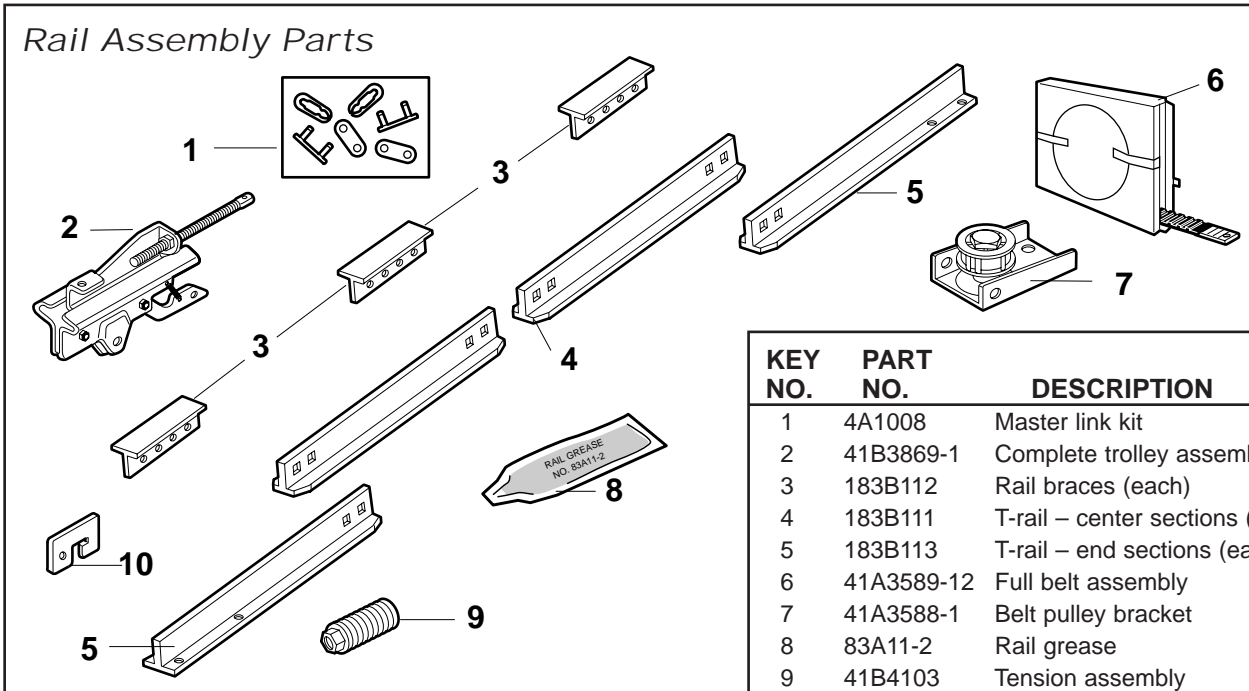

KEY NO.	PART NO.	DESCRIPTION
1	4A1008	Master link kit
2	41B3869-1	Complete trolley assembly
3	183B112	Rail braces (each)
4	183B111	T-rail – center sections (each)
5	183B113	T-rail – end sections (each)
6	41A3589-12	Full belt assembly
7	41A3588-1	Belt pulley bracket
8	83A11-2	Rail grease
9	41B4103	Tension assembly (Spring/Trolley Nut)
10	109B33	Trolley Clip
		NOT SHOWN
	41A2848	Rail assembly hardware kit (see page 7).

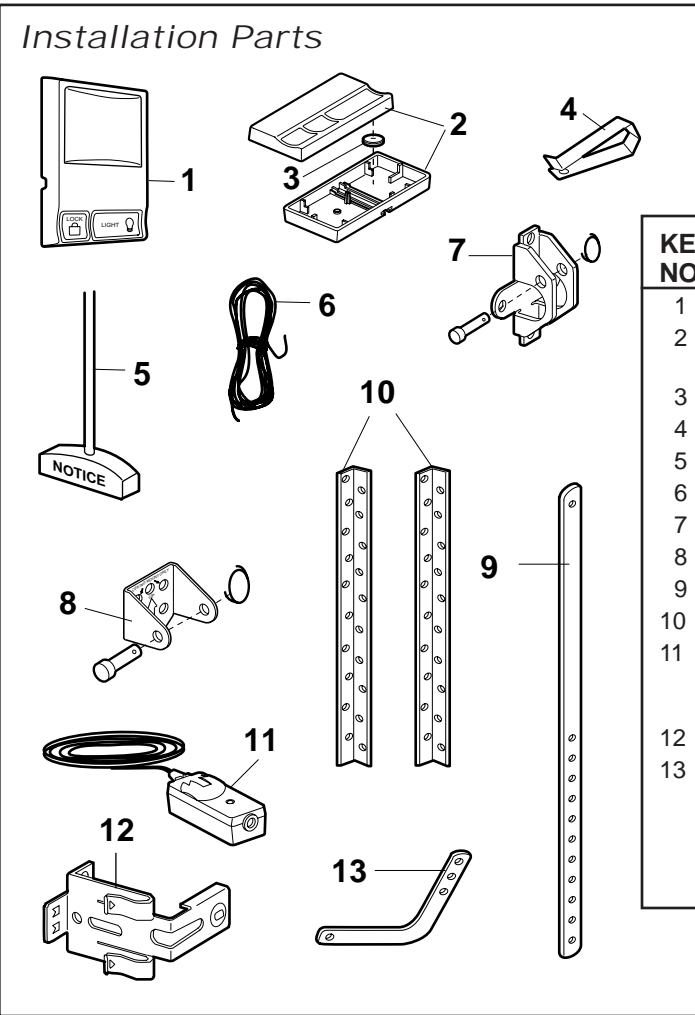

KEY NO.	PART NO.	DESCRIPTION
1	41A5273-8	Multi-function door control panel
2	41A5056-10	Multi-function remote control housing only (no circuit board)
3	10A20	3V2032 Lithium battery
4	29B137	Transmitter visor clip
5	41A2828	Manual release rope & handle assembly
6	217A238	2-conductor bell wire – white & white/red
7	41A5047-1	Door bracket w/clevis pin & fastener
8	41A4353-1	Header bracket w/clevis pin & fastener
9	178B34	Straight door arm section
10	12B350	Hanging brackets
11	41A5034	Safety sensor kit (receiving and sending eyes) with 3' 2-conductor bell wire attached
12	41A5266-1	Safety sensor brackets (2)
13	178B35	Curved door arm section
		NOT SHOWN
	41A4437-10	Installation hardware bag (see page 7).
	114A2126	Owner's manual

Motor Unit Assembly Parts

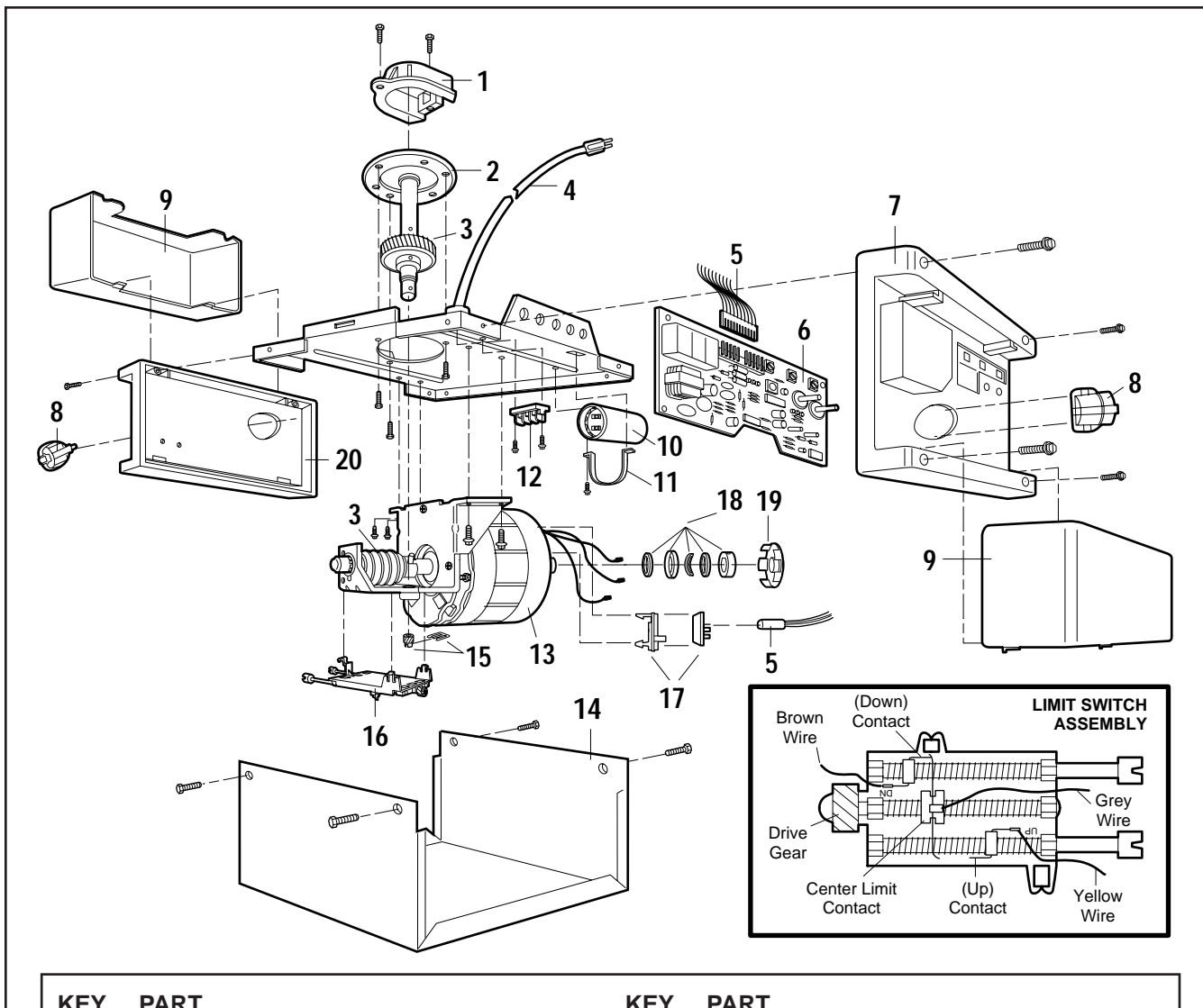

KEY NO.	PART NO.	DESCRIPTION	KEY NO.	PART NO.	DESCRIPTION
1	41A4371	Belt cap retainer	10	30B363	Capacitor – 1/2 h.p.
2	41A4885-2	Gear and sprocket assy., Complete with: Spring washer; Thrust washer; Retaining ring; Bearing plate; Roll pins (2); Drive gear and worm gear; Helical gear w/retainer and grease	11	12A373	Capacitor bracket
3	41A2817	Drive/worm gear kit w/grease, Roll pins (2)	12	41D3150	Terminal block w/screws
4	41B4245	Line cord	13	41C4842	Universal replacement motor & bracket assembly, Complete with: Motor, worm, bracket, bearing assembly, RPM sensor.
5	41C4876	Wire harness assembly with plug	14	41A3583-6	Cover
6	41A5021-5E	Receiver logic board assembly, Complete with Logic board	15	41A2818	Helical gear & retainer w/grease
7	41A4888	End panel w/all labels	16	41D3452	Limit switch assembly
8	175B88M	Light socket	17	41C4398A	RPM sensor assembly
9	108D34	Lens	18	41A2826	Shaft bearing kit
			19	41A2822A	Interrupter cup assembly
			20	41A4889	End panel
				41A2825	NOT SHOWN Opener assembly hardware kit (includes screws not designated by a number in illustration.)

ACCESSORIES

953CB

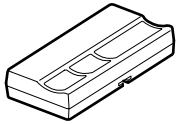

SECURITY+ Multi-Function Remote Control:

Includes visor clip.

956CB



SECURITY+ Multi-Function Mini Remote Control:

With key ring and Velcro fastening strip.

945CB

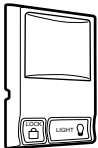

Multi-Function Door Control Panel:

Provides a Lock Feature which prevents operation of garage door opener from portable remotes and a Light Feature for constant light.

935CB



Motion Detecting Control Panel:

Multi-function door control with motion sensor that automatically turns opener lights on for 5 minutes when it detects a person entering the garage. Sensor can be easily deactivated when desired.

940CB

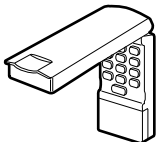

SECURITY+ Keyless Entry:

Enables homeowner to operate garage door opener from outside by entering a password on a specially designed keyboard. Also can add a temporary password for visitors or service persons. This temporary password can be limited to a programmable number of hours or entries.

7702CB

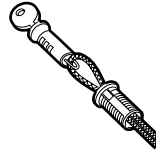

Outside Quick Release:

Required for a garage with NO access door.

760CB

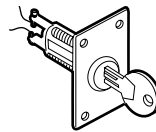

Outside Keylock:

Opens the garage door automatically from outside when remote control is not handy.

8704CB

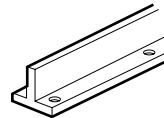

8 Foot Rail Extension Kit:

To allow an 8 foot door to open fully.

41A5281

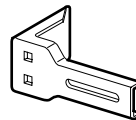

Extension Brackets:

(Optional) For safety sensor installation onto the wall or floor.
To order call: 1-800-528-9131

CHAMBERLAIN SERVICE IS ON CALL

OUR LARGE SERVICE ORGANIZATION
SPANS AMERICA

INSTALLATION AND SERVICE INFORMATION IS AS
NEAR AS YOUR TELEPHONE SIX DAYS A WEEK.
SIMPLY DIAL OUR TOLL FREE NUMBER:

1-800-528-9131

www.chamberlain-diy.com

HOURS: (Central Std. Time)

6 A.M. to 7 P.M. Monday through Friday

8 A.M. to 6 P.M. Saturday

For professional installation, parts and service,
contact your local CHAMBERLAIN dealer. Look for him
in the Yellow Pages, or call our Service number for a
list of dealers in your area.

HOW TO ORDER REPAIR PARTS

Selling prices will be furnished on request, or parts will
be shipped at prevailing prices and you will be billed
accordingly.

WHEN ORDERING REPAIR PARTS, ALWAYS GIVE
THE FOLLOWING INFORMATION:

- PART NUMBER
- PART NAME
- MODEL NUMBER

ADDRESS ORDERS TO:

THE CHAMBERLAIN GROUP, INC.

Technical Support Group
6020 S. Country Club Road
Tucson, Arizona 85706

SERVICE INFORMATION

TOLL FREE NUMBER:

1-800-528-9131

CHAMBERLAIN GARAGE DOOR OPENER ONE-YEAR LIMITED WARRANTY

The Chamberlain Group, Inc. ("Seller") warrants to the first retail purchaser of this product, for the residence in which this product is originally installed, that it is free from any defect in materials and/or workmanship for a period of one year from the date of purchase. Additionally, the motor and belt are warranted for the lifetime of the product. The product must be used in complete accordance with Chamberlain's instructions for installation, operation, and care. **The proper operation of this product is dependent on your compliance with the Owner's Manual Instructions regarding installation, operation, maintenance and testing. Failure to comply strictly with those instructions will void this warranty in its entirety. Please note that the safety reverse system, in order to operate properly with your garage door, must be adjusted and periodically tested in accordance with the Owner's Manual.**

If, during the limited warranty period, it appears as though this product contains a defect which is covered by this limited warranty, **call our toll free service number, before dismantling this product, at 1-800-528-9131.** Then send this product, pre-paid and insured, to our service center for warranty repair. You will be advised of shipping instructions when you call the toll free service number. Please include a brief description of the problem and a dated proof-of-purchase receipt with any product that is returned for warranty repair.

Products returned to Seller for warranty repair, which upon receipt by Seller are confirmed to be defective and covered by this limited warranty, will be repaired or replaced (at Seller's sole option) at no cost to you and returned pre-paid. Defective parts will be repaired or replaced with new or factory-rebuilt parts at Seller's sole option.

THIS LIMITED WARRANTY IS IN LIEU OF ANY OTHER WARRANTIES, EXPRESS OR IMPLIED, INCLUDING ANY IMPLIED WARRANTY OF MERCHANTABILITY OR FITNESS FOR A PARTICULAR PURPOSE, OR OTHERWISE, AND OF ANY OTHER OBLIGATIONS OR LIABILITY ON SELLER'S PART. THIS LIMITED WARRANTY DOES NOT COVER NON-DEFECT DAMAGE, DAMAGE CAUSED BY IMPROPER INSTALLATION, OPERATION OR CARE (INCLUDING, BUT NOT LIMITED TO ABUSE, MISUSE, FAILURE TO PROVIDE REASONABLE AND NECESSARY MAINTENANCE, OR ANY ALTERATIONS TO THIS PRODUCT), LABOR CHARGES FOR DISMANTLING OR REINSTALLING A REPAIRED OR REPLACED UNIT, REPLACEMENT OF BATTERIES AND LIGHT BULBS, OR UNITS INSTALLED FOR NON-RESIDENTIAL USE.

THIS LIMITED WARRANTY DOES NOT COVER ANY PROBLEMS WITH, OR RELATING TO, THE GARAGE DOOR OR GARAGE DOOR HARDWARE, INCLUDING BUT NOT LIMITED TO THE DOOR SPRINGS, DOOR ROLLERS, DOOR ALIGNMENT AND HINGES. ANY SERVICE CALL THAT DETERMINES THE PROBLEM HAS BEEN CAUSED BY ANY OF THESE ITEMS COULD RESULT IN A FEE TO YOU.

UNDER NO CIRCUMSTANCES SHALL SELLER BE LIABLE FOR CONSEQUENTIAL, INCIDENTAL OR SPECIAL DAMAGES ARISING IN CONNECTION WITH THE USE OF, OR INABILITY TO USE, THIS PRODUCT. IN NO EVENT SHALL SELLER'S LIABILITY FOR BREACH OF WARRANTY, BREACH OF CONTRACT, NEGLIGENCE OR STRICT LIABILITY EXCEED THE COST OF THE PRODUCT COVERED HEREBY. NO PERSON IS AUTHORIZED TO ASSUME FOR US ANY OTHER LIABILITY IN CONNECTION WITH THE SALE OF THIS PRODUCT.

Some states do not allow the exclusion or limitation of consequential, incidental or special damages, so the above limitation or exclusion may not apply to you. This limited warranty gives you specific legal rights, and you may also have other rights which vary from state to state.

LIMITED WARRANTY ON MOTOR & BELT - MODEL 8200 Series

The motor and belt are fully warranted for the lifetime of the product to the first-time purchaser.