

The Chamberlain Group, Inc.
A DUCHOSSOIS ENTERPRISE
845 Larch Avenue
Elmhurst, Illinois 60126-1196

Complies with UL 325
Regulations effective
January 1, 1993.



MODEL CSO – 1/2HP COMMERCIAL STRENGTH OPERATOR

**For Residential and Light Duty Commercial Use
Install on Sectional Doors Only**

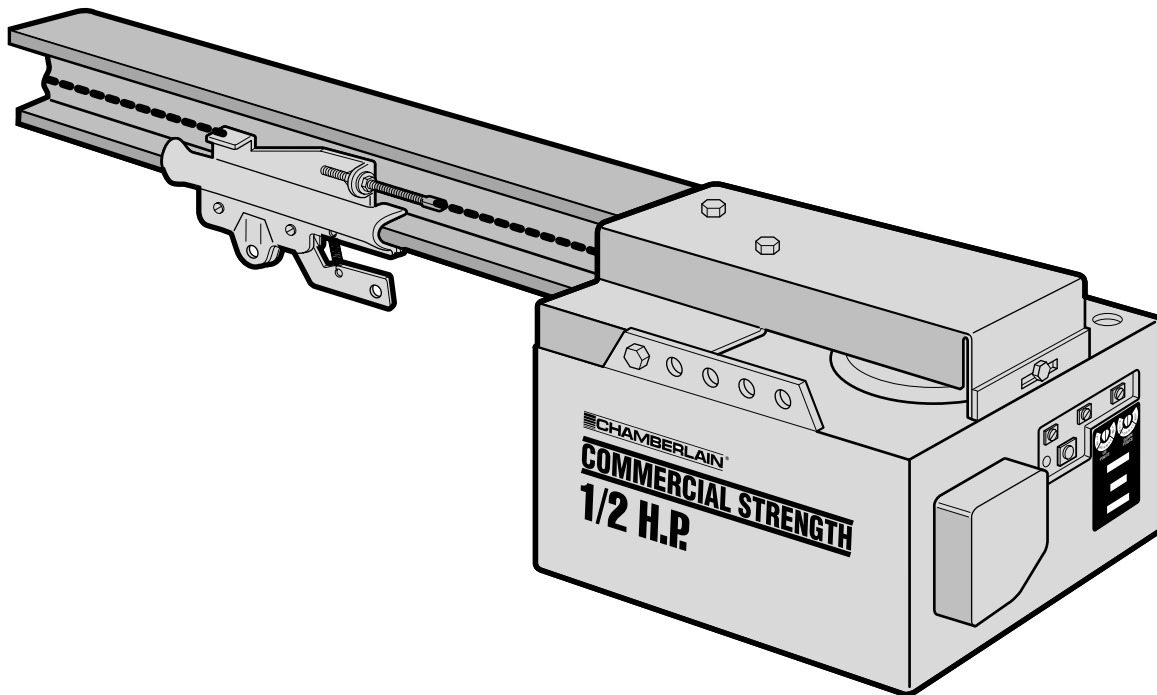

OWNER'S MANUAL

- Please read this manual and the enclosed safety materials carefully!
- Fasten the manual near the garage door after installation.
- The door WILL NOT CLOSE unless the Protector System® is connected and properly aligned.
- Periodic checks of the opener are required to ensure safe operation.
- The model number label is located on the front end panel of your opener as shown.

| Contents | Page | Contents | Page |
|--|------|--|--------|
| A review of safety alert symbols..... | 2 | Attach manual release rope and handle..... | 17 |
| You'll need tools..... | 3 | Electrical requirements..... | 18 |
| Safety information..... | 3 | The Protector System®..... | 19 |
| Testing your garage door for sticking, binding and balance..... | 3 | Install the safety reversing sensor..... | 20, 21 |
| Illustration of sectional door installation..... | 4 | Fasten door bracket and plate..... | 22 |
| Carton inventory..... | 5 | Connect door arm to trolley..... | 23 |
| Hardware inventory..... | 6 | Adjustment section – pages 24 - 26 | |
| Assembly section – pages 7 - 10 | | Travel limit adjustments..... | 24 |
| Assemble rail..... | 7 | Force adjustments..... | 25 |
| Attach chain pulley bracket..... | 7 | Test the Protector System®..... | 26 |
| Install trolley..... | 8 | Test the safety reverse system..... | 26 |
| Fasten rail to power head..... | 8 | Operation safety instructions..... | 27 |
| Install chain..... | 9 | Care of your opener..... | 27 |
| Attach rail support bracket..... | 9 | Maintenance schedule..... | 27 |
| Tighten the chain..... | 10 | Operation of your opener..... | 28 |
| Installation section – pages 10 - 23 | | Receiver and remote control programming..... | 29 |
| Installation safety instructions..... | 10 | Having a problem?..... | 30, 31 |
| Determine header bracket location..... | 11 | Repair parts, rail assembly..... | 32 |
| Install the header bracket..... | 12 | Repair parts, installation..... | 32 |
| Attach the rail to header bracket..... | 13 | Repair parts, opener assembly..... | 33 |
| Position the opener..... | 14 | Accessories..... | 34 |
| Hang the opener..... | 15 | Index..... | 35 |
| Install the door control..... | 16 | How to order repair parts..... | 36 |
| Install the light..... | 17 | Warranty..... | 36 |

Start by reviewing these important safety alert symbols

When you see these safety symbols on the following pages, they will alert you to the possibility of *serious injuries or death* if you do not comply with the corresponding instructions. The hazard may come from something mechanical or from electric shock. *Read the instructions carefully.*



WARNING

Mechanical



WARNING

Electrical

When you see this safety symbol on the following pages, it will alert you to the possibility of damage to your garage door and/or the garage door opener if you do not comply with the corresponding instructions. *Read the instructions carefully.*



CAUTION

This garage door opener is designed and tested to offer safe service provided it is installed, operated, maintained and tested in strict accordance with the safety instructions contained in this manual.

You'll Need Tools

During assembly, installation and adjustment of the opener, instructions will call for hand tools shown below.

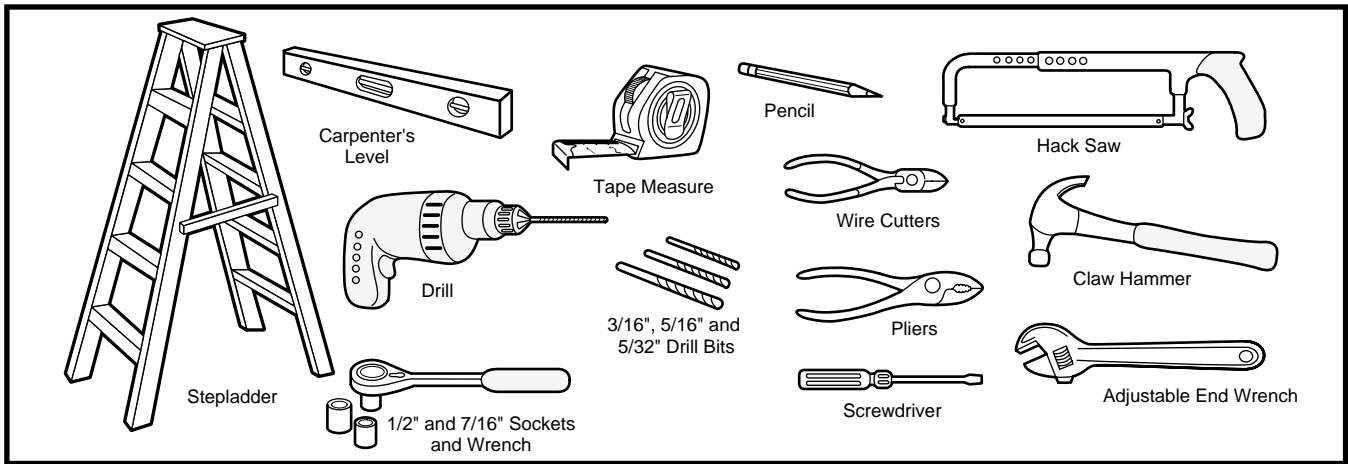

WARNING

An unbalanced garage door might not reverse when required and someone under the door could be seriously injured or killed.

If your garage door binds, sticks or is out of balance, call for professional garage door service. *Garage doors, door springs, cables, pulleys, brackets and their hardware, are under extreme tension and can cause serious injury or death. Do not try to loosen, move or adjust them yourself!*

Ropes left on a garage door could cause someone to become entangled and killed. Remove all ropes connected to the door before installing and operating the opener.

This product is for use on sectional garage doors only. Serious personal injury could result from the use of this product on



CAUTION

To avoid damage to the garage door and opener, disable locks before installing and operating the opener. Use a wood screw or nail to hold locks in the "open" (unlocked) position.

Operation at other than 120V 60 Hz will cause opener malfunction and damage.

Identify the type and height of your door, any special conditions that exist, and any additional materials that may be required by referring to the list on page 4.

Before you begin, complete the following test to make sure your door is balanced, and is not sticking or binding:

- Lift the door about halfway as shown. Release the door. It should stay in place, supported entirely by its springs.
- Raise and lower the door to see if there is any

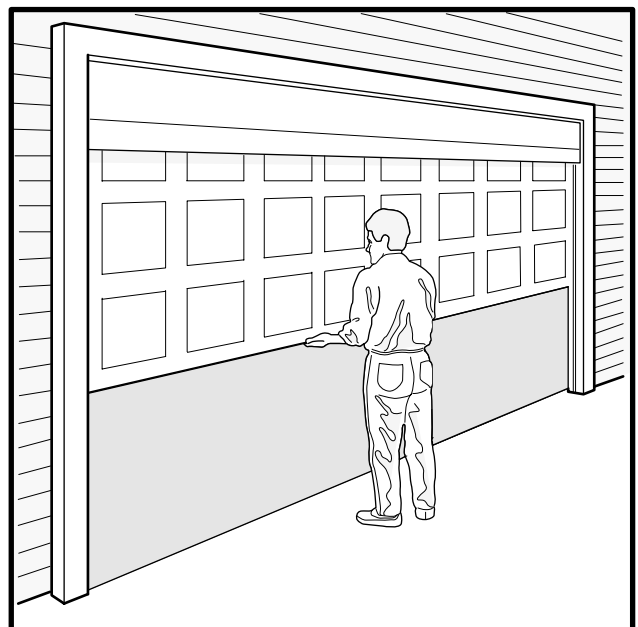

Before you begin, survey your garage area. Do any of the following conditions apply to you?

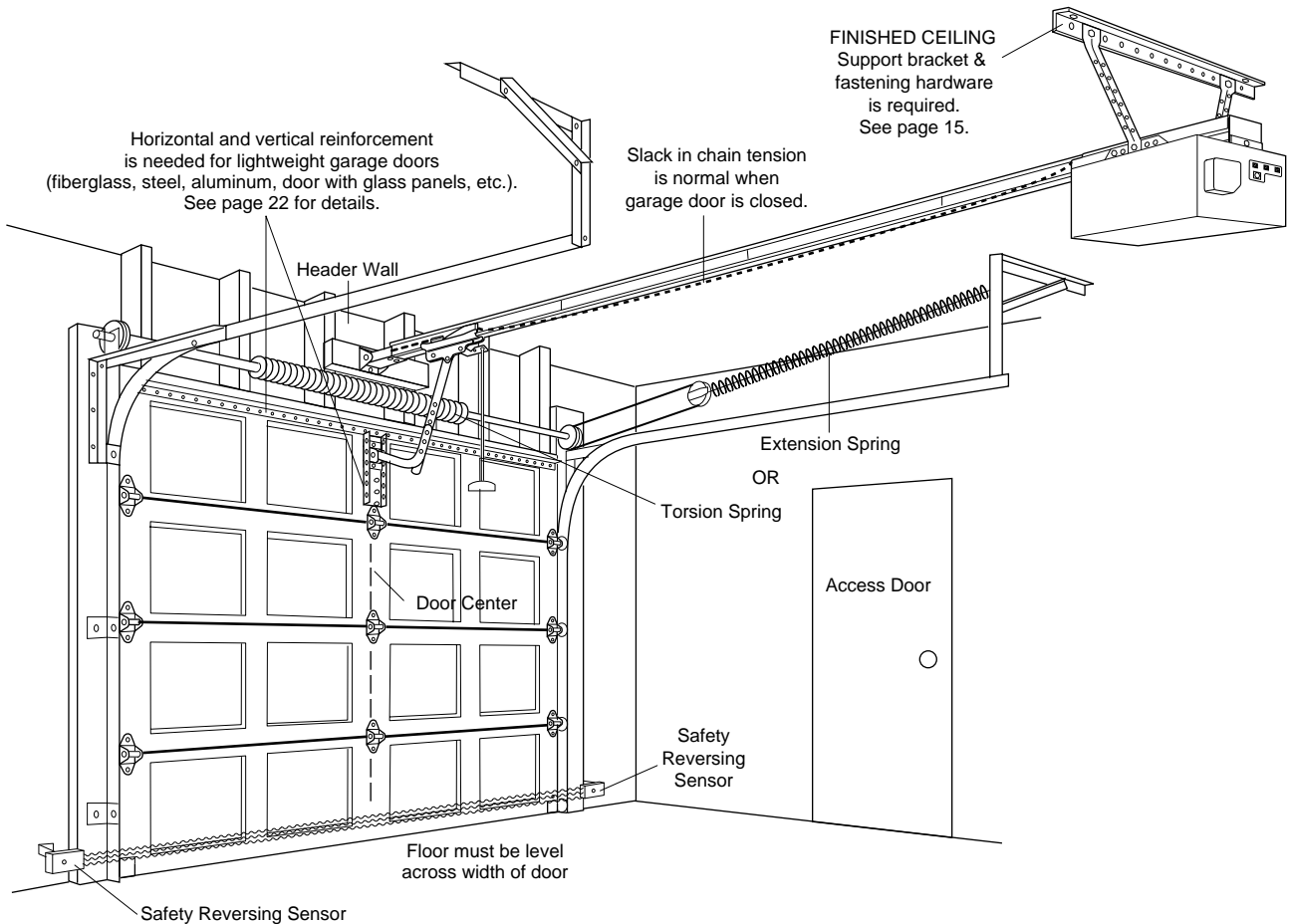

Based on your particular requirements, there are several installation steps which might call for materials and/or hardware not included in the carton.

- Step 1, page 11 - Look at the wall or ceiling above the garage door. The header bracket *must* be securely fastened to structural supports.
- Step 5, page 15 - Do you have a finished ceiling in your garage? If so, a support bracket and additional fastening hardware may be required.
- Safety reversing sensor, page 19 - Depending upon garage construction, wood blocks may need to be fastened to mounting locations before sensors are installed.
- Step 10, page 20 - Alternate floor mounting of the safety reversing sensor will require hardware not provided.
- Step 11, page 22 - Do you have a steel, aluminum, fiberglass or glass panel door? If so, horizontal and vertical reinforcement is required.
- Look at the garage door where it meets the floor. It must close on the floor all the way across. Otherwise, the safety reverse system may not work properly. See page 26. Floor or door should be repaired.

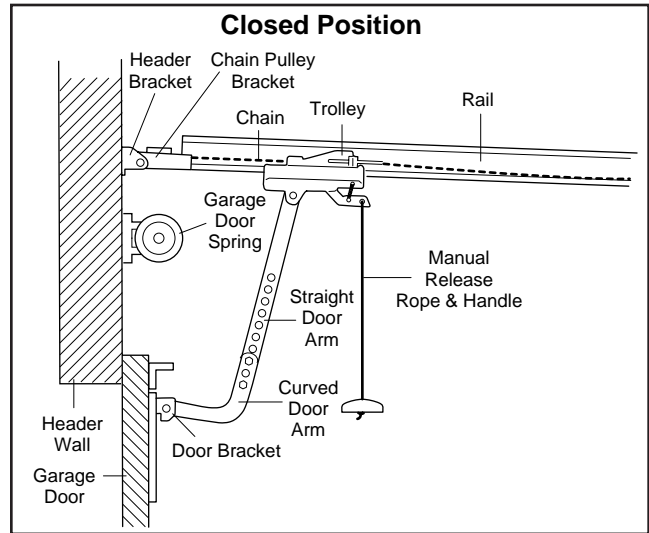

- The opener can be installed within 2 feet to the left or right of the door center if there is a torsion spring or center bearing plate in the way of the header bracket or door bracket area. If your door has extension springs, the opener *must* be installed in the center of the door. See pages 11 and 22.

Do you have an access door in addition to the garage door? If not, Model 7702CB Outside Quick Release is required. See page 34.

You may find it helpful to refer back to this page as you proceed with the installation of your opener.

Carton Inventory

Your garage door opener is packaged in two cartons which contain all parts illustrated below. If anything is missing, carefully check the packing material. Parts may be "stuck" in the foam. Hardware for assembly and installation is listed below.

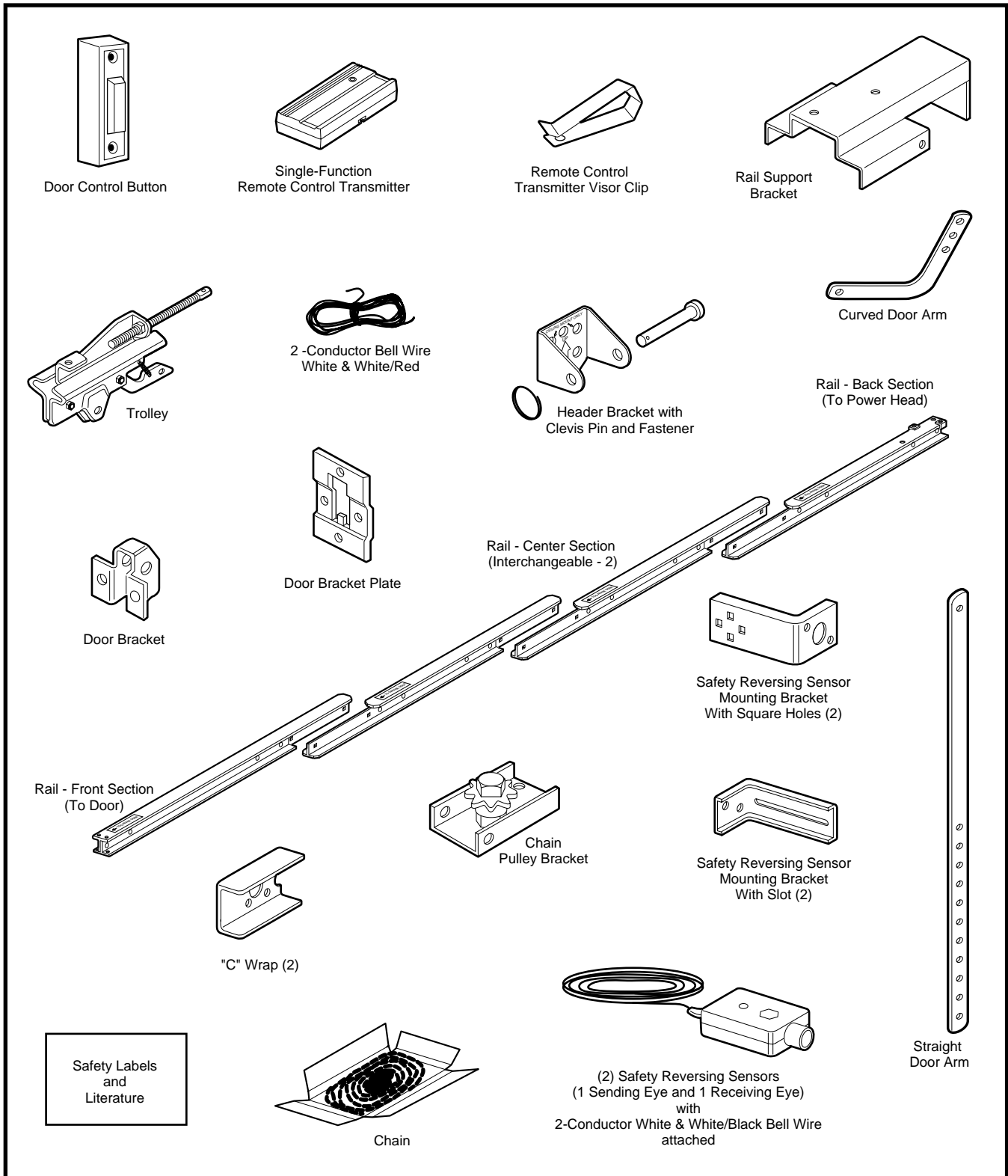

Group all hardware found in all packages contained in the rail and opener cartons into the three kits illustrated below.

Assembly Hardware

Hex Screw 1/4"-20x5/8" (2)

Washed Screw 5/16"-18x1/2" (4) (2 -mounted in opener)

Carriage Bolt 1/4"-20x1/2" (7)

Screw #8-32x3/8" (1)

Lock Washer 1/4" (2)

Master Link (2)

Hex Screw 5/16"-18x7/8" (3)

Trolley Threaded Shaft (1)

Lock Washer 5/16" (4)

Nut 5/16"-18 (5)

Lock Nut 1/4"-20 (7)

Installation Hardware

Hex Screw 5/16"-18x7/8" (4)

Handle

Rail Grease

Lag Screw 5/16"-9x1-5/8" (4)

Nut 5/16"-18 (6)

Lock Washer 5/16" (6)

Rope

Carriage Bolt 5/16"-18x2-1/2" (2)

Screw 6ABx1-1/2" (2)

Dry Wall Anchors (2)

Clevis Pin 5/16"x2-3/4" (1)

Insulated Staples (10)

Clevis Pin 5/16"x1" (2)

Ring Fastener (3)

Safety Reversing Sensor Installation Hardware

Lag Screw 1/4x1-1/2" (4)

Carriage Bolt 1/4"-20x1/2" (4)

Lock Nut 1/4"-20 (4)

Wing Nut (2)

Hex Screw 1/4-20x1-1/2" (2)

Screw #10-32x3/8" (4)

Lock Nut #10x32 (4)

Insulated Staples (20)

Assembly Section: Pages 7 – 10

To avoid installation difficulties, do not run the garage door opener until instructed to do so.

Assembly Step 1

Assemble the Rail & Attach the Chain Pulley Bracket

- Align the 4 rail sections on a flat surface exactly as shown. Center sections are interchangeable. Front and back sections are not. Be sure the arrow labels are pointing toward the door.
- Insert the carriage bolts so the square bolt necks seat in the square holes in the rail sections and pass through the square holes in the opposing rail sections. Assemble lock nuts, ensure alignment and tighten.

If rail is not assembled exactly as shown, trolley will not travel smoothly along length of rail or it will hit against nuts.

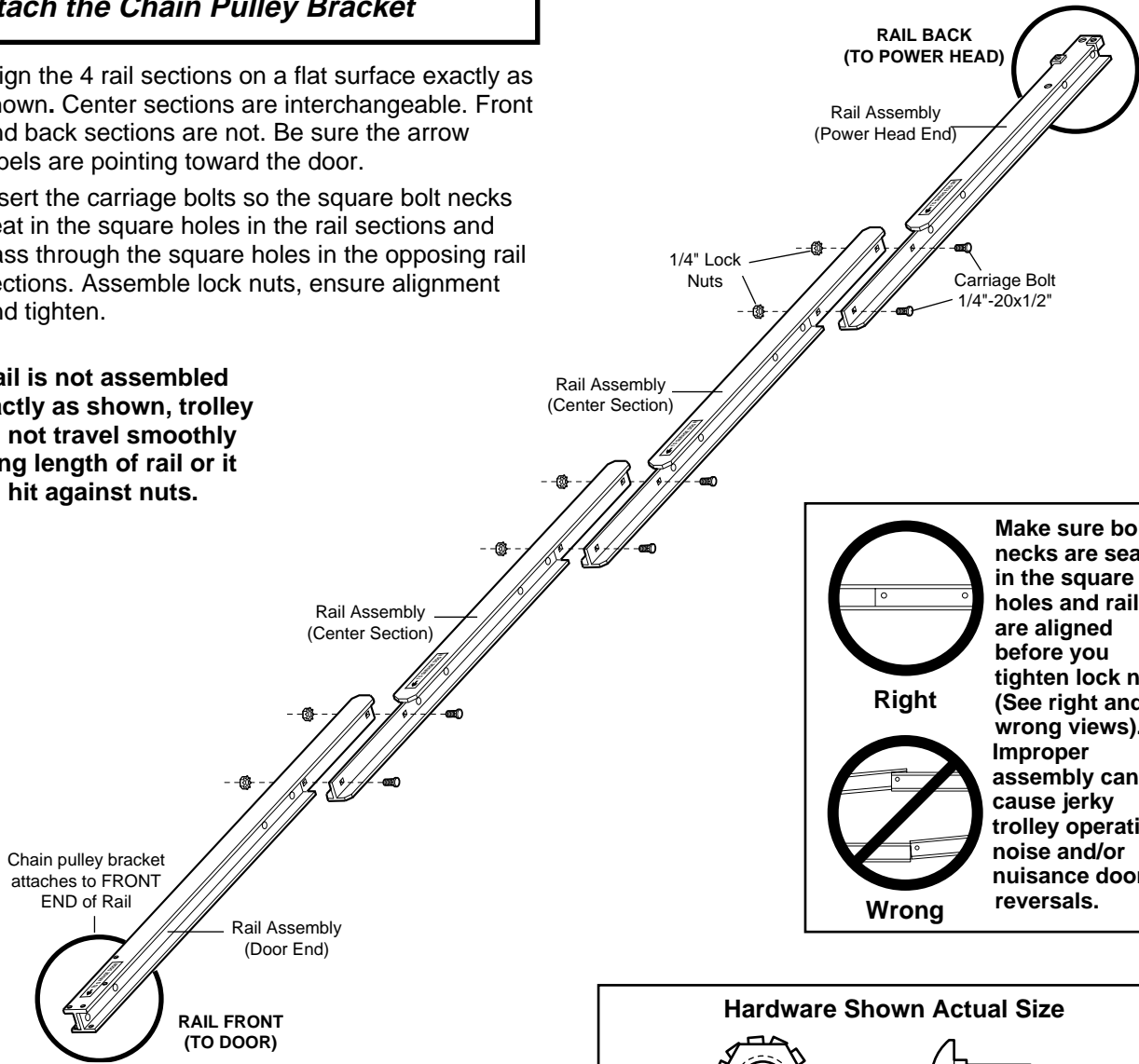

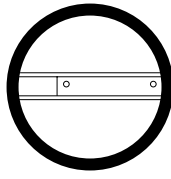

Right

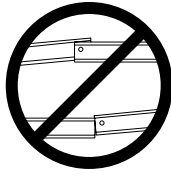

Wrong

Make sure bolt necks are seated in the square holes and rails are aligned before you tighten lock nuts. (See right and wrong views). Improper assembly can cause jerky trolley operation, noise and/or nuisance door reversals.

- Position the chain pulley bracket on the front end of the rail as shown. Fasten securely with the hardware shown.

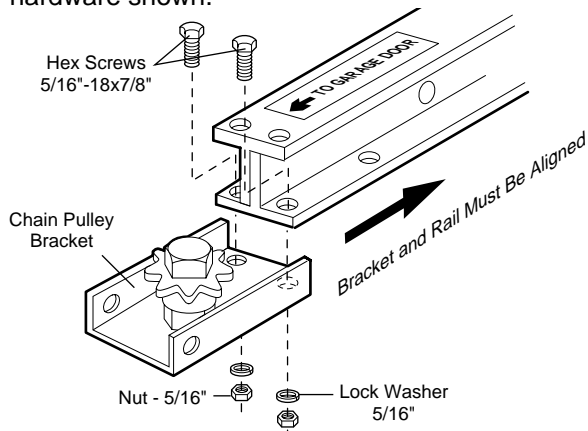

Hardware Shown Actual Size

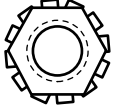

Lock Nut
1/4"-20x7/16"

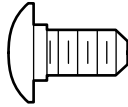

Carriage Bolt
1/4"-20x1/2"

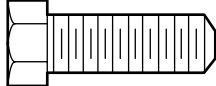

Hex Screw
5/16"-18x7/8"



Nut
5/16"-18



Lock Washer
5/16"

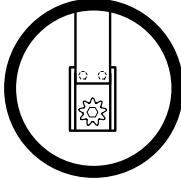

Right

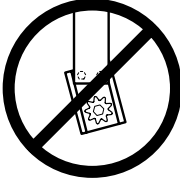

Wrong

When tightening the screws, be sure to keep bracket parallel to the rail. Otherwise, the rail may bow when the opener is operated.

Assembly Step 2

Install the Trolley on the Rail

- Attach the threaded shaft to the trolley with the lock washer and nuts as shown.

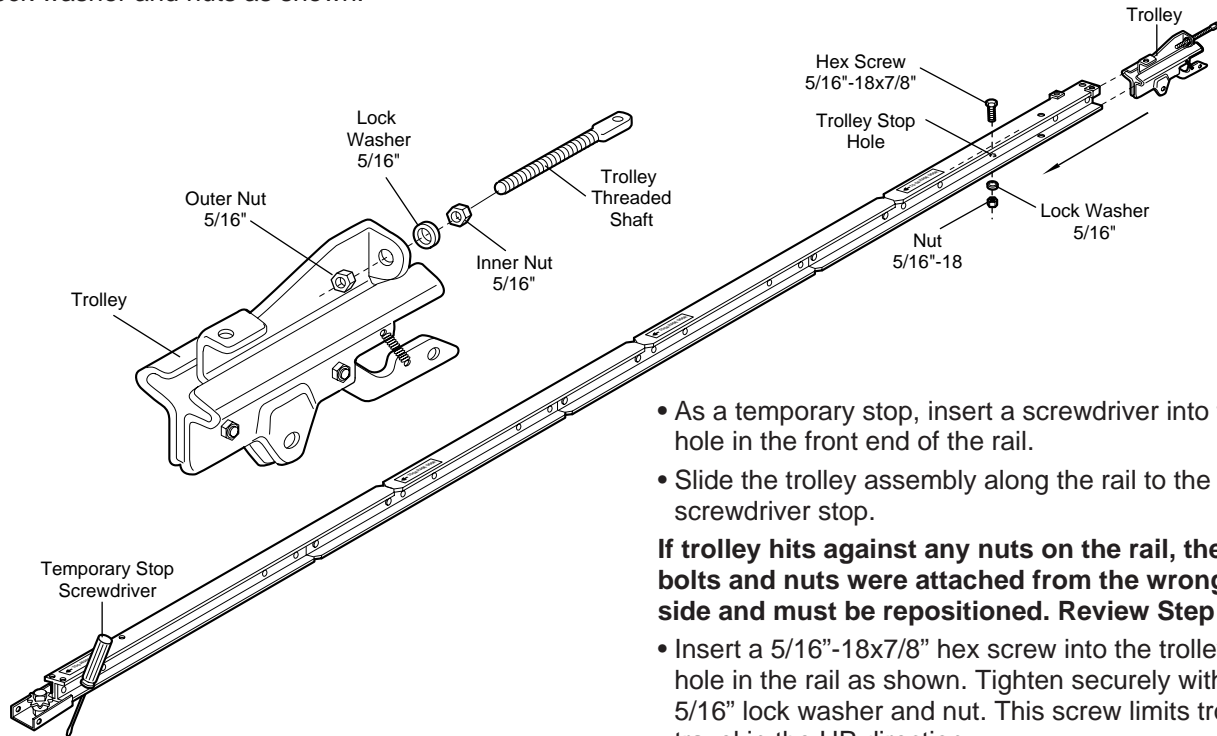

Hardware Shown Actual Size

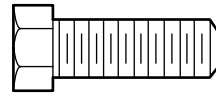

Hex Screw
5/16"-18x7/8"

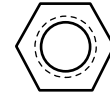

Nut
5/16"

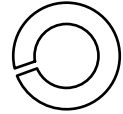

Lock Washer
5/16"-18

- As a temporary stop, insert a screwdriver into the hole in the front end of the rail.
- Slide the trolley assembly along the rail to the screwdriver stop.

If trolley hits against any nuts on the rail, the bolts and nuts were attached from the wrong side and must be repositioned. Review Step 1.

- Insert a 5/16"-18x7/8" hex screw into the trolley stop hole in the rail as shown. Tighten securely with a 5/16" lock washer and nut. This screw limits trolley travel in the UP direction.

Assembly Step 3

Fasten the Rail to the Power Head

- Place the power head on packing material to protect the cover. For convenience, put a support under the chain pulley bracket.
- Remove the (2) 5/16"-18x1/2" washered screws mounted in the top of the power head.
- Align the holes in the back section of the rail with the holes in the power head, as shown.
- Fasten the rail with the (2) washered screws previously removed. Tighten securely.

Remember to use only these screws! Any other screws will cause serious damage to the power head.



CAUTION

To fasten rail, use only those screws mounted in the top of the power head. Any other screws will cause serious damage to the power head.

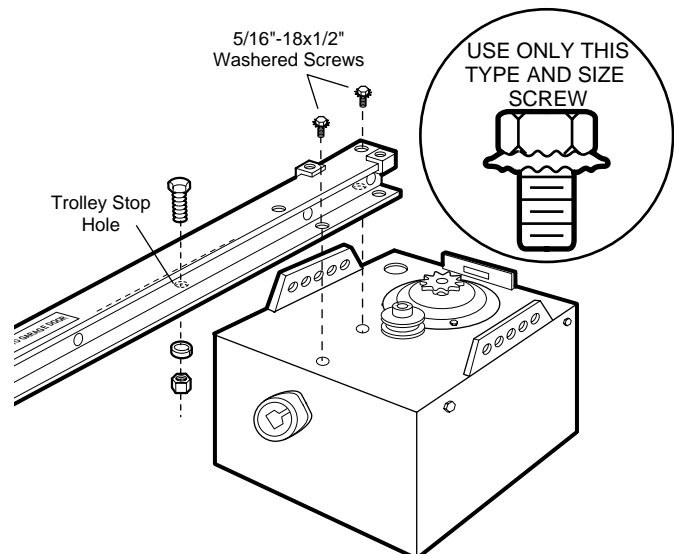

Assembly Step 4

Attach the Chain & Rail Support Bracket

- Remove the chain end from the carton and fasten it to the trolley with a master link from the hardware bag. See master link procedure, Figure 1.
- With the trolley against the screwdriver, dispense the chain around the pulley.
- Proceed back around the rail to the power head, Figure 2. Guide the chain around the chain spreader and sprocket. Be sure sprocket teeth engage the chain.
- Continue forward to the trolley threaded shaft, Figure 3.
- Use the second master link to connect the chain to the flat end of the shaft. If necessary, loosen the outer nut on the trolley to obtain more chain slack. **Check to make sure the chain is not twisted.**
- Remove the screwdriver.

Figure 1

Master Link Procedure:

Push pins of master link bar through chain end and hole in front end of trolley. Push cap over pins and past notches. Slide clip-on spring over cap and into notches until both pins are securely locked.

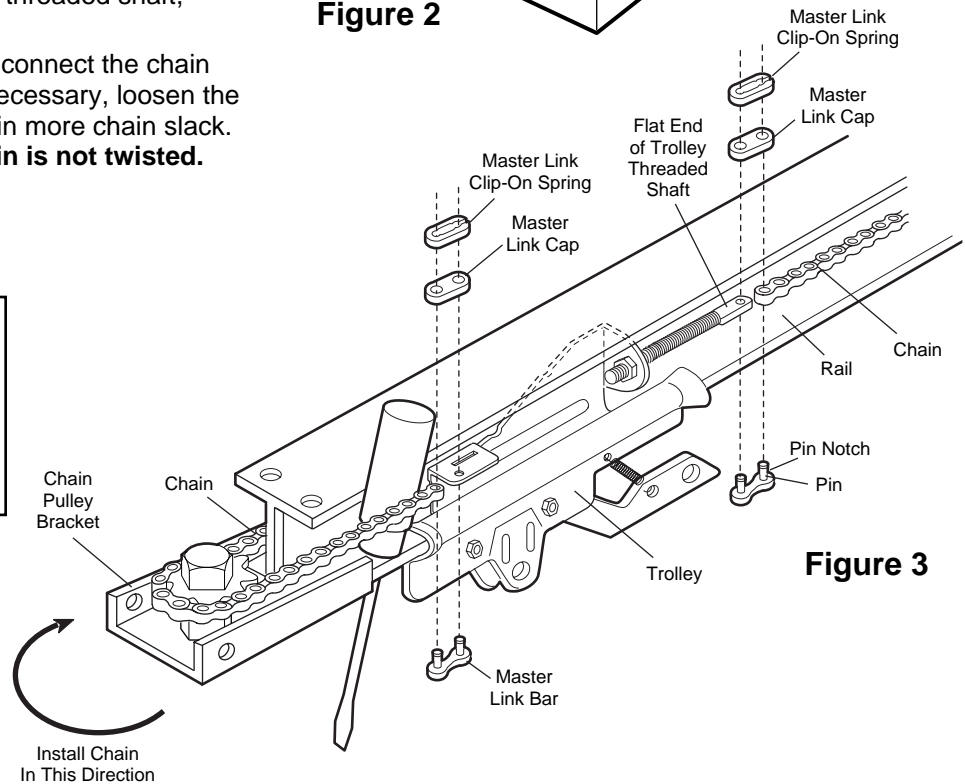
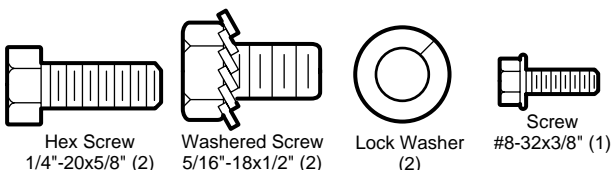

Figure 3

To attach the rail support bracket:

- Position the rail support bracket on the power head.
- Attach the bracket to the rail with 1/4"20x5/8" hex screws and lock washers.
- Attach the bracket to the power head by inserting a 5/16"-18x1/2" washered screw through a hole in each side flange and a matching hole in the bracket. Complete the connection by inserting the #8-32x3/8" screw through the back flange and the hole in the rail support.

Hardware Shown Actual Size



WARNING

Serious injury can result if fingers become entangled in moving opener sprocket. Attach sprocket cover securely. Never operate opener while your hand is near the opener sprocket.

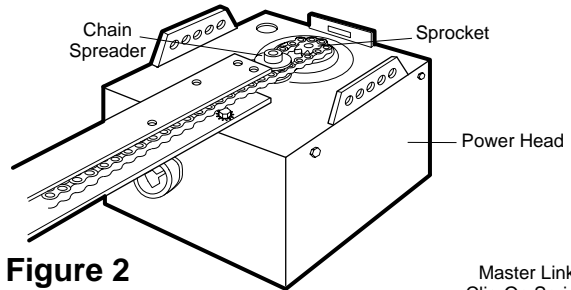
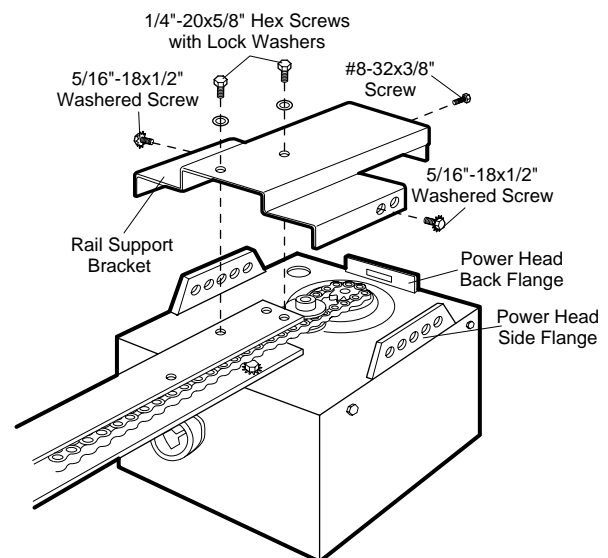
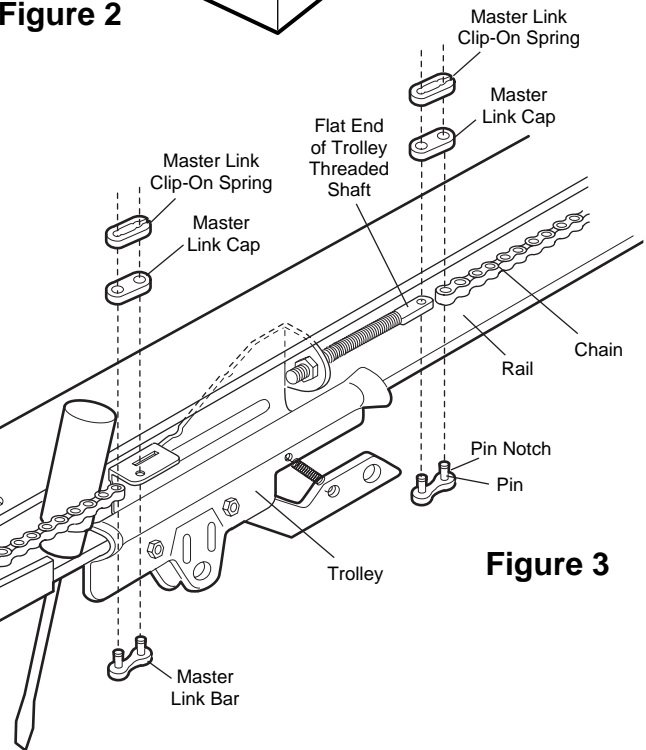

Figure 2



Assembly Step 5

Tighten the Chain

- Spin the inner nut and lock washer down the threaded shaft, away from the trolley.
- To tighten the chain, turn outer nut in the direction shown. **As you turn the nut, keep the chain from twisting.**
- When the chain is approximately 1/2" above the base of the rail at its midpoint, re-tighten the inner nut to secure the adjustment.

Sprocket noise can result if chain is either too loose or too tight.

When installation is complete, you may notice some chain droop with the door closed. This is normal. If the chain returns to the position shown when the door is open, *do not re-adjust the chain.*

NOTE: During future maintenance, ALWAYS pull the manual release handle to disconnect trolley before adjusting chain.

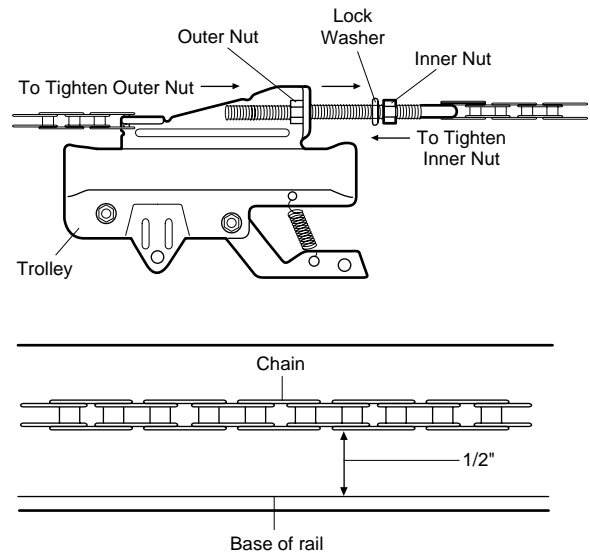

You have now finished assembling your garage door opener. Please read the following warnings before proceeding to the installation section:

IMPORTANT INSTALLATION INSTRUCTIONS



WARNING



WARNING

To reduce the risk of severe injury or death to persons:

1. **READ AND FOLLOW ALL INSTALLATION INSTRUCTIONS**
2. Install only on a properly balanced garage door. *An improperly balanced door may not reverse and could result in severe injury or death.* Repairs to cables, spring assemblies and other hardware must be made by a qualified service person before installing opener.
3. Disable all locks and remove all ropes connected to the garage door before installing the opener. *Ropes connected to a garage door can cause entanglement and death.*
4. If possible, install door opener 7 feet or more above floor with the manual release handle mounted 6 feet above the floor.
5. Do not connect the opener to power source until instructed to do so.
6. Locate the Door Control within sight of the door at a minimum height of 5 feet where small children cannot reach and away from all moving parts of the door.
7. Install the User Safety Instruction Label on the wall adjacent to the control button and the Maintenance Instruction Label in a prominent location on the inside of the garage door.
8. Upon completion of the installation, the door must reverse when it comes in contact with a one-inch high object (or a 2x4 laid flat) on the floor.
9. Do not wear watches, rings or loose clothing while installing or servicing an opener. Jewelry or loose clothing can be caught in the mechanism of the garage door or the opener.

Installation Step 1

Determine Header Bracket Location

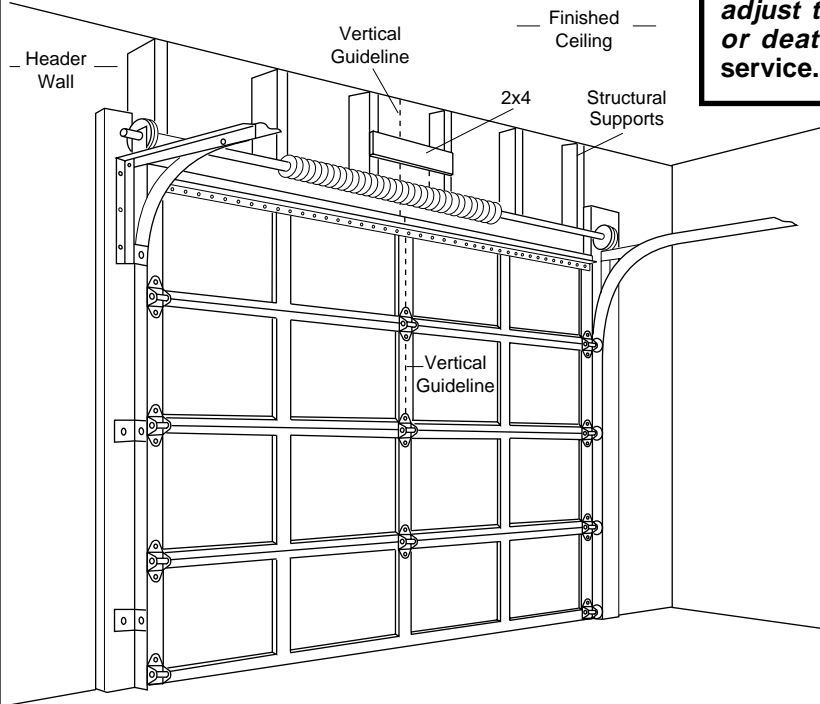

WARNING

If the header bracket is not rigidly fastened to a structural support on the header wall or ceiling, the safety reverse system may not work properly (see page 26). *The door might not reverse when required, and could cause serious injury or death.*

The garage door springs, cables, pulleys, brackets and their hardware are under extreme tension. *Do not attempt to loosen, move or adjust them yourself. Serious personal injury or death could result. Call for garage door service.*

- Close the door and mark the inside vertical centerline of the garage door.
- Extend the line onto the header wall above the door.

Remember, you can fasten the header bracket within 2 feet to the left or right of the door center *only* if a torsion spring or center bearing plate is in the way; or you can attach it to the ceiling (refer to page 12) when clearance is minimal. (It may be mounted on the wall upside down if necessary, to gain approximately 1/2".)

If you need to install the header bracket on a 2x4 (on wall or ceiling), use lag screws (not supplied) to securely fasten the 2x4 to structural supports as shown here.

- Open your door to the highest point of travel as shown. Draw an intersecting horizontal line on the header wall 2" above the high point. This height will provide travel clearance for the top edge of the door.

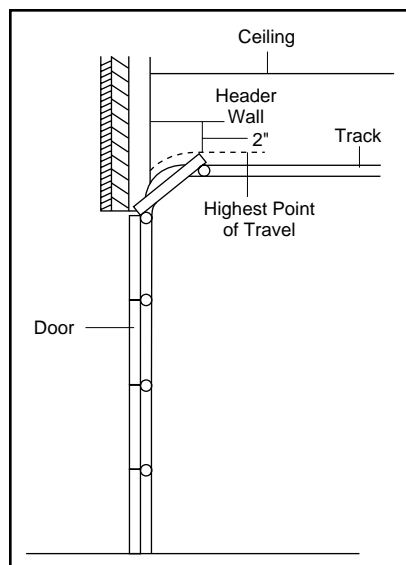

Proceed to Step 2, page 12.

Installation Step 2

Install the Header Bracket

You can attach the header bracket either to the wall above the garage door, or to the ceiling. Follow the instructions which will work best for your particular requirements.

Fasten the Header Bracket to the Wall

- Center the bracket on the vertical guideline with the bottom edge of the bracket on the horizontal line as shown (with the arrow pointing toward the ceiling).

- Mark either set of bracket holes (do not use the holes designated for ceiling mount). Drill 3/16" pilot holes and fasten the bracket securely to a structural support with the hardware provided.

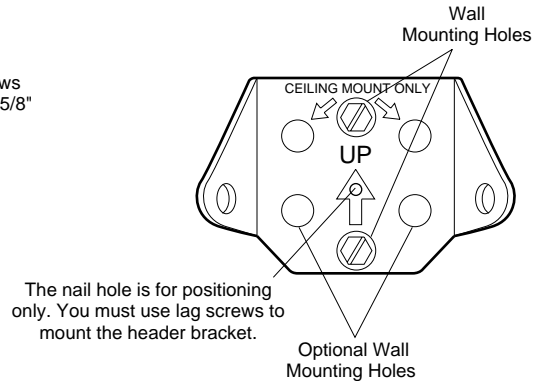
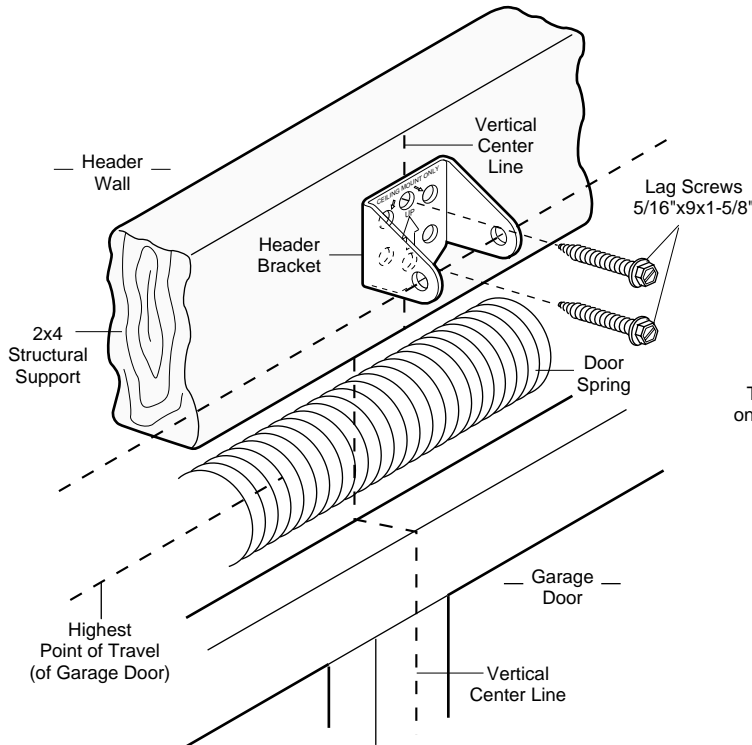

Hardware Shown Actual Size

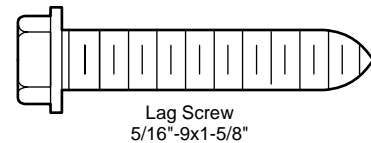

Fasten the Header Bracket to the Ceiling

- Extend the vertical guideline onto the ceiling as shown.
- Center the bracket on the vertical mark, no more than 6" from the wall. Make sure the arrow is pointing toward the wall. The bracket can be mounted flush against the ceiling when clearance is minimal.
- Mark holes designated for ceiling mount only. Drill 3/16" pilot holes and fasten the bracket securely to a structural support with the hardware provided.

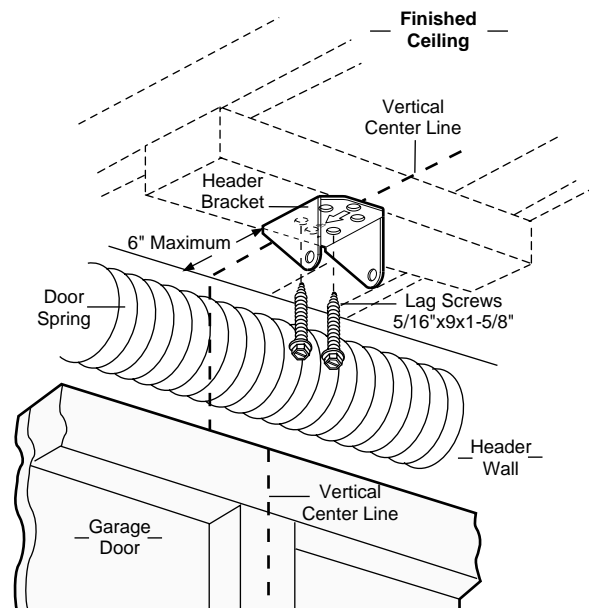
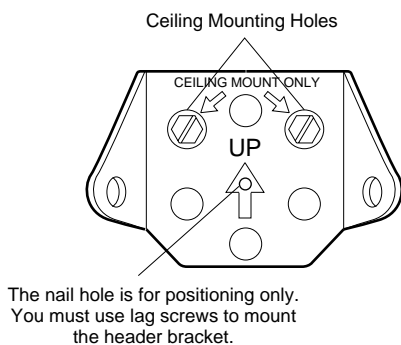

Installation Step 3

Attach the Rail to the Header Bracket

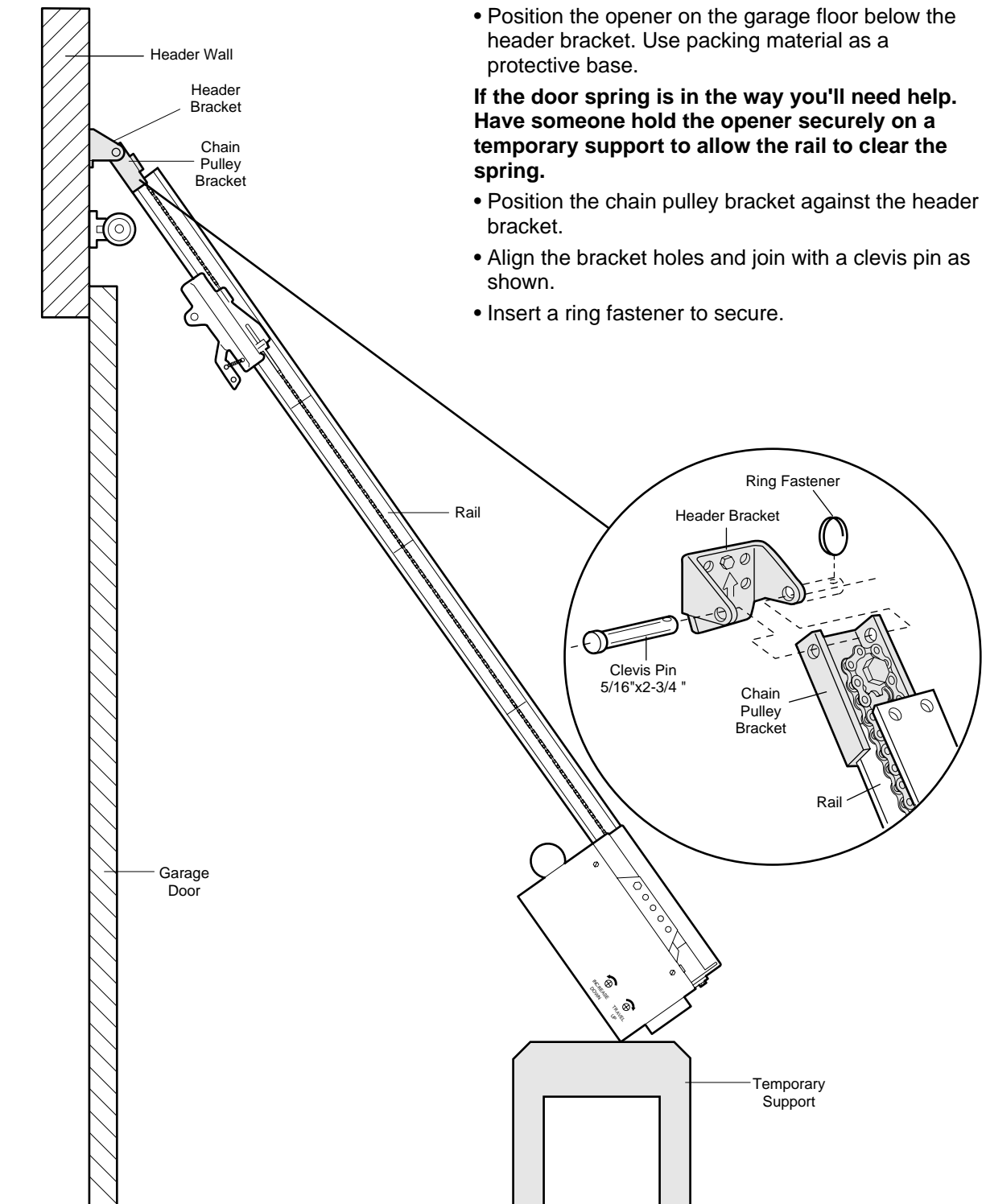

Hardware Shown Actual Size

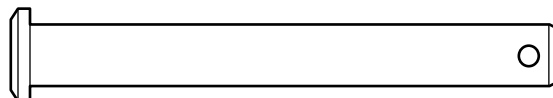

Clevis Pin
5/16" x 2-3/4"



Ring Fastener

Installation Step 4

Position the Opener



CAUTION

To prevent damage to steel, aluminum, fiberglass or glass panel doors, do not rest the opener on the door without using a 2x4.

A 2x4 laid flat is convenient for setting an ideal door-to-rail distance.

- Raise the opener onto a stepladder.

You will need help at this point if the ladder is not tall enough.

- Open the door all the way and place a 2x4 laid flat on the top section beneath the rail.

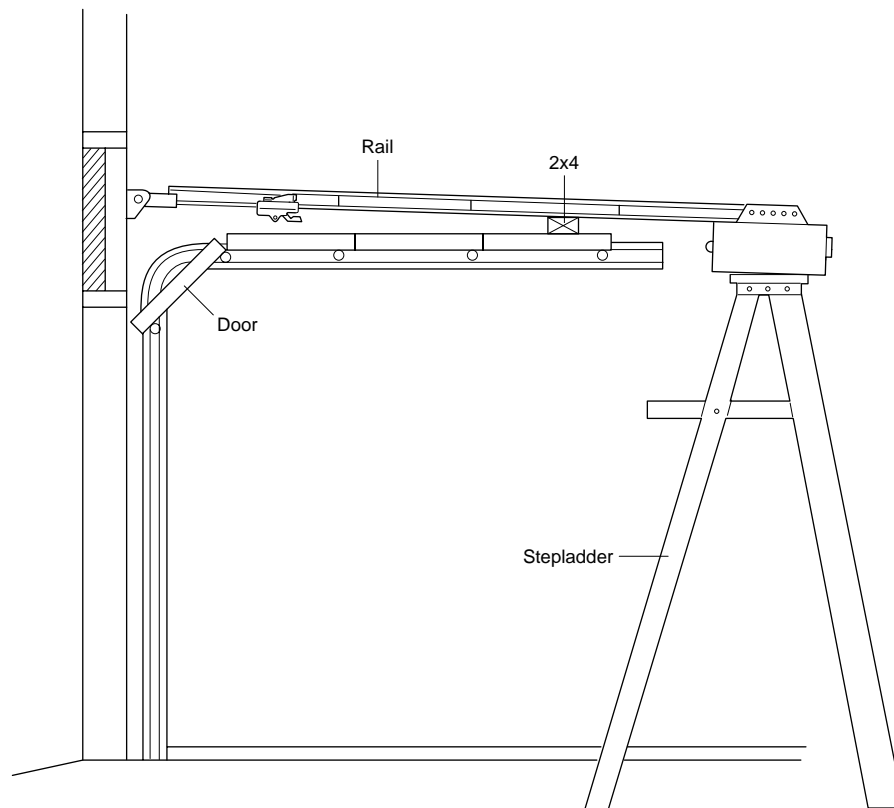

- *If the top panel hits the trolley when you raise the door, pull down on the trolley release arm to disconnect the inner and outer sections. The trolley can remain disconnected until Step 12 is completed.*

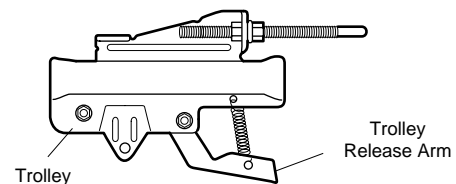

Installation Step 5

Hang the Opener

Two representative installations are shown. Yours may be different. Hanging brackets should be angled, Figure 1, to provide rigid support. On finished ceilings, Figure 2, attach a sturdy metal bracket to structural supports in ceiling before installing the opener. The bracket and fastening hardware are not supplied.

- Measure the distance from *each* side of the opener to the structural support.
- Cut both pieces of the hanging bracket to required lengths.
- Drill 3/16" pilot holes in the structural supports.
- Attach one end of each bracket to a support with 5/16"x1-5/8" lag screws.
- Fasten the opener to the hanging brackets with 5/16"-18x7/8" hex screws, lock washers and nuts.
- Check to make sure the rail is centered over the door (or in line with the header bracket if the bracket is not centered above the door).
- Remove the 2x4. Operate the door manually. If the door hits the rail, raise the header bracket.



Grease the top and underside of the rail surface where the trolley slides. A tube of grease is supplied.

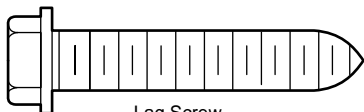

Lag Screw
5/16"-9x1-5/8"

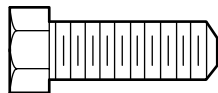

Hex Screw
5/16"-18x7/8"



Nut
5/16"-18



Lock Washer 5/16"



WARNING

The opener could fall and injure someone if it is not properly secured. Fasten the opener securely to structural supports of the garage.

Figure 1

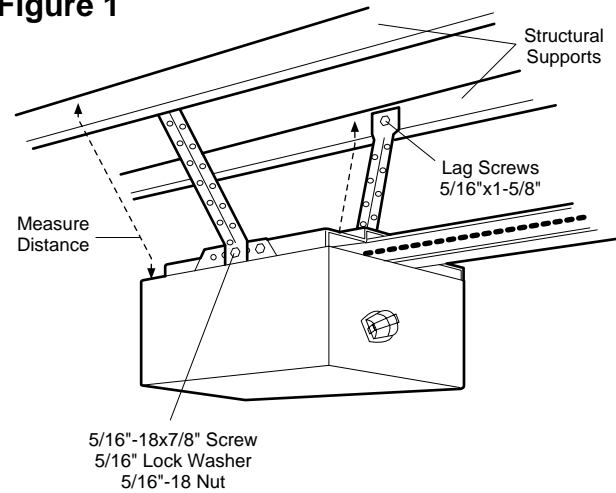
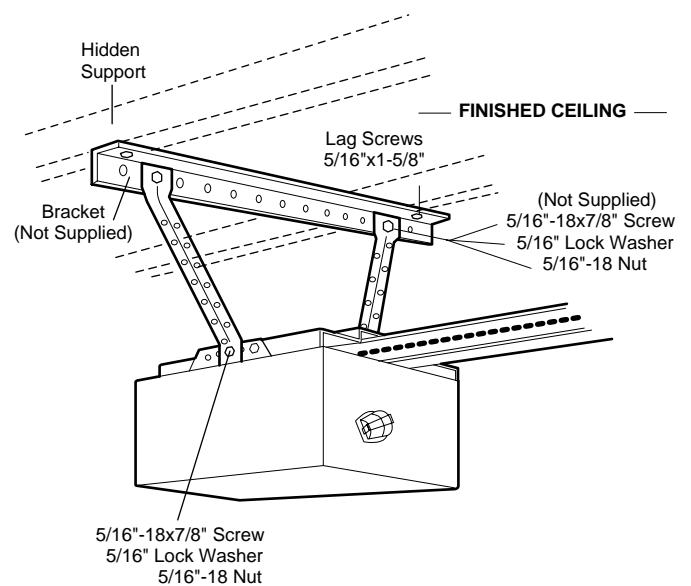

Figure 2



Installation Step 6

Install the Door Control

- Strip 1/4" of insulation from one end of the bell wire; connect the wire to the two screw terminals on the back of the Door Control: white to 2, and white/red to 1.
- Locate the Door Control within sight of the door at a minimum height of 5 feet where small children cannot reach, and away from all moving parts of the door and door hardware.** Fasten the Door Control securely with 6ABx1-1/2" screws. If installing into drywall, drill 5/32" holes and use the anchors provided.
- Run the bell wire up the wall and across the ceiling to the opener. Use insulated staples to secure the wire in several places. Be careful not to pierce the wire with a staple, thereby resulting in a short.
- Receiver terminal screws and the antenna are located on the back panel of the opener. Position the antenna wire as shown.
- Then connect the bell wire to the opener terminal screws: white to 2 and white/red to 1.
- Remember to affix the User Safety Instruction label to the wall near the Door Control, and the Maintenance Instruction Label in a prominent location on the inside of the garage door.**

If the label adhesive will not adhere to your garage wall surface (or becomes loose with time), use tacks to secure the label alongside the Door Control. Page 29 explains how to operate the opener using the door control.

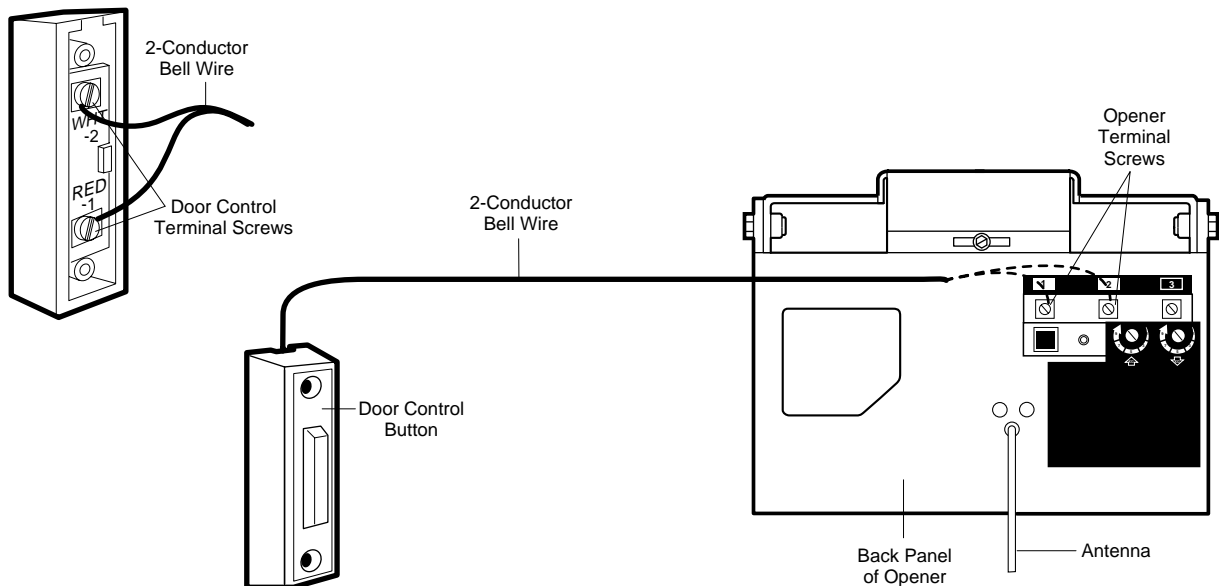

WARNING

Children operating or playing with a garage door opener can injure themselves or others. **The garage door could close and cause serious injury or death.**

Install the Door Control (or any additional push buttons) out of the reach of children and away from all moving parts of the door and door hardware, **but where the garage door is visible.** Do not allow children to operate the push buttons or the remote control transmitters.

A moving garage door could injure someone under it. Activate the opener only when the door is properly adjusted, you can see it clearly, and there are no obstructions to door travel.

Do NOT connect the power and operate the opener at this time. The trolley will travel to the full open position but will not return to the close position until the sensor beam is connected and properly aligned.

See Safety Reversing Sensor Instructions

Hardware Shown Actual Size

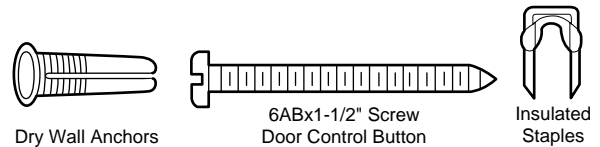

Installation Step 7

Install the Light

Install the Light

- Install a 75 watt maximum light bulb in the socket. The light will turn ON and remain lit for approximately 4-1/2 minutes when power is connected. Then the light will turn OFF.
- If the bulb burns out prematurely due to vibration, replace with a *standard neck* "Garage Door Opener" bulb.

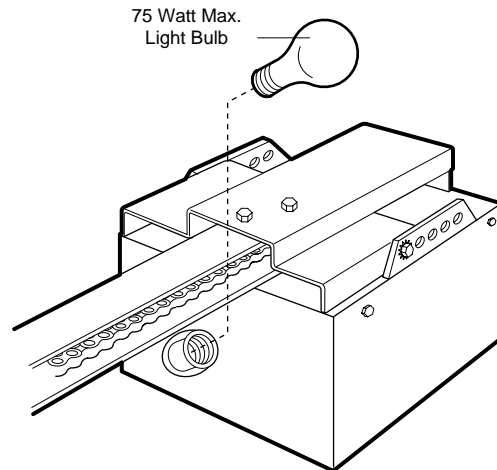

Installation Step 8

Attach the Manual Release Rope and Handle

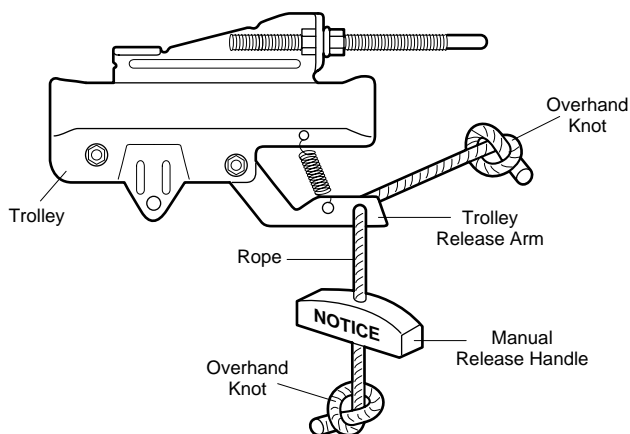

WARNING

Do not use the red handle to pull the door open or closed. *The rope knot could become untied and you could fall.* Use the manual release only to disengage the trolley and, if possible, only when the door is closed.

Garage doors are heavy. If the door is open when the handle is pulled, the door could close inadvertently if it is not properly balanced. Serious injury may result to persons under the door. Make sure the doorway is clear of persons and obstructions before pulling handle when door is open.

- Thread one end of the rope through the hole in the top of the red handle so "NOTICE" reads right side up as shown. Secure with an overhand knot.
- Thread the other end of the rope through the hole in the release arm of the outer trolley.
- Adjust rope length so the handle is 6 feet above the floor. Secure with an overhand knot.

If it is necessary to cut the rope, heat seal the cut end with a match or lighter to prevent unraveling.

Installation Step 9

Electrical Requirements

To reduce the risk of electric shock, your garage door opener has a grounding type plug with a third grounding pin. This plug will *only* fit into a grounding type outlet.

If the plug doesn't fit into the outlet you have, contact a qualified electrician to install the proper type outlet.

To avoid installation difficulties, do not run the opener at this time.



WARNING

To prevent electrocution or fire, installation and wiring must be in compliance with local electrical and building codes.

Do **NOT** use an extension cord, 2-wire adapter, or change the plug in any way to make it fit your outlet.

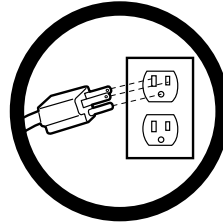

Right

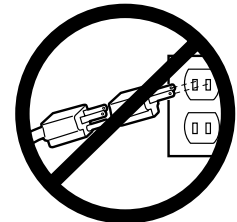

Wrong

If permanent wiring is required by your local code, refer to the following procedure:



WARNING

To prevent electrocution, remove power from the garage door opener *and* from the circuit you plan to use for the permanent connection.

To make a permanent connection through the 7/8" diameter hole in the top of the opener (according to local code):

- Remove the opener cover screws and set the cover aside.
- Remove the attached 3-prong cord.
- Connect the black (line) wire to the screw on the brass terminal; the white (neutral) wire to the screw on the silver terminal; and the ground wire to the green ground screw. **The opener must be grounded.**
- Reinstall the cover.

To avoid installation difficulties, do not run the opener at this time.

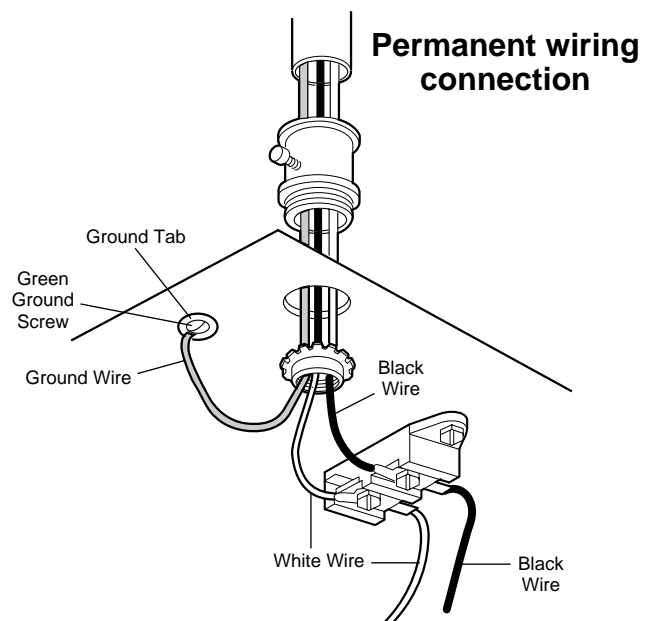

The Protector System®

Information you'll need before you begin the installation of the safety reversing sensor.

The safety reversing sensor *must* be connected and aligned correctly before the garage door opener will move in the down direction. This is a required safety device and cannot be disabled.

Be sure power to the opener is disconnected.

The sending eye transmits an invisible light beam to the receiving eye. The units can be installed on either side of the garage door as long as the sun never shines directly into the receiving eye lens.

Look at the label on the connector end of each case to identify the sensors.

The brackets must be connected and fastened so that the sending and receiving eyes face each other as shown below in Figure 1.

If an obstruction breaks the light beam while the garage door is closing, the door will stop and reverse to full open position and the opener lights will flash for 5 seconds.

The brackets *must* be securely fastened to a solid surface such as the studs on either side of the door, or add a piece of wood at each location if installing in masonry construction.

**WARNING**

Without a properly working safety reversing sensor, persons (particularly children) could be killed by a closing garage door. Read and follow all instructions.

To protect small children, install the safety reversing sensor so that the beam will be no higher than 4-6" above the garage floor.

Disconnect power to the garage door opener before installing the safety reversing sensor.

The invisible light beam path must be unobstructed. No part of the garage door (or door tracks, springs, hinges, rollers or other hardware) can interrupt the beam while the door is closing. If it does, use a piece of wood to build out each sensor mounting location to the minimum depth required for light beam clearance.

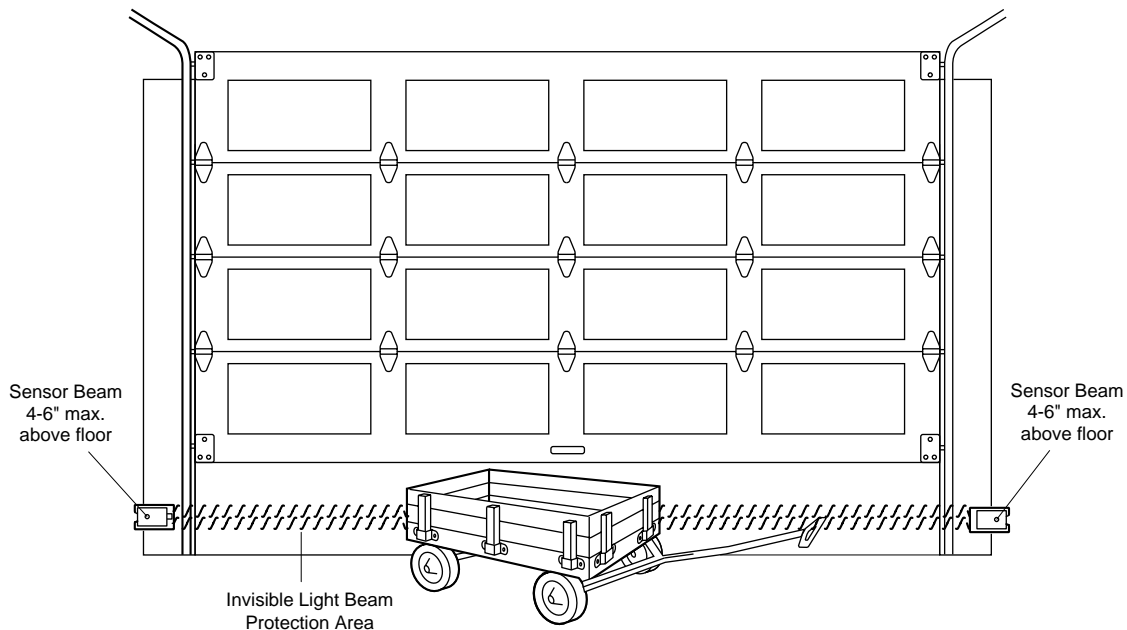

Figure 1: Facing the door from inside the garage

Installation Step 10

Install the Safety Reversing Sensor (Receiving and Sending Eyes)

Figures 2, 3 and 4 show recommended assembly of bracket(s) and "C" wrap based on the wall installation of the sensors on each side of the garage door as shown on page 19, or on the garage door tracks themselves.

For Garage Wall or Door Track Installation

- Fasten the "C" wraps to the mounting brackets having square holes, using the hardware shown in Figure 2.

For Door Track Installation Only

- Discard slotted bracket. Drill 3/8" holes in each track and fasten securely with hardware as shown in Figure 3.

For Wall Installation

- Connect each assembly to a slotted bracket, using the hardware shown in Figure 4. **Note alignment of brackets for left and right sides of the door.**
- Finger tighten the lock nuts.
- Use bracket mounting holes as a template to locate and drill (2) 3/16" diameter pilot holes on both sides of the garage door, 4"-6" above the floor *but not exceeding 6"*. (See warning on page 19.)
- Attach bracket assemblies with 1/4"x1-1/2" lag screws as shown in Figure 4.
- Adjust right and left side bracket assemblies to the same distance out from mounting surface. Make sure all door hardware obstructions are cleared. Tighten the nuts securely.

Figure 2

Garage WALL or DOOR TRACK Installation

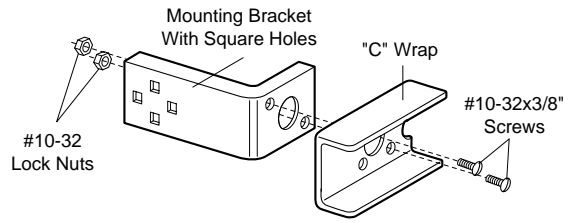

Figure 3

Garage DOOR Track Installation

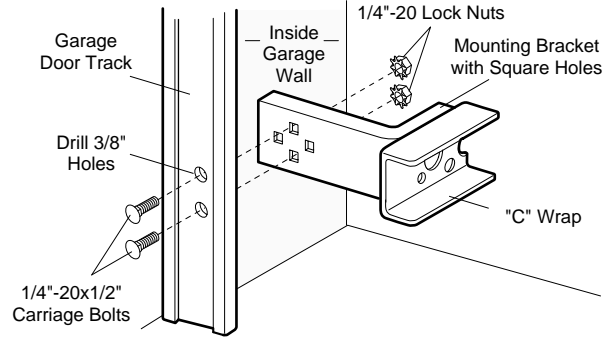
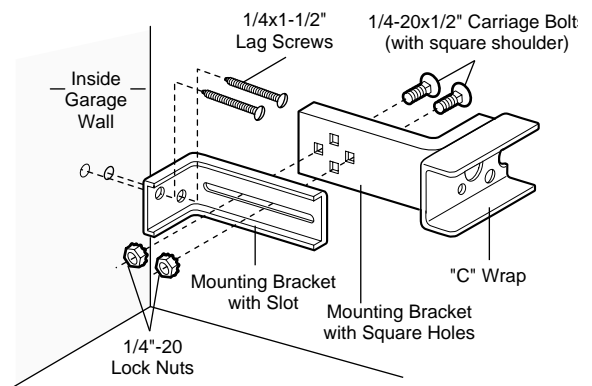

Figure 4

Garage WALL Installation



Figures 5 and 6 are variations which may fit your installation requirements better. **Make sure the wraps and brackets are aligned so the sensors will face each other across the garage door.**

Figure 5

Alternate Wall Mount

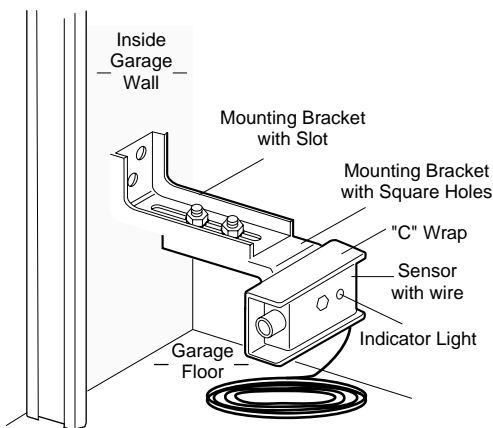
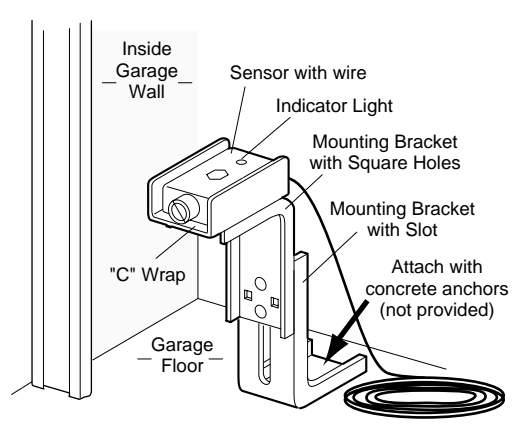

Figure 6

Alternate Floor Mount



Hardware Shown Actual Size



Screw #10-32x3/8"



Lock Nut #10x32



Lag Screw 1/4"-1-1/2"

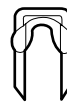

Insulated Staples

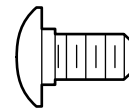

Carriage Bolt 1/4"-20x1/2"

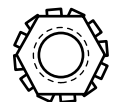

Lock Nut 1/4"-20

- Center each sensor unit in a "C" wrap with lenses pointing toward each other across the door (see Figure 7).
- Secure sensors with the hardware shown. Finger tighten the wing nut on the *receiving eye* to allow for final adjustment. Securely tighten the *sending eye* wing nut.
- Run the wires from both sensors to the opener. Use insulated staples to secure wire to wall and ceiling.
- Strip 1/4" of insulation from each set of wires. Separate white and white/black wires sufficiently to connect to the opener terminal screws: white to 2 and white/black to 3.
- Plug in the opener. Green indicator lights in both the sending and receiving eyes will *glow steadily* if wiring connections and alignment are correct.

If the indicator light is *off* in the *receiving eye* (and the invisible light beam path is not obstructed), alignment is required.

- Loosen the receiving eye wing nut to allow slight rotation of unit. Adjust sensor vertically and horizontally until the green indicator light *glows with a steady light*.
- When indicator lights are *glowing steadily* in both units, tighten the wing nut in the receiving eye unit.

Figure 7

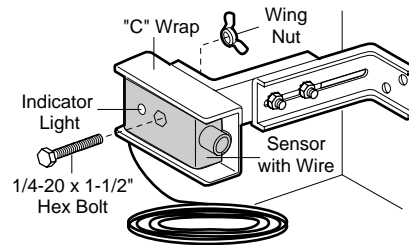

Trouble Shooting

1. If the *sending eye* indicator light does not *glow steadily* after installation, check for:
 - Electric power to the opener.
 - A short in the white or white/black wires. These can occur under staples or at screw terminal connections.
 - Incorrect wiring between sensors and opener.
 - An open wire (wire break).
2. If the sending eye indicator light *glows steadily* but the receiving eye indicator light doesn't:
 - Check alignment.
 - Check for an open wire to the receiving eye.

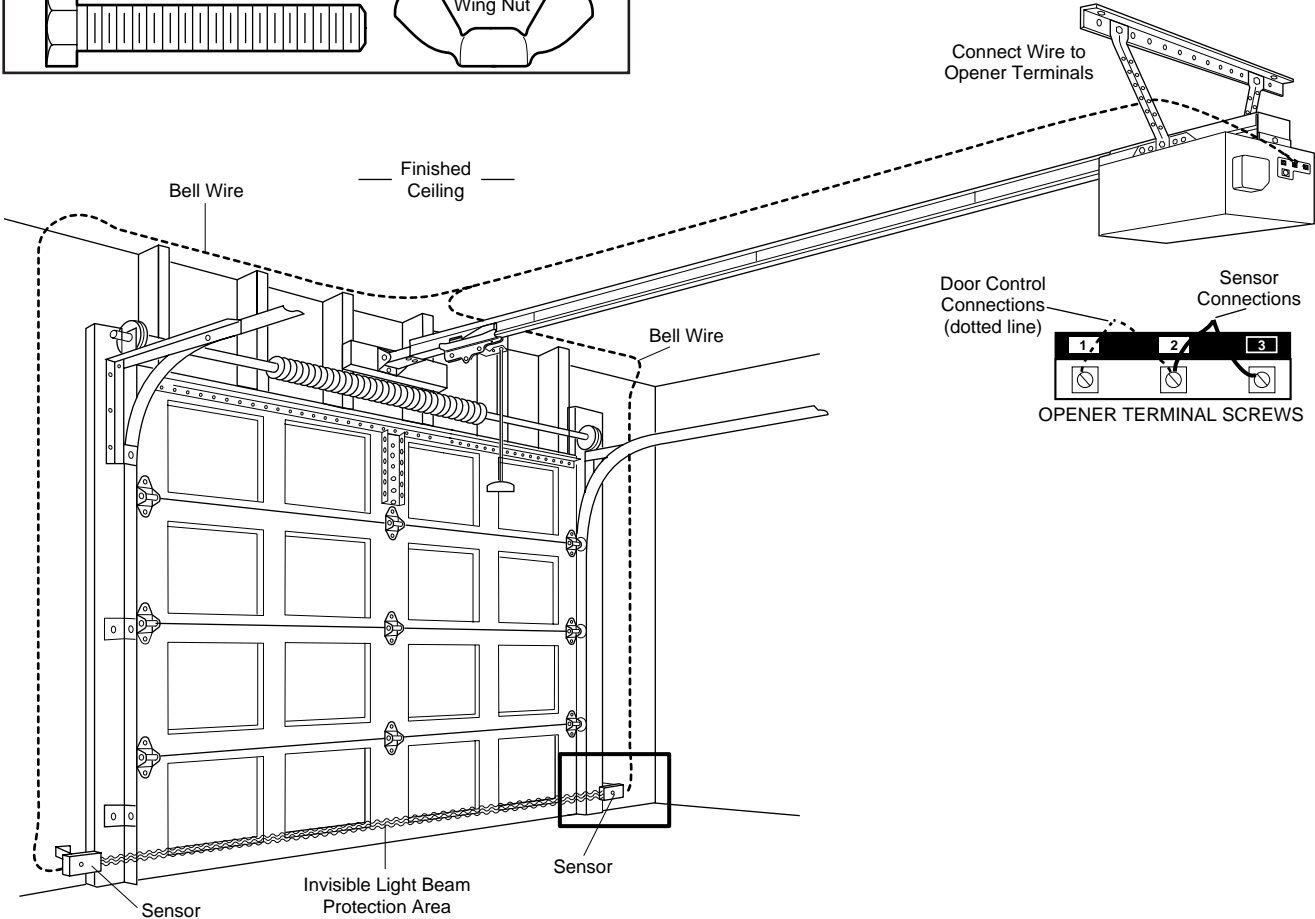
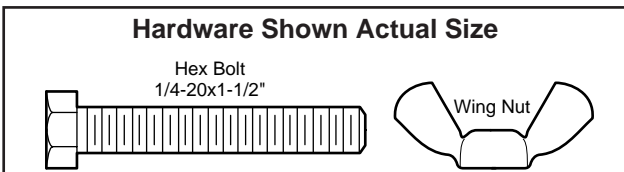

Installation Step 11

Fasten Door Bracket & Plate



CAUTION

To prevent damage to steel, aluminum, fiberglass or glass panel doors, always reinforce the inside of the door both vertically and horizontally with an angle iron.

A horizontal brace should be long enough to be secured to 2 vertical supports. A vertical brace should cover the height of the top panel.

The illustration shows one piece of angle iron as the horizontal brace. For the vertical brace, 2 pieces of angle iron are used to create a "U"-shaped support. The best solution is to check with your garage door opener installation, door reinforcement kit.

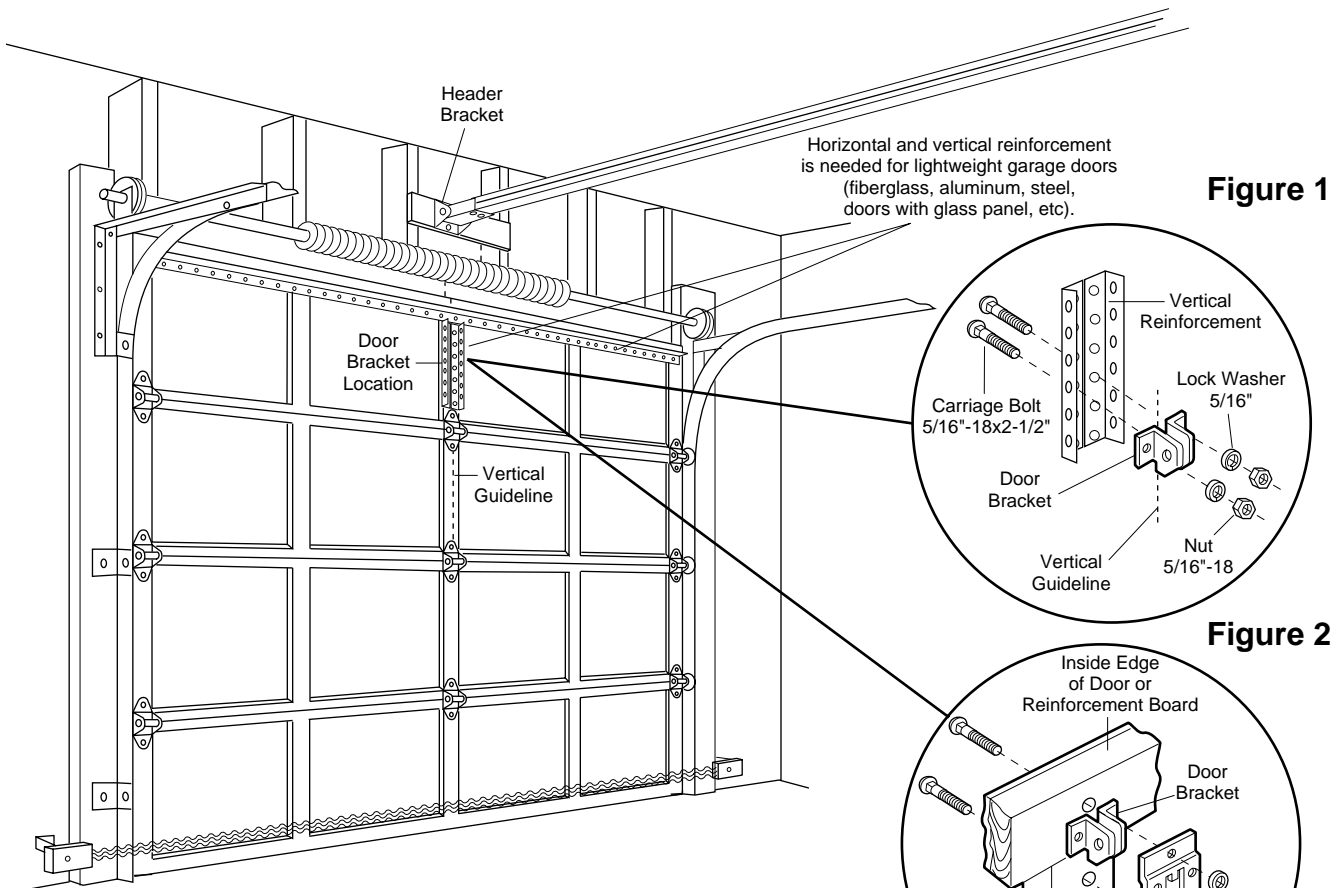

Figure 1

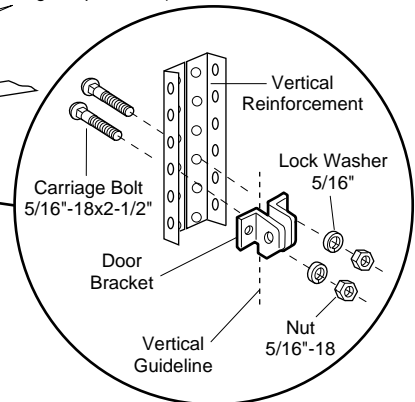
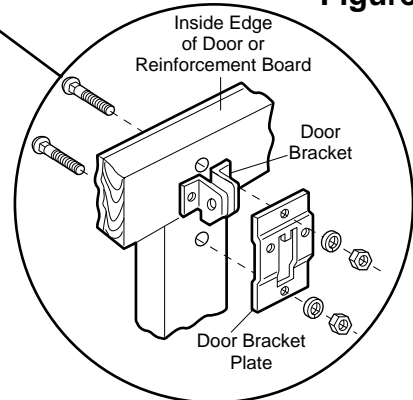

Figure 2



- Center the door bracket on the previously marked vertical guideline used for the header bracket installation.
- Position the bracket on the face of the door within the following limits:
 - A) The top edge of the bracket 2"-4" below the top edge of the door.
 - B) The top edge of the bracket directly below any structural support across the top of the door.
- Mark and drill 5/16" left and right fastening holes. Secure the bracket as shown in Figure 1 if there is vertical reinforcement.

If your installation doesn't require vertical reinforcement but does need top and bottom fastening holes for the door bracket, position the door plate over the door bracket as shown in Figure 2. Fasten securely with hardware shown in Figure 1.

Hardware Shown Actual Size



Nut
5/16"-18



Lock Washer
5/16"

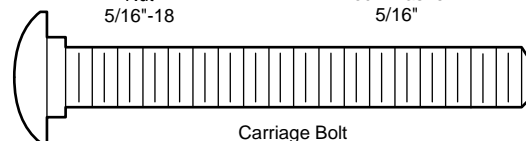

Carriage Bolt
5/16"-18x2-1/2"

Installation Step 12

Connect Door Arm to Trolley

Make sure garage door is fully closed. Pull the manual release handle to disconnect the outer trolley from the inner trolley. Slide the outer trolley back (away from the door) about 2" as shown in Figures 1, 2 and 3.

Figure 1:

- Fasten straight door arm section to outer trolley with a clevis pin. Secure the connection with a ring fastener.
- Fasten curved section to the door bracket in the same way as shown.

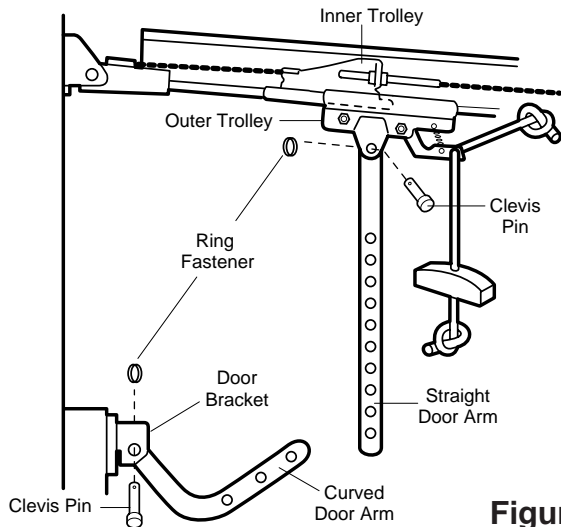

Figure 1

Figure 2:

- Bring arm sections together. Find two pairs of holes that line up and join sections. Select holes as far apart as possible to increase door arm rigidity.

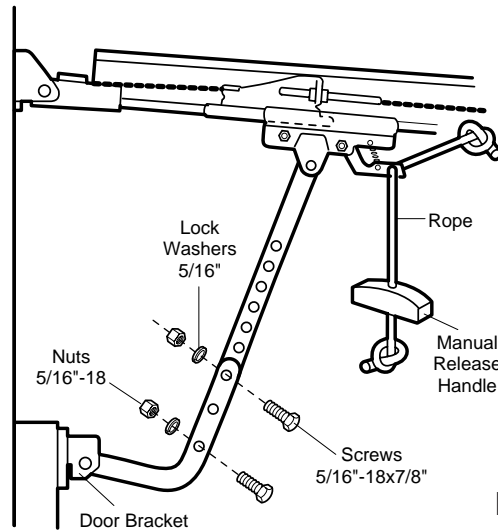

Figure 2

Hole Alignment Alternative

Figure 3:

- If holes in curved arm are *above* holes in straight arm, disconnect straight arm. Cut about 6" from the solid end. Reconnect to trolley with *cut end down* as shown.
- Bring arm sections together.
- Find two pairs of holes that line up and join with screws, lock washers and nuts.

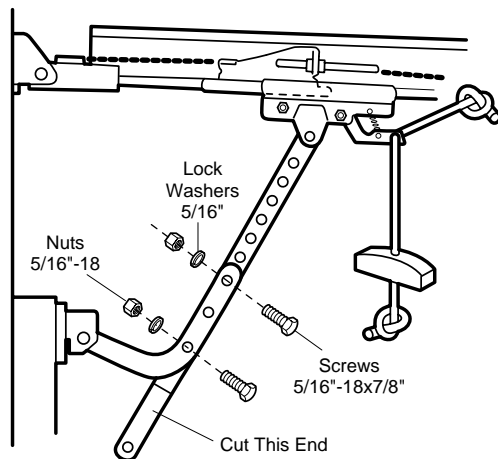
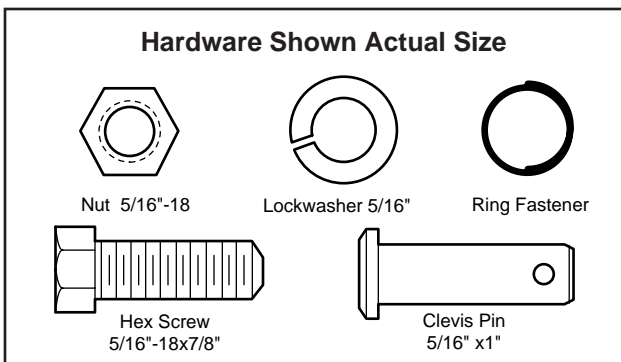

Figure 3

Proceed to Adjustment Step 1, page 24. Trolley will re-engage automatically when the opener is operated.

Adjustment Step 1

Adjust the UP and DOWN Limits

Do not make any limit adjustments until the Safety Reversing Sensors are completely installed.

Limit adjustment settings regulate the points at which the door will *stop* when moving up or down.

The door will *stop* in the *up* direction if anything interferes with door travel. The door will *reverse* in the *down* direction if anything interferes with the door travel (including binding or unbalanced doors).

To operate the opener, press the Door Control button. Run the opener through a complete travel cycle.

- Does the door open and close completely?
- Does the door stay closed and not reverse unintentionally when fully closed?

If your door passes both of these tests, no limit adjustments are necessary unless the reversing test fails (see page 26).

Adjustment procedures are outlined below. Run the opener through a complete travel cycle after each adjustment.

Repeated operation of the opener during adjustment procedures may cause the motor to overheat and shut off. Simply wait 15 minutes and try again.

Read the procedures carefully before proceeding to Adjustment Step 2. Use a screwdriver to make limit adjustments.



WARNING

Improper adjustment of the travel limits could interfere with the proper operation of the safety reverse system. See page 26. **The door might not reverse when required and could seriously injure or kill someone under it.**

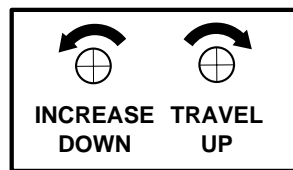
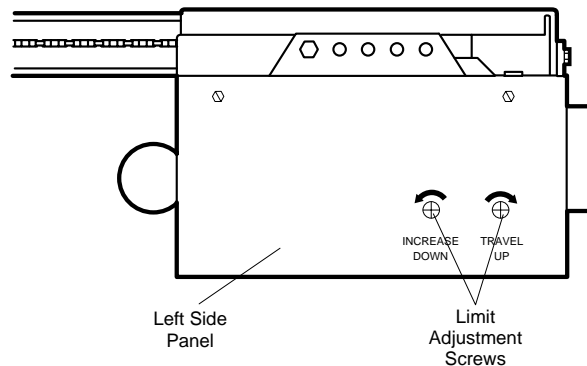

How and When to Adjust the Limits

If the door does not *open completely* but opens at least five feet:

Increase *up* travel. Turn the UP limit adjustment screw clockwise. One turn equals 2" of travel.

If door does not open at least 5 feet:

Adjust the UP (open) force as explained in Adjustment Step 2.

If the door does not *close completely*:

Increase *down* travel. Turn the DOWN limit adjustment screw counterclockwise. One turn equals 2" of travel.

If door still won't close completely, try lengthening the door arm. (See page 23.)

If you have adjusted the door arm to the maximum length and the door still will not close completely, lower the header bracket. See Installation Steps 1 and 2, pages 11 and 12.

If the opener *reverses* in fully closed position:

Decrease *down* travel. Turn the DOWN limit adjustment screw clockwise. One turn equals 2" of travel.

If the door *reverses* when closing and there is no visible interference to travel cycle:

If the opener lights are flashing, the Safety Reversing Sensor is obstructed. Remove the obstruction.

Test the door for binding: Pull the manual release handle. Manually open and close the door. If the door is binding, call for garage door service. If the door is not binding or unbalanced, adjust the DOWN (close) force. See Adjustment Step 2.

Adjustment Step 2

Adjust the Force

Force adjustment controls are located on the back panel of the opener. Force adjustment settings regulate the amount of power required to open and close the door.

The door will *stop* in the *up* direction if anything interferes with its travel. The door will *reverse* in the *down* direction if anything interferes with its travel (including binding or unbalanced doors).

If the forces are set too light, door travel may be interrupted by *nuisance reversals* in the *down* direction and *stops* in the *up* direction. Weather conditions can affect the door movement, so occasional adjustment may be needed.

The maximum force adjustment range is 260 degrees, about 3/4 of a complete turn. Do not force controls beyond that point. Turn force adjustment controls with a screwdriver.

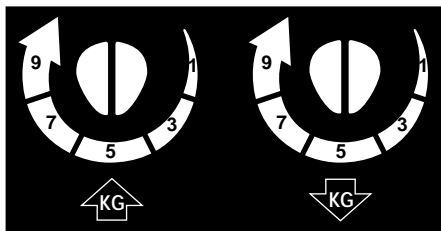

Adjustment Label

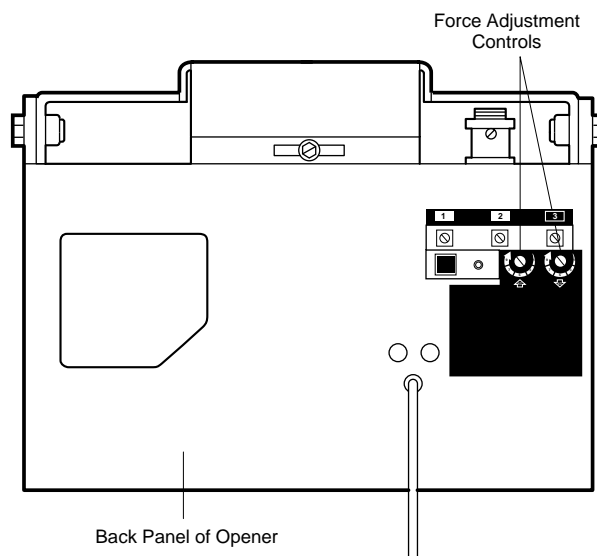

WARNING

Too much force on the door will interfere with the proper operation of the safety reverse system. ***The door might not reverse properly when required and could seriously injure or kill someone under it.*** Do not increase the force beyond the minimum required to close the door. Do not use the force adjustments to compensate for a binding or sticking garage door. Test the safety reverse system following all adjustments to force levels. See page 26.

How and When to Adjust the Forces

Test the DOWN (close) force:

Grasp the door bottom when the door is about halfway through DOWN (close) travel. The door should reverse. **(Reversal halfway through down travel does not guarantee reversal on a one inch obstruction. See page 26.)** If the door is hard to hold or doesn't reverse, decrease the DOWN (close) force by turning the control counterclockwise.

Make 10 degree turn adjustments until the door reverses normally. After each adjustment, run the opener through a complete cycle.

Test the UP (open) force:

Grasp the door bottom when the door is about halfway through UP (open) travel. The door should stop. If the door is hard to hold or doesn't stop, decrease UP (open) force by turning the control counterclockwise.

Make 10 degree turn adjustments until the door stops easily. After each adjustment, run the opener through a complete travel cycle.

If the door doesn't open *at least* 5 feet:

Increase UP (Open) force by turning the control clockwise. Make 10 degree turn adjustments until door opens completely. Re-adjust the UP limit if necessary. After each adjustment, run the opener through a complete travel cycle.

If the door *reverses* during the down (close) cycle and the opener lights aren't flashing:

Increase DOWN (close) force by turning the control clockwise. Make 10 degree turn adjustments until the door completes a close cycle. After each adjustment, run the opener through a complete travel cycle. **Do not increase the force beyond the minimum amount required to close the door.**

Adjustment Step 3

Test The Safety Reversing Sensor

- Press the Door Control button to open the door.
- Place the opener carton in the path of the door.
- Press the Door Control button to close the door.
The door will not move more than an inch, and the opener light will flash.

Professional service is required if the opener closes the door when the safety reversing sensor is obstructed.

The garage door opener will not close from a remote if the indicator light in either sensor is off, alerting you to the fact that the sensor is misaligned or obstructed.

The garage door can be closed by pressing and holding the Door Control button until down travel is completed.



WARNING

Without a properly working safety reversing sensor, persons (particularly children) could be seriously injured or killed if trapped by a closing garage door. Repeat this test once a month.

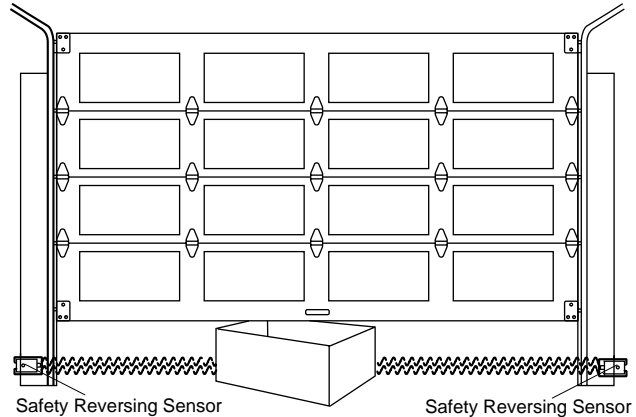

Adjustment Step 4

Test the Safety Reverse System

Test:

- Place a one-inch board (or a 2x4 laid flat) on the floor, centered under the garage door.
- Operate the door in the down direction. **The door must reverse on striking the obstruction.**

Adjustment:

If the door *stops* on the obstruction, it is not traveling far enough in the down direction.

- Increase the DOWN limit by turning the DOWN limit adjustment screw counterclockwise 1/4 turn.
- Repeat the test.

Make sure limit adjustments do not force the door arm beyond a straight up and down position. See the illustration on page 23.

- When the door reverses on the one-inch object (or 2x4 laid flat), remove the obstruction and run the opener through 3 or 4 complete travel cycles to test adjustment.

If the door will not reverse after repeated adjustment attempts, call for professional garage door service.



WARNING

Failure to test and adjust the safety reverse system may result in serious injury or death to persons trapped by a closing garage door. Repeat this test once a month and adjust as needed.

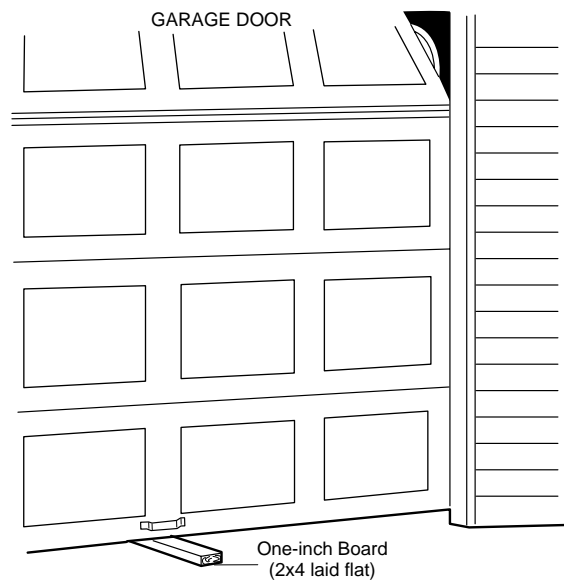

Important safety check

Repeat Adjustment Steps 1, 2 and 4 after:

- Each adjustment of door arm length, force controls or limit controls.
- Any repair to or adjustment of the garage door (including springs and hardware).
- Any repair to or buckling of the garage floor.

IMPORTANT SAFETY INSTRUCTIONS



To reduce the risk of severe injury or death to persons:

1. READ AND FOLLOW ALL INSTRUCTIONS.
2. Do not permit children either to operate or to play with the opener. Keep a remote control in a location inaccessible to children.
3. Operate opener only when the door is in full view and free from any obstruction. Keep the door in sight until it is completely closed. **NO ONE SHOULD CROSS THE PATH OF THE MOVING DOOR.**
4. Check safety reversal system monthly. See page 26. The garage door **MUST** reverse on contact with a one-inch object (or a 2x4 board laid flat) placed on the floor. If an adjustment is made to either the force or the limit of travel, both adjustments may be needed and the safety reversal system must be checked. *Failure to properly adjust the opener may result in severe injury or death.*
5. If possible, use the manual release only when the door is in a closed position. Caution should be taken whenever the disconnect cord is actuated with the door open. *Weak or broken springs may cause the door to fall rapidly, causing injury or death to persons.*
6. **KEEP GARAGE DOORS PROPERLY BALANCED.** See page 3. *An improperly balanced door may not reverse when required and could result in severe injury or death.* Repairs to cables, spring assemblies and other hardware must be made by a professional garage door person.
7. Disconnect the electric power from the garage door opener before making any repairs or removing the covers.
8. **SAVE THESE INSTRUCTIONS.**

Do not exceed 8 complete cycles of door operation per hour in commercial applications.

Care of Your Opener

Limit and Force Adjustment Controls

Limit Controls

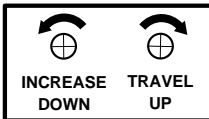

Adjustment Label
(Located on the left side panel)

Force Controls

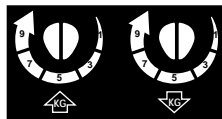

Adjustment Label
(Located on the back panel)

Weather conditions may cause some minor changes in door operation requiring some re-adjustments, particularly during the first year of operation.

Pages 24 and 25 refer to the limit and force adjustments. Only a screwdriver is required. Follow the instructions carefully.

Repeat the safety reverse test (page 26) after any adjustment of limits or force.

The remote control transmitter:

The opener must learn the code of any new remote control. Page 29 explains how to program your garage door opener and how to erase all codes if required. Self service of your receiver and remote controls is not recommended. If service is needed, call the toll-free number listed on the back page.

The transmitter battery:

The green test light will glow and the opener will operate when the remote control is activated, as long as there is adequate battery power.

If the test light is *dim or off*, replace the battery. Also check the test light if transmission range decreases.

The 12V battery should produce power for at least a year.

Dispose of your old battery properly.

Maintenance Schedule

Once a Month

Manually operate door. If it is unbalanced or binding, call for professional garage door service.

Check to be sure door opens and closes fully. Adjust limits and/or force if necessary. (See pages 24 and 25.)

Repeat the safety reverse test. Make any necessary adjustments. (See page 26.)

Twice a Year

Check chain tension. Disconnect trolley first. Adjust if necessary (See page 10).

Once a Year

Oil door rollers, bearings and hinges. The opener does not require additional lubrication. Do not grease the door tracks.

Operation of Your Opener

Activate the opener with any of the following devices:

- **The Remote Control Transmitter.** Hold push button down until the door starts to move.
- **The Door Control.** Hold button down until the door starts to move.
- **The Outside Keylock or Keyless Entry.** (See Accessories.)

When the opener is activated with the Safety Reversing Sensor installed and correctly aligned:

1. If open, the door will close. If closed, the door will open.
2. If closing, the door will reverse.
3. If opening, the door will stop (allowing space for entry and exit of pets and for fresh air).
4. If the door has been stopped in a partially open position, it will close.
5. If obstructed while closing, the door will reverse.
6. If obstructed while opening, the door will stop.
7. The garage door will reverse in the closing cycle when the invisible beam is broken. If fully open, the door will not close when the beam is broken. The sensor has no effect in the opening cycle.

If the sensor is not installed, or is not aligned correctly, the door won't close from any remote control transmitter. You can close the door with the Door Control, the Outside Keylock, or Keyless Entry, however, if you activate them until down travel is complete. If you release them too soon, the door will reverse.

The opener light will *blink for 5 seconds* when the safety reversing sensor causes the door to reverse.

The Opener Light will turn on under the following conditions: When the opener is initially plugged in; when the power is interrupted; when the opener is activated. It will turn off automatically after 4-1/2 minute. Bulb size is 75 watts maximum.

Operation of the Door Control Button

Press to open or close the door.

Press again to *reverse* the door during the closing cycle or to *stop* the door while it's opening.



WARNING

Weak or broken springs could allow an open door to fall (either rapidly or unexpectedly), resulting in serious injury, death or property damage. If possible, use the manual release rope and handle *only* when the door is fully closed.

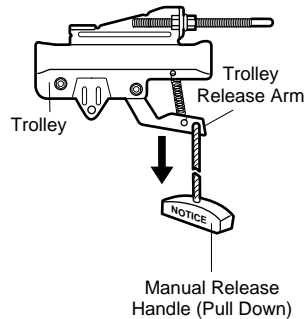

Manual disconnect position

To open the door manually:

The door should be fully closed if possible. Pull down on the red manual release handle and lift the door manually. To reconnect the door to the opener, press the Door Control button.

The lockout feature prevents the trolley from reconnecting automatically. Pull the red manual release handle down and back (toward the opener). The door can then be raised and lowered manually as often as necessary. To disengage the Lockout Feature, pull the manual release handle straight down. The trolley will reconnect on the next UP or DOWN operation.

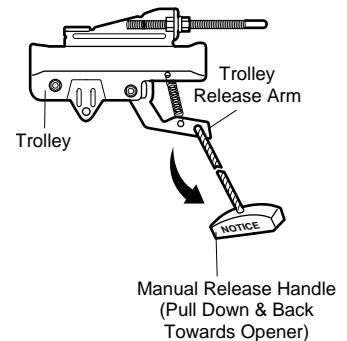

Lockout position

Receiver and Remote Control Programming

NOTICE: To comply with FCC rules, adjustment or modification of this receiver and/or transmitter are prohibited, except for changing the code setting or replacing the transmitter battery. THERE ARE NO OTHER USER SERVICEABLE PARTS.

Your garage door opener receiver and remote control transmitter have been set at the factory to a matching code. The door will open when you press the remote control push button.

Your "Smart" garage door opener will operate with:

- up to four "Smart" remote control transmitters (with green indicator lights),
- a Keyless Entry System, and
- code switch remote controls with red indicator lights.

Below are instructions below for programming your opener to match any additional remotes you may purchase. See available accessories on page 34.

To Add A Remote

1. Press and *hold* the remote push button. See Figure 1.
2. Then press and release the green "Smart" button on the back panel of the opener in Figure 2. The indicator light on the panel will *flash once*.
3. Release the remote push button.

Now the opener will operate when the remote control push button is pressed.

If you release the remote control push button before the indicator light flashes, the opener will not accept the code.

To Erase All Remote Control Codes

- Press and hold the green "Smart" button on the opener panel until the indicator light turns off (about 6 seconds). **All the codes the opener has learned will be erased.**
- To reprogram, repeat Steps 1 – 3 for each remote control in use.

Code programming instructions are also located on the opener panel.



WARNING

Children operating or playing with a garage door opener can injure themselves or others. **The garage door could close and cause serious injury or death. Do not allow children to operate the door control or remote control transmitter(s).**

A moving garage door could injure or kill someone under it. Activate the opener only when you can see the door clearly, it is free of obstructions, and is properly adjusted.

Figure 1

Single-Function Remote Control

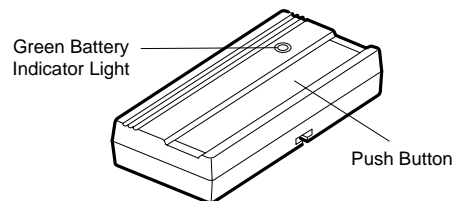
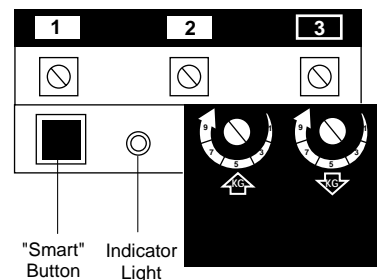

Figure 2

Garage Door Opener (With "Smart" Button)



END PANEL

Having a Problem?

Situation

Probable Cause & Solution

The opener doesn't operate from either the door control or the remote control:

1. Does the opener have electric power? Plug a lamp into the outlet. If it doesn't light, check the fuse box or the circuit breaker. (Some outlets are controlled by a wall switch.)
 2. Have you disabled all door locks? Review installation instruction warnings on Page 10.
 3. Is there a build-up of ice or snow under the door? The door may be frozen to the ground. Remove any restriction.
 4. The garage door spring may be broken. Have it replaced.
 5. Repeated operation may have tripped the overload protector in the motor. Wait 15 minutes. Try again.
-

Opener operates from the remote control but not from the door control:

1. Is the door control button lit? If not, Remove the bell wire from the opener terminal screws. Short the red and white terminals by touching both terminals at the same time with a piece of wire. If the opener runs, check for a faulty wire connection at the door control, a short under the staples, or a broken wire.
 2. Are the wiring connections correct? Review Step 6, page 16.
-

The door operates from the door control, but not from the remote control:

1. Does the battery test light glow when the remote control push button is pressed? If not, replace the battery.
 2. Program the receiver to match the remote control code.
 3. Repeat the receiver programming procedure with all remote controls.
-

The remote control has short range:

1. Check the battery test light. If the light is dim, change the battery.
2. Change the location of the remote control in your car.
3. Check to be sure the antenna on the back panel of opener extends fully downward.
4. Some installations may have shorter range due to a metal door, foil backed insulation, or metal garage siding.

Install Antenna Kit, Part No. 41A3504, to increase range.

Opener noise is disturbing in living quarters of home:

If operational noise is a problem because of proximity of the opener to the living quarters, the Vibration Isolator Kit 41A3263 can be installed. This kit was designed to minimize vibration to the house and is easy to install.

The garage door opens and closes by itself:

1. Be sure that all remote control push buttons and battery indicator lights are off.
 2. Remove the bell wire from the door control terminals and operate from the remote control only. If this solves the problem, the door control is faulty (replace), or there is an intermittent short on the wire between the door control and the opener.
-

The door doesn't open completely:

1. If the door has been working properly but now doesn't open all the way, increase the *up force*. See page 25.
2. Is something obstructing the door? Remove the obstruction or repair the door.
3. If door opens at least 5 feet, the travel limits may need to be increased. One turn equals 2 inches of travel. See page 24.

Repeat the safety reverse test after the adjustment is complete.

The door stops but doesn't close completely:

Review the travel limits adjustment procedures on page 24.

Repeat the safety reverse test after any adjustment of door arm length, close force or down limit.

Having a Problem? (continued)

| Situation | Probable Cause & Solution |
|--|--|
| The door opens but won't close: | <ol style="list-style-type: none">1. If the opener lights blink, check the safety reversing sensor. See page 21.2. If the opener lights do not blink and it is a new installation, check the down force. See Adjustment Step 2, page 25. For an existing installation, see below. <p>Repeat the safety reverse test after the adjustment is complete.</p> |
| The door reverses for no apparent reason and opener light doesn't blink: | <ol style="list-style-type: none">1. Is something obstructing the door? Pull the manual release handle. Operate the door manually. If it is unbalanced or binding, call for professional garage door service.2. Clear any ice or snow from the garage floor area where the door closes.3. Review the force adjustment procedures on page 25. <p>Repeat the safety reverse test after the adjustment is complete.</p> <ol style="list-style-type: none">4. If door reverses in the <i>fully closed</i> position, decrease the travel limits (page 24). <p>Repeat safety reverse test after the adjustment is complete. The need for occasional adjustment of the force and limit settings is normal. Weather conditions in particular can affect door travel.</p> |
| The door reverses for no apparent reason and opener light blinks for 5 seconds after reversing: | Check the safety reversing sensor. Remove any obstruction or align the receiving eye. See page 21. |
| The opener light | <p>. . . doesn't turn on:</p> <p>Replace the light bulb (75 watts maximum). Use a <i>standard neck</i> garage door opener bulb if regular bulb burns out.</p> <p>. . . doesn't turn off:</p> <p>There may be a defective ground at the ceiling or wall receptacle. The unit must be grounded.</p> |
| The opener strains or maximum force is needed to operate door: | The door may be out of balance or the springs are broken. Close the door and use the manual release handle to disconnect the trolley. Open and close the door manually. A properly balanced door will stay in any point of travel while being supported entirely by its springs. If it does not, disconnect the opener and call for professional garage door service. |
| The opener motor hums briefly, then won't work: | <ol style="list-style-type: none">1. The garage door springs are broken. See above.2. If the problem occurs on the first operation of the opener, door may be locked. <i>Disable the door lock</i>. If the chain was removed and re-installed, the motor may be out of phase. Remove the chain; cycle the motor to the down position. Observe the drive sprocket. When it turns in a clockwise direction and stops in the down position, reinstall the chain. <p>Repeat the safety reverse test after the adjustment is complete.</p> |
| The opener won't operate due to power failure: | <ol style="list-style-type: none">1. Use the manual release rope and handle to disconnect the trolley. The door can be opened and closed manually. When power is restored, press the door control button and trolley will automatically reconnect (unless trolley is in lockout position.) See page 28.2. The Outside Quick Release accessory (for use on garages with no service door) disconnects the trolley from outside the garage in case of power failure. |
| The chain droops or sags: | It is normal for the chain to droop slightly in the closed door position. Use the manual release rope and handle to disconnect the trolley. If the chain returns to the normal height when the trolley is disengaged and the door reverses on a one-inch board (or a 2x4 laid flat), no adjustments are needed. (See page 10.) |

Repair Parts

Rail Assembly Parts

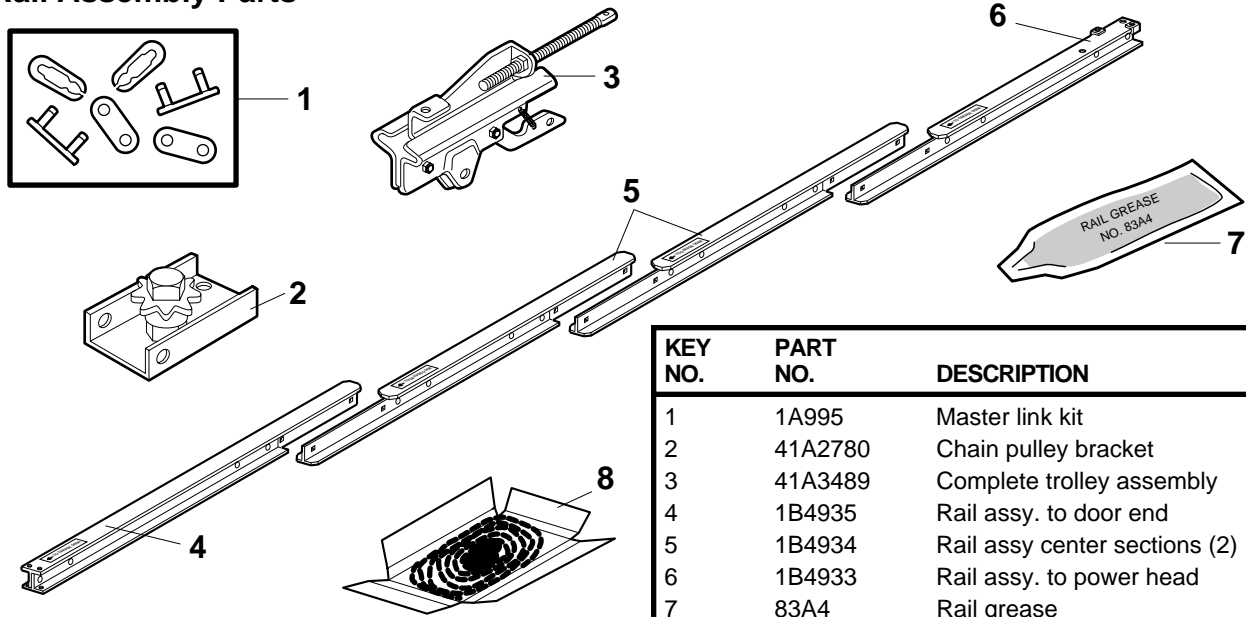

| KEY NO. | PART NO. | DESCRIPTION |
|---------|----------|--|
| 1 | 1A995 | Master link kit |
| 2 | 41A2780 | Chain pulley bracket |
| 3 | 41A3489 | Complete trolley assembly |
| 4 | 1B4935 | Rail assy. to door end |
| 5 | 1B4934 | Rail assy center sections (2) |
| 6 | 1B4933 | Rail assy. to power head |
| 7 | 83A4 | Rail grease |
| 8 | 41A4554 | Chain |
| 9 | 41A4937 | Rail assy hardware kit (Includes hardware listed on page 5). |

Installation Parts

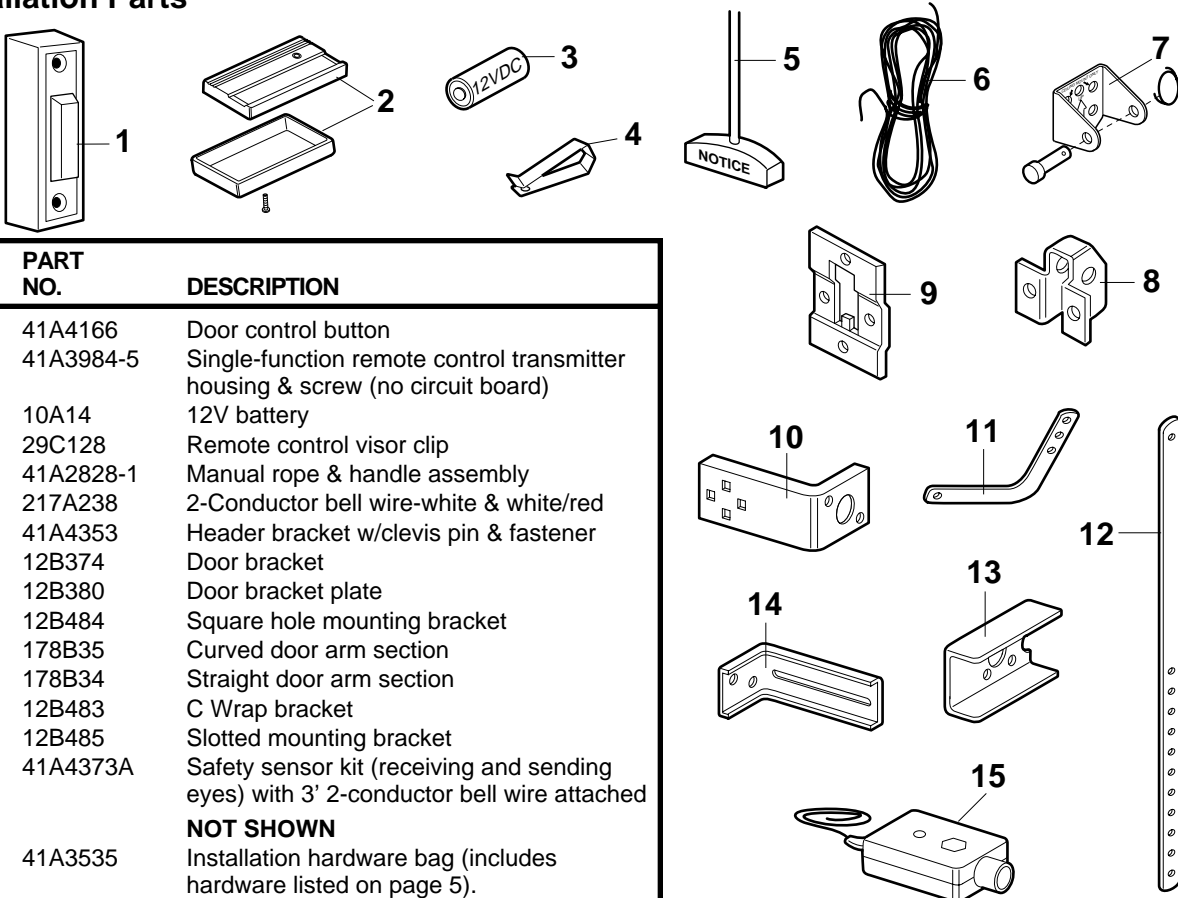

| KEY NO. | PART NO. | DESCRIPTION |
|---------|-----------|---|
| 1 | 41A4166 | Door control button |
| 2 | 41A3984-5 | Single-function remote control transmitter housing & screw (no circuit board) |
| 3 | 10A14 | 12V battery |
| 4 | 29C128 | Remote control visor clip |
| 5 | 41A2828-1 | Manual rope & handle assembly |
| 6 | 217A238 | 2-Conductor bell wire-white & white/red |
| 7 | 41A4353 | Header bracket w/clevis pin & fastener |
| 8 | 12B374 | Door bracket |
| 9 | 12B380 | Door bracket plate |
| 10 | 12B484 | Square hole mounting bracket |
| 11 | 178B35 | Curved door arm section |
| 12 | 178B34 | Straight door arm section |
| 13 | 12B483 | C Wrap bracket |
| 14 | 12B485 | Slotted mounting bracket |
| 15 | 41A4373A | Safety sensor kit (receiving and sending eyes) with 3' 2-conductor bell wire attached |
| | | NOT SHOWN |
| | 41A3535 | Installation hardware bag (includes hardware listed on page 5). |
| | 41A4116 | Safety sensor hardware |
| | 114A2007 | Owner's manual |



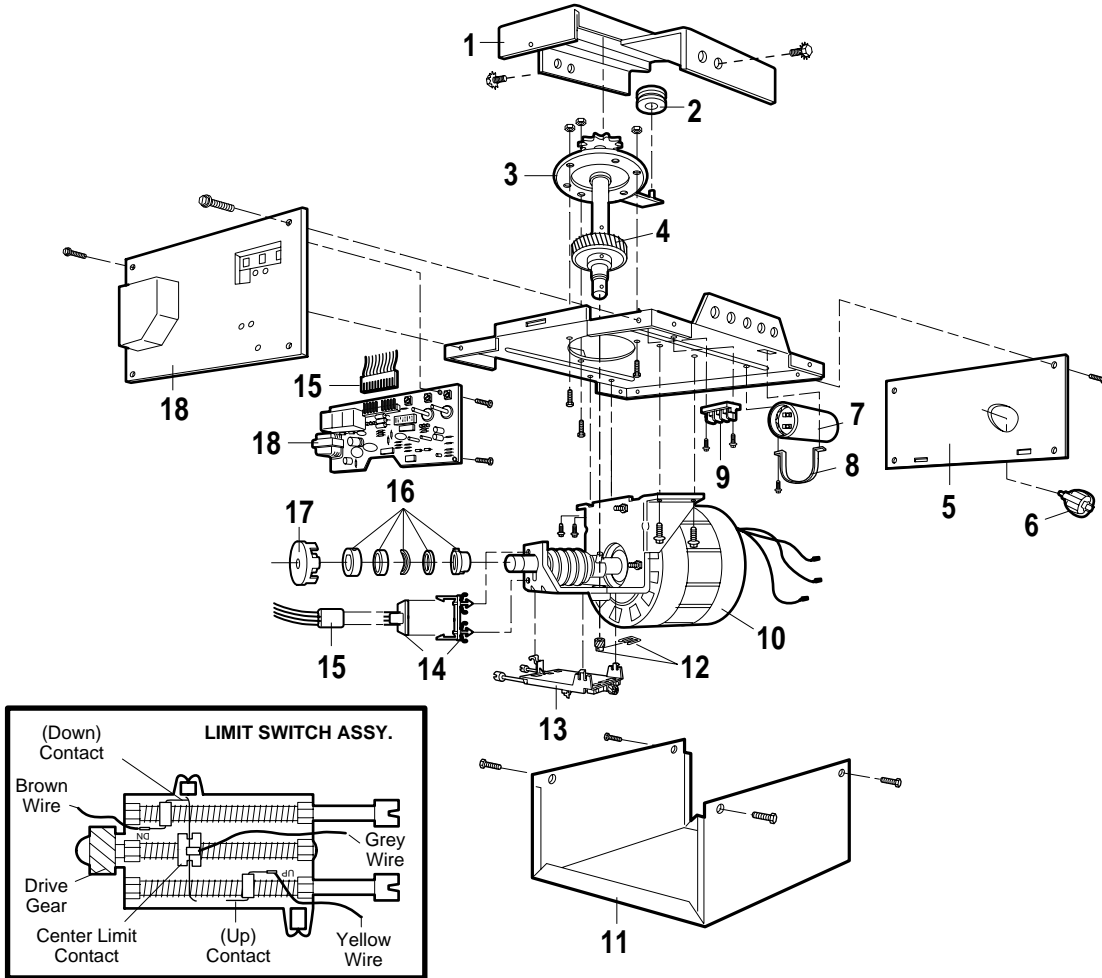

Repair Parts

Opener Assembly Parts

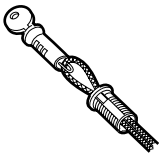
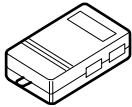
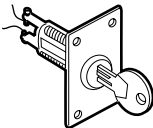
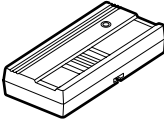
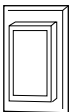
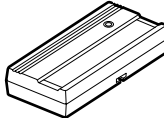

| KEY NO. | PART NO. | DESCRIPTION | KEY NO. | PART NO. | DESCRIPTION |
|---------|----------|--|--|----------|--------------------------------------|
| 1 | 41D4478 | Rail support bracket assembly kit | 10 | 41D4509 | Replacement motor & bracket assembly |
| 2 | 144B18 | Pulley (Chain) | Complete with: Motor, worm, bracket, bearing assembly 11 41A4936 Cover 12 41A2818 Helical gear & retainer w/grease 13 41D3452 Limit switch assembly 14 41C4398A RPM sensor assembly 15 41C4246 Wire harness assembly w/plug 16 41A2826 Shaft bearing kit 17 41A2822A Interruptor cup assembly 18 41A4252-7D Receiver logic board assembly Complete with: Logic board, end panel with all labels NOT SHOWN 41A2825 Opener assembly hardware kit (includes screws not designated by a number in illustration). | | |
| 3 | 41C4470 | Gear and sprocket assy. Complete with: Spring washer Thrust washer Retaining washer Bearing plate Roll pins (2) Drive gear and worm gear Helical gear w/retainer and grease Sprocket shaft plate with screws | | | |
| 4 | 41A2817 | Drive/worm gear kit w/grease Roll pins (2) | | | |
| 5 | 143D100 | Front end panel | | | |
| 6 | 175B88M | Light socket | | | |
| 7 | 30B432 | Capacitor | | | |
| 8 | 12A461 | Capacitor bracket | | | |
| 9 | 41A3150 | Terminal block with screws | | | |

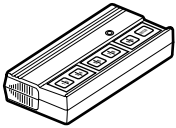
Accessories Available for your Opener

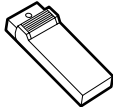
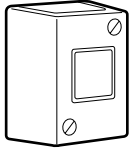
| | | | |
|---|--|---|--|
| <p>7702CB</p>  | <p>Outside Quick Release: <i>Required</i> for a garage with NO access door.</p> | <p>856CB</p>  | <p>Multi-Function Mini Remote Control: With key ring & Velcro fastening strip.</p> |
| <p>760CB</p>  | <p>Outside Keylock: Opens the garage door automatically from outside when remote control is not handy.</p> | <p>853CB</p>  | <p>Multi-Function Standard Size Remote Control: Includes visor clip.</p> |
| <p>872CB</p>  | <p>Wire-In Light Control: Controls interior or exterior lights. Wires into the electrical box like a dimmer switch.</p> | <p>850CB</p>  | <p>Single-Function Standard Size Remote Control: Includes visor clip.</p> |
| <p>874CB</p>  | <p>Plug-In Light Control: Controls interior lights. Plugs into a wall receptacle.</p> | <p>959CB</p>  | <p>Security Remote Control Enables homeowner to operate garage door opener by entering 2, 3, 4, or 5 digit code from backlit keyboard. Includes visor clip.</p> |
| <p>945CB</p>  | <p>Multi-Function Door Control Panel: Provides a Lock Feature which prevents operation of garage door opener from portable remotes and a Light Feature for constant light.</p> | <p>740CB</p>  | <p>Keyless Entry: Enables homeowner to operate garage door opener from outside by entering code on specially designed keypad.</p> |
| <p>180C139</p>  | <p>NEMA 1 Push Button: Heavy Duty Door Control Push Button (one button).</p> | <p>41A3504 Coaxial Cable</p> | <p>Antenna Extender Kit: If the metal environment in which the operator has been installed causes short radio control range, install Antenna Extender Kit, Part No. 41A3504.</p> |

Index

| | |
|--|--|
| Access Door/Outside Quick Release Accessory | 4, 34 |
| Chain Tension | 4, 10, 31 |
| Electrical Safety Warnings | 2, 10, 18, 27 |
| Garage Door | |
| Testing for balance, binding and sticking..... | 3, 25, 27 |
| Determining high point of travel: | 11 |
| Disabling existing locks..... | 3, 10 |
| Force Controls | |
| Adjustment procedures..... | 25 |
| Problems that might require force adjustments | 30, 31 |
| Safety warnings | 25, 27 |
| Door hardware | 3, 10, 11, 16, 27, 28 |
| Maintenance Instruction Label..... | 10, 16 |
| Reinforcement requirements | 4, 22 |
| Removing all ropes..... | 3, 10 |
| Possible door damage | 3, 14, 22 |
| Travel Limits | |
| Adjustment procedures..... | 24 |
| Problems that might require limit adjustments..... | 30, 31 |
| Safety warnings | 24, 27 |
| Manual Release Rope & Handle | |
| Lockout feature | 28 |
| Manual disconnect..... | 28, 31 |
| Safety warnings | 10, 17, 27, 28 |
| Opener Terminals | |
| Door control connections..... | 16 |
| Safety reversing sensor connections..... | 21 |
| Operational Noise | |
| Sprocket noise | 10 |
| Vibration noise (isolator kit) | 30 |
| Protector System® | 19, 26 |
| Receiver and Remote Controls | |
| Programming the receiver | 29 |
| Erasing all codes | 29 |
| Safety warning..... | 29 |
| Problems with remote control operation | 30 |
| Safety Reverse Test Procedure | 26 |
| Testing required..... | 10, 26, 30, 31 |
| Safety Reverse System Problems | |
| Securing header bracket to wall | 11 |
| Adjusting travel limits | 24 |
| Applying excessive force on the door..... | 25 |
| Buckling or uneven floor | 4 |
| Safety Warnings | 2, 3, 8, 9, 10, 11, 14, 15, 16, 17, 18, 19, 22, 24, 25, 26, 27, 28, 29 |
| User Instruction Label for garage wall | 10, 16 |

CHAMBERLAIN SERVICE IS ON CALL

OUR LARGE SERVICE ORGANIZATION
SPANS AMERICA

INSTALLATION AND SERVICE INFORMATION IS AS
NEAR AS YOUR TELEPHONE SIX DAYS A WEEK.
SIMPLY DIAL OUR TOLL FREE NUMBER:

1-800-528-9131

HOURS: (Mountain Std. Time)
6:00 A.M. TO 6:00 P.M. - Monday through Friday
7:00 A.M. TO 3:00 P.M. - Saturday
Closed Sunday

For professional installation, parts and service,
contact your local CHAMBERLAIN dealer. Look for him
in the Yellow Pages, or call our Service number for a list
of dealers in your area.

HOW TO ORDER REPAIR PARTS

Selling prices will be furnished on request or parts will
be shipped at prevailing prices and you will be billed
accordingly.

WHEN ORDERING REPAIR PARTS, ALWAYS GIVE
THE FOLLOWING INFORMATION:

- PART NUMBER
- PART NAME
- MODEL NUMBER

ADDRESS ORDERS TO:
THE CHAMBERLAIN GROUP, INC.
Parts and Service Department
2301 N. Forbes Boulevard, Suite 104
Tucson, Arizona 85745

SERVICE INFORMATION
TOLL FREE NUMBER:

1-800-528-9131

CHAMBERLAIN GARAGE DOOR OPENER ONE-YEAR LIMITED WARRANTY

The Chamberlain Group, Inc. ("Seller") warrants to the first retail purchaser of this product that it is free from defect in materials and/or workmanship for a period of one year from the date of purchase. **The proper operation of this product is dependent on your compliance with the Owner's Manual instructions regarding installation, operation, maintenance and testing. Failure to comply strictly with those instructions will void this warranty in its entirety. Please note that the safety reverse system, in order to operate properly with your garage door, must be adjusted and periodically tested in accordance with the Owner's Manual.**

If, during the limited warranty period, it appears as though this product contains a defect which is covered by this limited warranty, **call our toll free service number, before dismantling this product, at 1-800-528-9131.** Then send this product, pre-paid and insured, to our service center for warranty repair. You will be advised of shipping instructions when you call the toll free service number. Please include a brief description of the problem and a dated proof-of-purchase receipt with any product that is returned for warranty repair.

Products returned to Seller for warranty repair, which upon receipt by Seller are confirmed to be defective and covered by this limited warranty, will be repaired or replaced (at Seller's sole option) at no cost to you and returned pre-paid. Defective parts will be repaired or replaced with new or factory-rebuilt parts at Seller's sole option.

THIS LIMITED WARRANTY IS IN LIEU OF ANY OTHER WARRANTIES, EXPRESS OR IMPLIED, INCLUDING ANY IMPLIED WARRANTY OF MERCHANTABILITY OR FITNESS FOR A PARTICULAR PURPOSE, OR OTHERWISE, AND OF ANY OTHER OBLIGATIONS OR LIABILITY ON SELLEER'S PART. THIS LIMITED WARRANTY DOES NOT COVER NON-DEFECT DAMAGE, DAMAGE CAUSED BY IMPROPER INSTALLATION, OPERATION OR CARE (INCLUDING, BUT NOT LIMITED TO ABUSE, MISUSE, FAILURE TO PROVIDE REASONABLE AND NECESSARY MAINTENANCE, OR ANY ALTERNATIONS TO THIS PRODUCT), LABOR CHARGES FOR DISMANTLING OR REINSTALLING A REPAIRED OR REPLACED UNIT, OR REPLACEMENT BATTERIES.

UNDER NO CIRCUMSTANCES SHALL SELLER BE LIABLE FOR CONSEQUENTIAL, INCIDENTAL OR SPECIAL DAMAGES ARISING IN CONNECTION WITH THE USE, OR INABILITY TO USE, THIS PRODUCT. IN NO EVENT SHALL SELLER'S LIABILITY FOR BREACH OF WARRANTY, BREACH OF CONTRACT, NEGLIGENCE OR STRICT LIABILITY EXCEED THE COST OF THE PRODUCT COVERED HEREBY. NO PERSON IS AUTHORIZED TO ASSUME FOR US ANY OTHER LIABILITY IN CONNECTION WITH THE SALE OF THIS PRODUCT.

Some states do not allow the exclusion or limitation of consequential, incidental or special damages, so the above limitation or exclusion may not apply to you. This limited warranty gives you specific legal rights, and you may also have other rights which vary from state to state.

LIMITED WARRANTY ON MOTOR

Model CSO: The motor is warranted to be free from any defect in materials and/or workmanship for a period of 12 full months (1 year) from the date of purchase.