

CHAMBERLAIN®

# LiftMaster®

## PROFESSIONAL

### Model 371LM Security+® Single Button Remote Control OWNER'S MANUAL

Only for use with 315 MHz Security+® garage door openers and universal receivers that have a purple "learn" button.

**Instructions are Described and Illustrated Below**

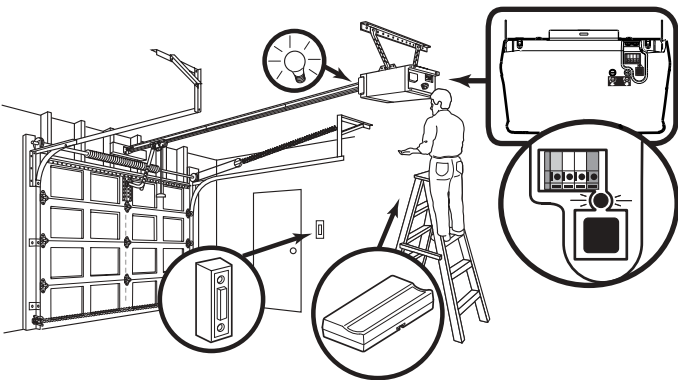

1. Press and release the "learn" button on the motor unit. The learn indicator light will glow steadily for 30 seconds.
2. Within 30 seconds, press and hold the button on the hand-held remote.
3. Release the button when the motor unit light blinks. It has learned the code. If light bulbs are not installed, two clicks will be heard.

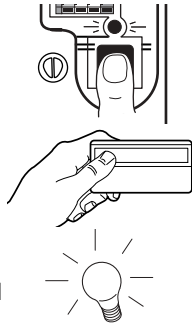

#### To Erase All Codes From Motor Unit Memory

To deactivate any unwanted remote, first erase all codes:

Press and hold the "learn" button on motor unit until the learn indicator light goes out (approximately 6 seconds). All previous codes are now erased. Reprogram each remote or keyless entry you wish to use.



Replacement Parts	
3V2032 Lithium battery	.....10A20
Visor clip	.....29B137
Owner's Manual - Spanish	.....114A3092SP

**⚠ WARNING**

To prevent possible SERIOUS INJURY or DEATH from a moving gate or garage door:

- ALWAYS keep remote controls out of reach of children. NEVER permit children to operate, or play with remote control transmitters.
- Activate gate or door ONLY when it can be seen clearly, is properly adjusted, and there are no obstructions to door travel.
- ALWAYS keep gate or garage door in sight until completely closed. NEVER permit anyone to cross path of moving gate or door.

#### The Remote Control Batteries

**⚠ WARNING**

To prevent possible SERIOUS INJURY or DEATH:

- NEVER allow small children near batteries.
- If battery is swallowed, immediately notify doctor.

The lithium batteries should produce power for up to 5 years. To replace, pry open case with visor clip or screwdriver, as shown. Insert batteries *positive side up (+)*. Dispose of old batteries properly.

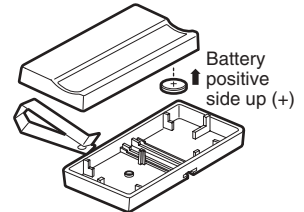

**NOTICE:** To comply with FCC and or Industry Canada (IC) rules, adjustment or modifications of this receiver and/or transmitter are prohibited, except for changing the code setting or replacing the battery. THERE ARE NO OTHER USER SERVICEABLE PARTS.  
Tested to Comply with FCC Standards FOR HOME OR OFFICE USE. Operation is subject to the following two conditions: (1) this device may not cause harmful interference, and (2) this device must accept any interference received, including interference that may cause undesired operation.

**FOR SERVICE DIAL OUR TOLL FREE NUMBER:  
US: 1-800-528-2817  
CANADA: 1-800-654-4736**